

THE INFORMATION CONTAINED HEREIN IS CONSIDERED "PROPRIETARY" TO BEL FUSE INC. AND SHALL NOT BE COPIED, REPRODUCED OR DISCLOSED WITHOUT THE WRITTEN APPROVAL OF BEL FUSE INC.

LED 1 POLARITY			LED 2 POLARITY		
PIN 17	PIN 18	COLOR	PIN 19	PIN 20	COLOR
-	+	YELLOW	+	-	ORANGE
			-	+	GREEN

RoHS



ELECTRICAL CHARACTERISTICS @ 25°C

URNS RATIO

TP1 1CT : 1CT ±2%
 TP2 1CT : 1CT ±2%

□CL @ 100kHz/100mVRMS

FOR CHANNEL 1 AND CHANNEL 2

11mA DC BIAS 350µH MIN.

Compliant to IEEE 802.3at specification

INS. LOSS

0.1MHz TO 1MHz -1.1 dB MAX
 1MHz TO 65MHz -0.8 dB MAX
 65MHz TO 100MHz -1.2 dB MAX

RET. LOSS (MIN)

0.5MHz-40MHz -18 dB
 40MHz-100MHz -12+20LOG(f/80MHz) dB

CM TO CM REJ

100kHz - 100MHz -30 dB MIN

CM TO DM REJ

100kHz - 100MHz -35 dB MIN

HIPOT (Isolation Voltage): 2250 VDC

100% OF PRODUCTION TESTED TO COMPLY WITH
 IEEE 802.3 ISOLATION REQUIREMENTS.

BALANCED DC LINE CURRENT 720 mA MAX. @ 57 VDC CONTINUOUS

1.2 A MAX. @ 57 VDC FOR 200 MILLISECONDS

LED 1

VF (FORWARD VOLTAGE) IF=20mA YELLOW 2.1V TYP.
 λD (DOMINANT WAVELENGTH) IF=20mA YELLOW 590nm TYP.

LED 2

VF (FORWARD VOLTAGE) IF=20mA GREEN 2.2V TYP.
 ORANGE 2.0V TYP.
 λD (DOMINANT WAVELENGTH) IF=20mA GREEN 570nm TYP.
 ORANGE 610nm TYP.

OPERATING TEMPERATURE: -40°C TO 85°C

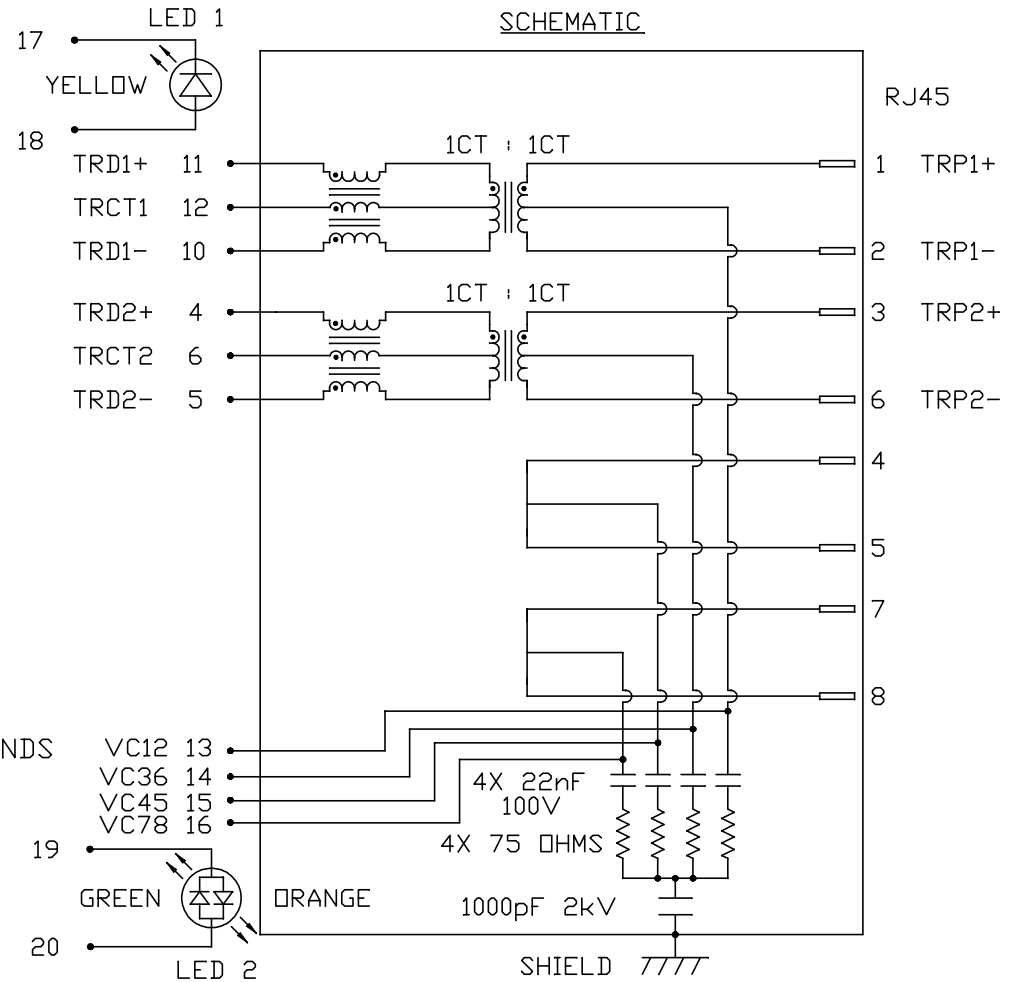

ORIGINATED BY
 CHOW WANCHUNG
 DATE 2016-08-11
 DRAWN BY
 SKY YOU
 DATE 2016-08-11

TITLE
 10/100 MagJack®
 (PoEp, Extended Temperature)
 0826-1X1T-GJ-F
 PATENTED

PART NO. / DRAWING NO.
 08261X1TGJ-F
 FILE NAME
 08261X1TGJ-F_D.DWG

STANDARD DIM.
 TOL. IN INCH
 X
 XX
 XXX
 [] METRIC DIM.
 AS REF.
 UNIT : INCH [mm]
 SCALE : N/A
 SIZE : A4



THE INFORMATION CONTAINED HEREIN IS CONSIDERED "PROPRIETARY" TO BEL FUSE INC. AND SHALL NOT BE COPIED, REPRODUCED OR DISCLOSED WITHOUT THE WRITTEN APPROVAL OF BEL FUSE INC.

MECHANICAL SPECIFICATION

RoHS

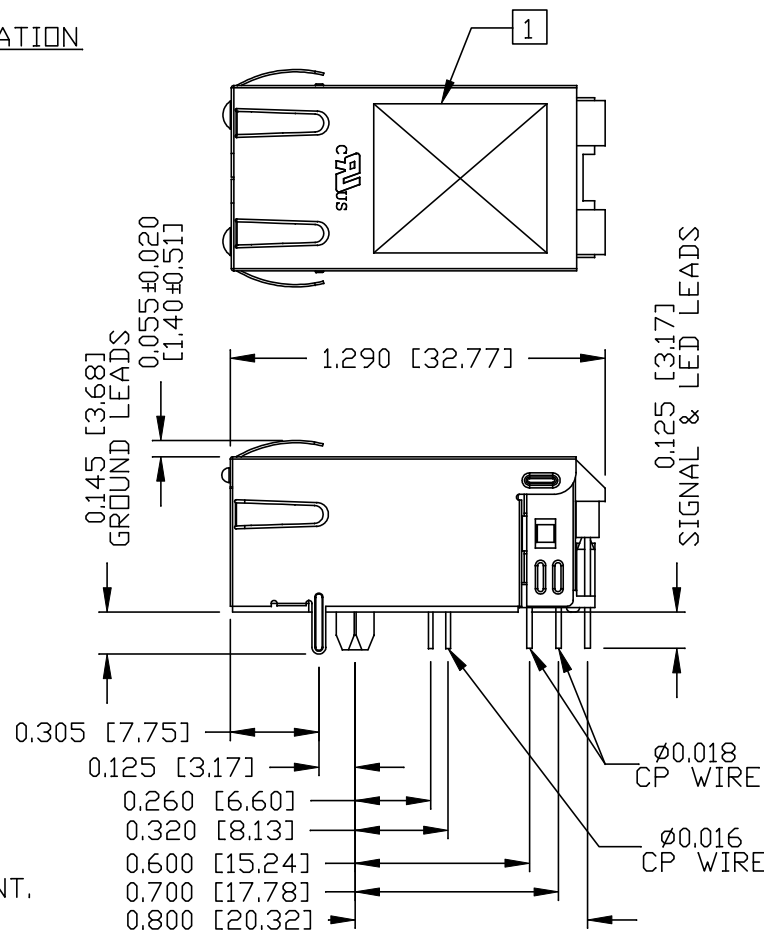
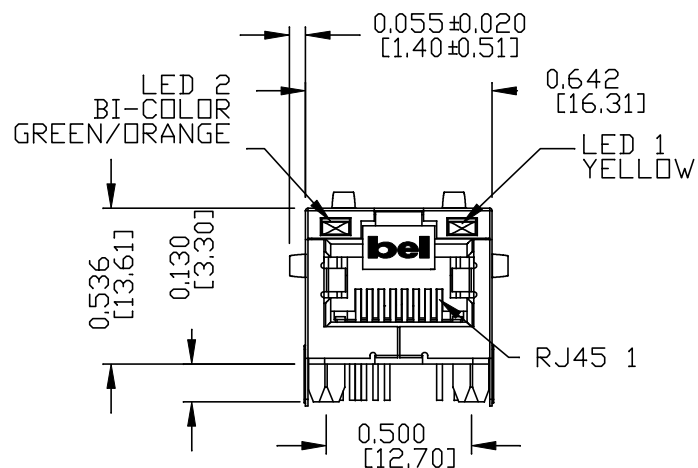

NOTES:

- PLASTIC HOUSING: THERMOPLASTIC PA, BLACK
FLAMMABILITY RATING UL 94V-0
- CONTACTS: 50 MICRO-INCH HARD GOLD PLATING OR EQUIVALENT.
30 MICRO-INCH MIN NICKEL UNDERPLATE.
- OUTPUT PINS: TIN-COATED COPPER WIRE, DIA 0.016 AND DIA 0.018 INCH.
100 MICRO-INCH MIN MATTE TIN. PINS ARE SOLDER DIPPED.
- METAL SHIELD: NICKEL PLATED ON COPPER ALLOY.
(ALL GROUND LEADS ARE SOLDER DIPPED)

1. MARK PART WITH MFG LOGO, MFG NAME, PART NUMBER, DATE CODE AND PATENTED.

UL US UL RECOGNIZED - FILE #E196366 AND E169987.

- 2. THE PRODUCT IS RoHS COMPLIANT.
- 3. JACK CAVITY CONFORMS TO FCC RULES AND REGULATIONS.
- 4. THE PRODUCT IS PATENTED, THE PATENT NUMBER IS U.S. PAT. 7,123,117.
- 5. THE PART IS RECOMMENDED FOR WAVE SOLDERING. THE SUGGESTED PEAK WAVE SOLDERING CONDITION IS 260°C MAX AND 10 SECONDS MAX.

ORIGINATED BY
ANTON LIAO
DATE 2016-08-11
DRAWN BY
JESSE LI
DATE 2016-08-11

TITLE
10/100 MagJack®
(PoEp, Extended Temperature)
0826-1X1T-GJ-F
PATENTED

PART NO. / DRAWING NO.
08261X1TGJ-F
FILE NAME
08261X1TGJ-F_D.DWG

STANDARD DIM. TOL. IN INCH	[] METRIC DIM. AS REF.
.X	UNIT : INCH [mm]
.XX	SCALE : N/A
.XXX ±0.010	SIZE : A4

REV. : D PAGE : 3



THE INFORMATION CONTAINED HEREIN IS CONSIDERED "PROPRIETARY" TO BEL FUSE INC. AND SHALL NOT BE COPIED, REPRODUCED OR DISCLOSED WITHOUT THE WRITTEN APPROVAL OF BEL FUSE INC.

RoHS



RECOMMENDED PCB FOOTPRINT
COMPONENT SIDE VIEW

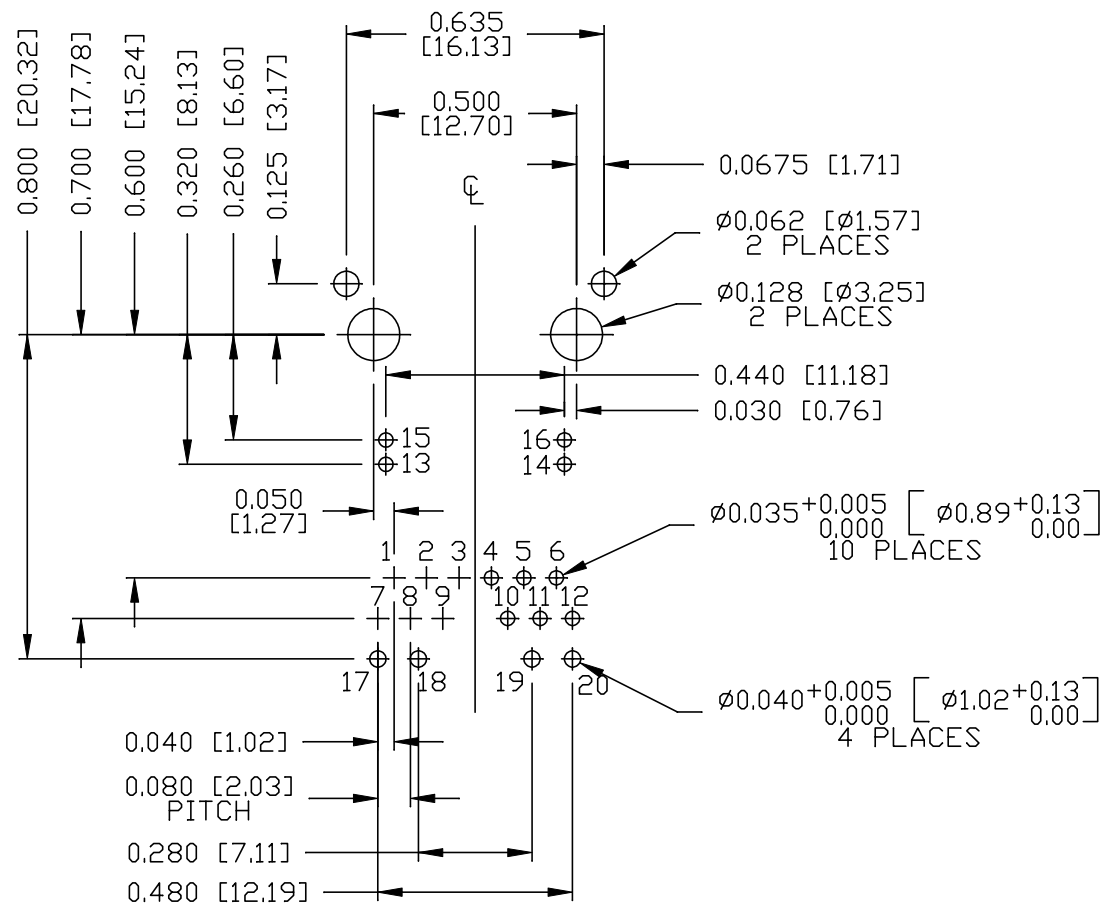
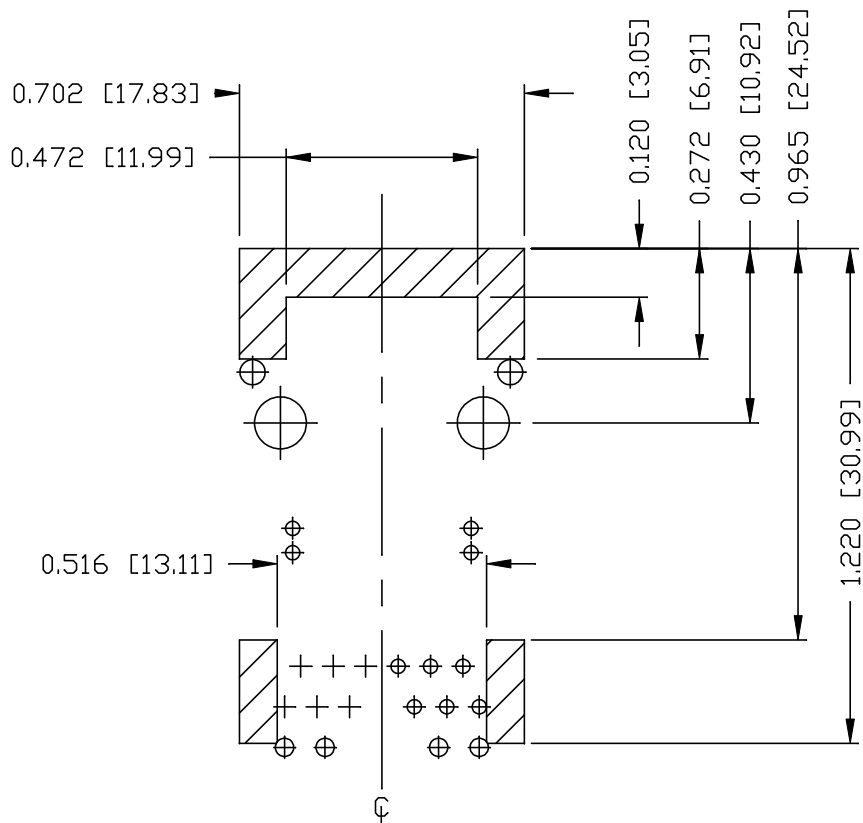

NOTES

THE SHADED AREA ON THE CUSTOMER BOARD ARE RECOMMENDED TO BE CLEAR OFF ANY VIA HOLE OR COMPONENT PAD.

REV. : D PAGE : 4

ORIGINATED BY ANTON LIAO DATE 2016-08-11	TITLE 10/100 MagJack® (PoEp, Extended Temperature)	PART NO. / DRAWING NO. 08261X1TGJ-F	STANDARD DIM. TOL. IN INCH	[] METRIC DIM. AS REF.
			.X	UNIT : INCH [mm]
DRAWN BY JESSE LI DATE 2016-08-11	0826-1X1T-GJ-F PATENTED	FILE NAME 08261X1TGJ-F_D.DWG	.XX	SCALE : N/A
			.XXX	±0.004
			SIZE : A4	



THE INFORMATION CONTAINED HEREIN IS CONSIDERED "PROPRIETARY" TO BEL FUSE INC. AND SHALL NOT BE COPIED, REPRODUCED OR DISCLOSED WITHOUT THE WRITTEN APPROVAL OF BEL FUSE INC.

RoHS



SUGGESTED PANEL OPENING

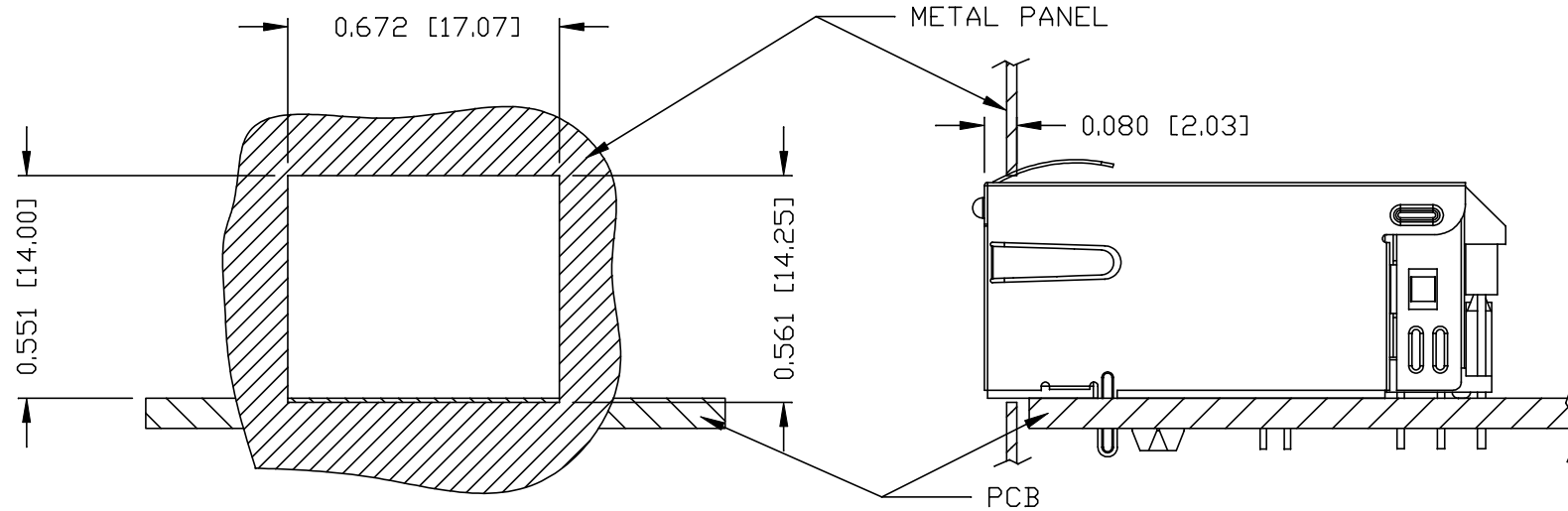

NOTE:

THE DISTANCE OF PANEL INSIDE SURFACE RELATIVE TO FRONT SURFACE OF PART IS ONLY A SUGGESTION. IN CASE THIS DISTANCE IS DIFFERENT, THE REQUIRED PANEL OPENING DIMENSIONS CHANGE ACCORDINGLY.

PACKING INFORMATION

PACKING TRAY : 0200-9999-F6 (TOP)
0200-9999-F7 (BOTTOM)

PACKING QUANTITY : 40 PCS FINISHED GOODS PER TRAY
10 TRAYS (400 PCS FINISHED GOODS) PER CARTON BOX

NOTE : CARDBOARDS ARE PLACED BETWEEN LAYERS OF PACKING TRAY INSIDE CARTON BOX
(INCLUDE THE UPPERMOST AND LOWERMOST TRAY)

REV. : D	PAGE : 5
----------	----------

ORIGINATED BY ANTON LIAO DATE 2016-08-11 DRAWN BY JESSE LI DATE 2016-08-11	TITLE 10/100 MagJack® (PoEp, Extended Temperature) 0826-1X1T-GJ-F PATENTED	PART NO. / DRAWING NO. 08261X1TGJ-F FILE NAME 08261X1TGJ-F_D.DWG	STANDARD DIM. TOL. IN INCH		<input type="checkbox"/> METRIC DIM. AS REF.
			.X		UNIT : INCH [mm]
			.XX		SCALE : N/A
			.XXX	±0.004	<input checked="" type="checkbox"/> <input type="checkbox"/> <input type="checkbox"/> SIZE : A4

