

UNCONTROLLED DOCUMENT

SC:1

PART NUMBER

REV.

LCM-S01602DSR35480

A

UNDER REVISION

REV.	E.C.N. NUMBER AND REVISION COMMENTS	DATE
A	E.C.N. #11524.	08.12.08

CHARACTER DETAIL

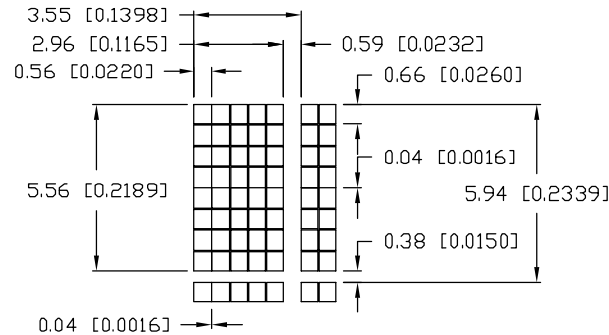

CAUTION: STATIC SENSITIVE DEVICE
FOLLOW PROPER E.S.D. HANDLING PROCEDURES
WHEN WORKING WITH THIS PART.

NOTES:

1. HEADER SIDE WITH 0.635mm DIAMETER PIN TO BE
INSERTED INTO PCB.

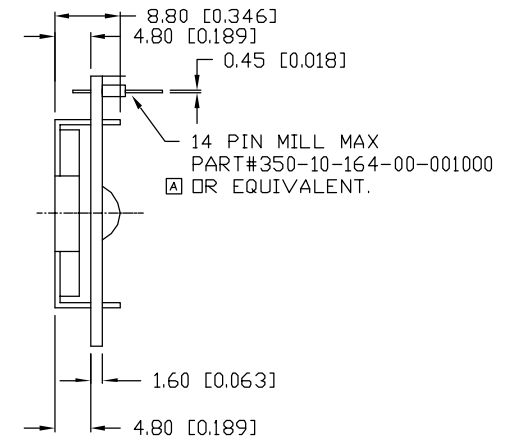
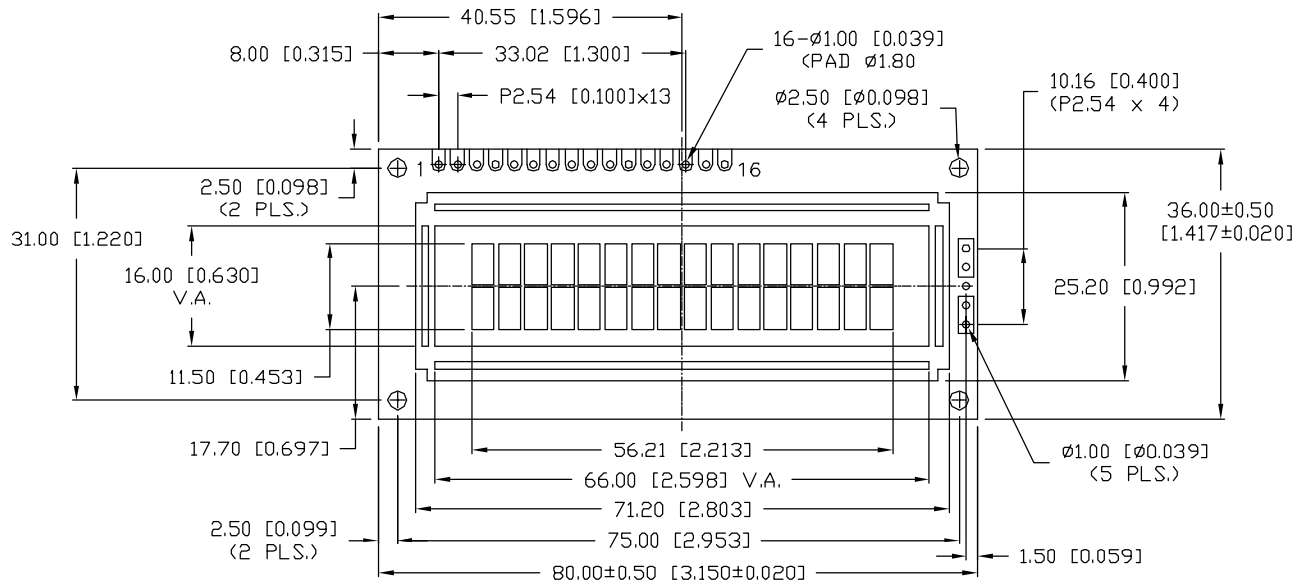

UNCONTROLLED DOCUMENT

*UNLESS OTHERWISE SPECIFIED TOLERANCES PER DECIMAL PRECISION ARE: X=±1 (±0.039), X.X=±0.5 (±0.020), X.XX=±0.25 (±0.010), X.XXX=±0.127 (±0.005). LEAD SIZE=±0.05 (±0.002), LEAD LENGTH=±0.75 (±0.030). MIN= +DECIMAL PRECISION -0.00 MAX= +0.00 -DECIMAL PRECISION

REV.	PART NUMBER
A	LCM-S01602DSR35480

CONFIDENTIAL INFORMATION
THE INFORMATION CONTAINED IN THIS DOCUMENT IS THE PROPERTY OF LUMEX INC. EXCEPT AS SPECIFICALLY AUTHORIZED IN WRITING BY LUMEX INC., THE HOLDER OF THIS DOCUMENT SHALL KEEP ALL INFORMATION CONTAINED HEREIN CONFIDENTIAL AND SHALL PROTECT SAME IN WHOLE OR IN PART FROM DISCLOSURE AND DISSEMINATION TO ALL THIRD PARTIES.



290 E. HELEN ROAD
PALATINE, IL 60067-6976
PHONE: +1.847.359.2790
US WEB: www.lumex.com
TW WEB: www.lumex.com.tw

STN, REFLECTIVE, MILL MAX HEADER, 6:00 VIEW,
5.56mm CHARACTER HEIGHT, 5 x 8 DOT MATRIX,
16 x 2 LCD MODULE, 1/16 DUTY, 1/5 BIAS.

RELIABILITY NOTE
OUR MANY YEARS OF EXPERIENCE DATA ACCUMULATION INDICATE THAT SOLDER HEAT IS A MAJOR CAUSE OF EARLY AND FUTURE FAILURE. PLEASE PAY ATTENTION TO YOUR SOLDERING PROCESS.

DRAWN BY: JD	CHECKED BY:	APPROVED BY:	DATE: 09.26.06
			PAGE: 1 OF 2
			SCALE: N/A

UNCONTROLLED DOCUMENT

SC:1

PART NUMBER

LCM-S01602DSR35480

REV.

A

UNDER REVISION

REV. E.C.N. NUMBER AND REVISION COMMENTS

DATE

SEE ON PAGE ONE.

PIN CONFIGURATION			
PIN NO.	SYMBOL	LEVEL	FUNCTION
1	V _{SS}	-	POWER SUPPLY GND (0V) 5V FOR LCD DRIVE
2	V _{DD}	-	
3	V _O	-	
4	RS	H/L	REGISTER SELECT SIGNAL H: DATA INPUT L: INSTRUCTION INPUT
5	R/W	H/L	H: DATA READ (MODULE-->MPU) L: DATA WRITE (MODULE<--MPU)
6	E	H,H->L	ENABLE
7~14	DB0~DB7	H/L	DATA BUS-SOFTWARE SELECTABLE 4 OR 8 BIT MODE.
15			-
16			-

V_{DD}-V_O: LCD DRIVING VOLTAGE

VR: 10KΩ - 20KΩ

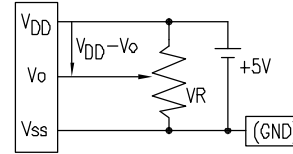

BLOCK DIAGRAM 16 x 2, 1/16 DUTY, 1/5 BIAS

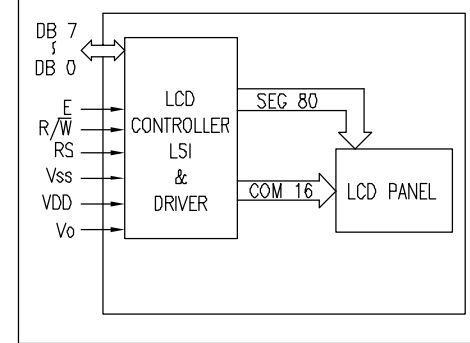

ELECTRICAL CHARACTERISTICS		V _{DD} =4.7V to 5.3V, T _A =25°C				
ITEM	SYMBOL	CONDITION	STANDARD VALUE			UNIT
			MIN.	TYP.	MAX.	
SUPPLY VOLTAGE FOR LOGIC	V _{DD} -V _{SS}	-	-	5.0	-	V
SUPPLY CURRENT FOR LOGIC	I _{DD}	V _{DD} =5V	-	2.0	3.0	mA
INPUT VOLTAGE	HIGH	V _{IH}	-	2.2	-	V _{DD} V
	LOW	V _{IL}	-	0	-	0.6 V
OUTPUT VOLTAGE	HIGH	V _{OH}	-	2.4	-	V
	LOW	V _{OL}	-	-	0.4	V

ABSOLUTE MAXIMUM RATINGS

ITEM	SYMBOL	TEST CONDITION	STANDARD VALUE		UNIT
			MIN	MAX	
SUPPLY VOLTAGE FOR LOGIC	V _{DD} -V _{SS}	T _a =25°C	4.7	5.3	V
SUPPLY VOLTAGE FOR LCD DRIVE	V _{DD} -V _O	-	4.2@50°C	4.8@0°C	V
INPUT VOLTAGE	V _I	T _a =25°C	V _{SS}	V _{DD}	V
OPERATING TEMPERATURE	T _{opr}	LCM-S	0	50	°C
		LCM-H	-20	70	°C
STORAGE TEMPERATURE	T _{stg}	LCM-S	-20	70	°C
		LCM-H	-30	85	°C

UNCONTROLLED DOCUMENT

*UNLESS OTHERWISE SPECIFIED TOLERANCES PER DECIMAL PRECISION ARE: X=±1 (±0.039), X.X=±0.5 (±0.020), X.XX=±0.25 (±0.010), X.XXX=±0.127 (±0.005). LEAD SIZE=±0.05 (±0.002), LEAD LENGTH=±0.75 (±0.030). MIN.= +DECIMAL PRECISION MAX.= +0.00 -DECIMAL PRECISION

REV. PART NUMBER
A LCM-S01602DSR35480

CONFIDENTIAL INFORMATION
THE INFORMATION CONTAINED IN THIS DOCUMENT IS THE PROPERTY OF LUMEX INC. EXCEPT AS SPECIFICALLY AUTHORIZED IN WRITING BY LUMEX INC., THE HOLDER OF THIS DOCUMENT SHALL KEEP ALL INFORMATION CONTAINED HEREIN CONFIDENTIAL AND SHALL PROTECT SAME IN WHOLE OR IN PART FROM DISCLOSURE AND DISSEMINATION TO ALL THIRD PARTIES.



290 E. HELEN ROAD
PALATINE, IL 60067-6976
PHONE: +1.847.359.2790
US WEB: www.lumex.com
TW WEB: www.lumex.com.tw

STN, REFLECTIVE, MILL MAX HEADER, 6:00 VIEW,
5.56mm CHARACTER HEIGHT, 5 x 8 DOT MATRIX,
16 x 2 LCD MODULE, 1/16 DUTY, 1/5 BIAS.

RELIABILITY NOTE
OUR MANY YEARS OF EXPERIENCE DATA ACCUMULATION INDICATE THAT SOLDER HEAT IS A MAJOR CAUSE OF EARLY AND FUTURE FAILURE. PLEASE PAY ATTENTION TO YOUR SOLDERING PROCESS.

DRAWN BY: CHECKED BY: APPROVED BY: DATE: 09.26.06
JD PAGE: 2 OF 2
SCALE: N/A