

THIS DRAWING IS UNPUBLISHED. RELEASED FOR PUBLICATION
 © COPYRIGHT - By - ALL RIGHTS RESERVED.

REVISIONS					
P	LTR	DESCRIPTION	DATE	DWN	APVD
B4		RELEASE PER ECR-19-006455	26APR2019	JH	PKS

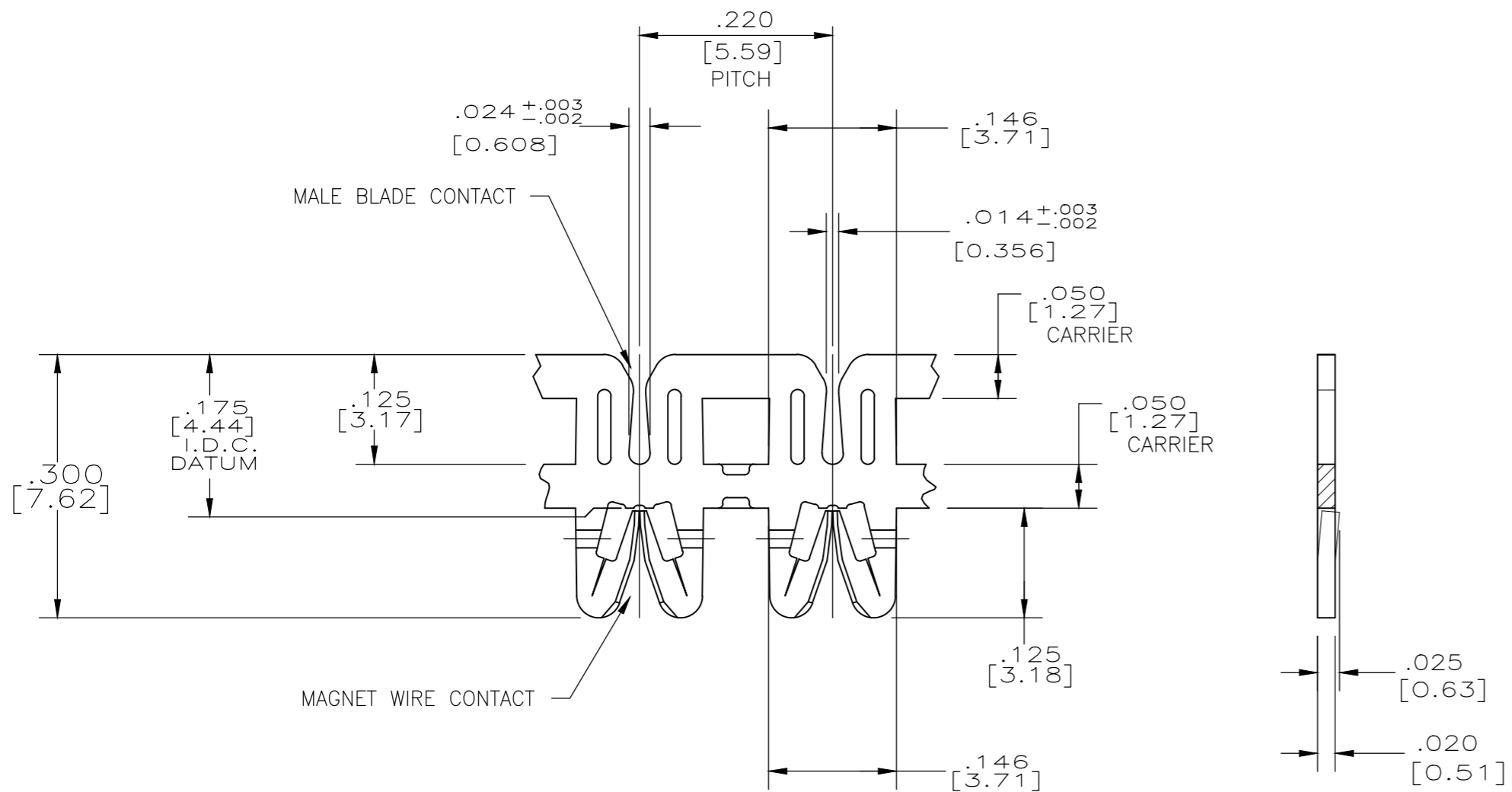

- SPECIFICATIONS:
MAGNET WIRE #18 - #34 AWG, .006"(0.16MM)-.040"(1.02MM) DIA COPPER. OTHER SIZES MAY BE ACCOMMODATED, CONSULT TYCO ELECTRONICS FOR APPROVAL. MALE BLADE .020" (0.5mm) THICK BRASS
- POCKET RECOMMENDATION: #1601426
- TERMINAL APPLICATION TO COMPLY WITH TYCO ELECTRONICS SPECIFICATION 114-13166 FIGURE 11.
- PRELIMINARY - NOT FOR PRODUCTION
- TWO (2) TERMINALS SHOWN FOR ILLUSTRATION PURPOSES ONLY.
- PRE-PRODUCTION - FASR REQUIRED.

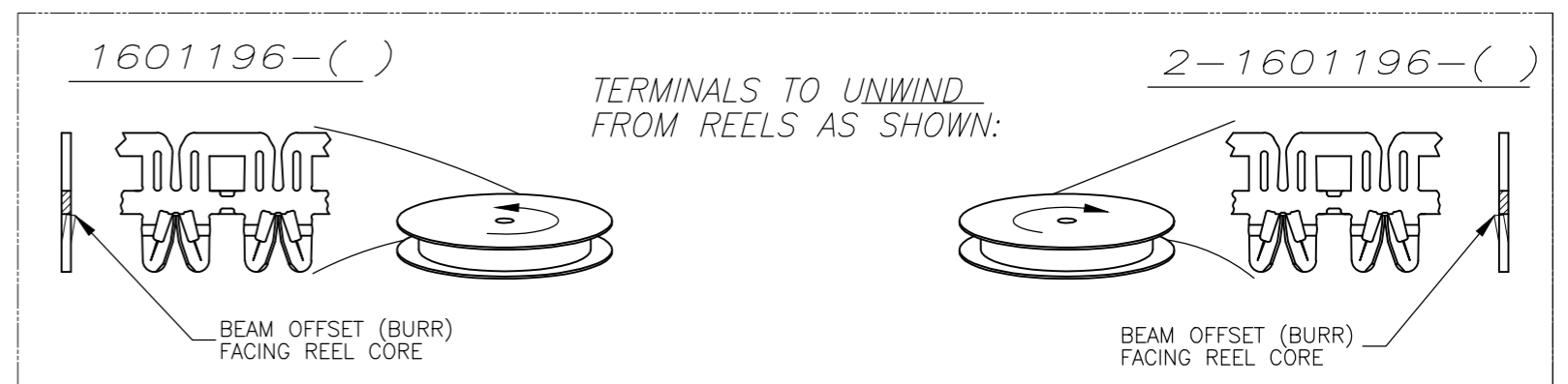
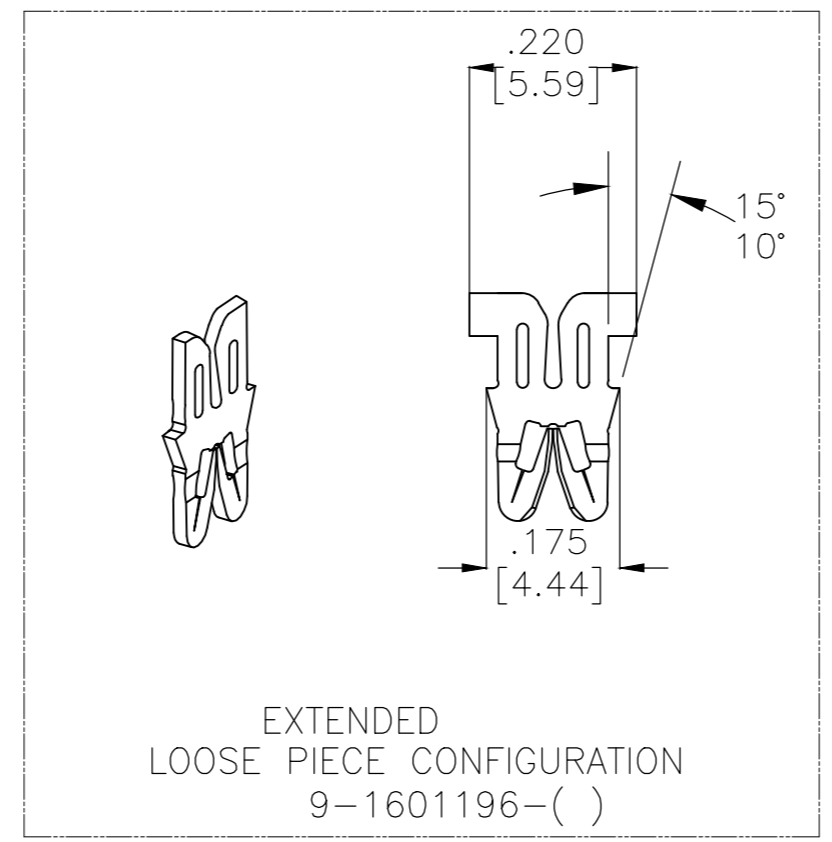
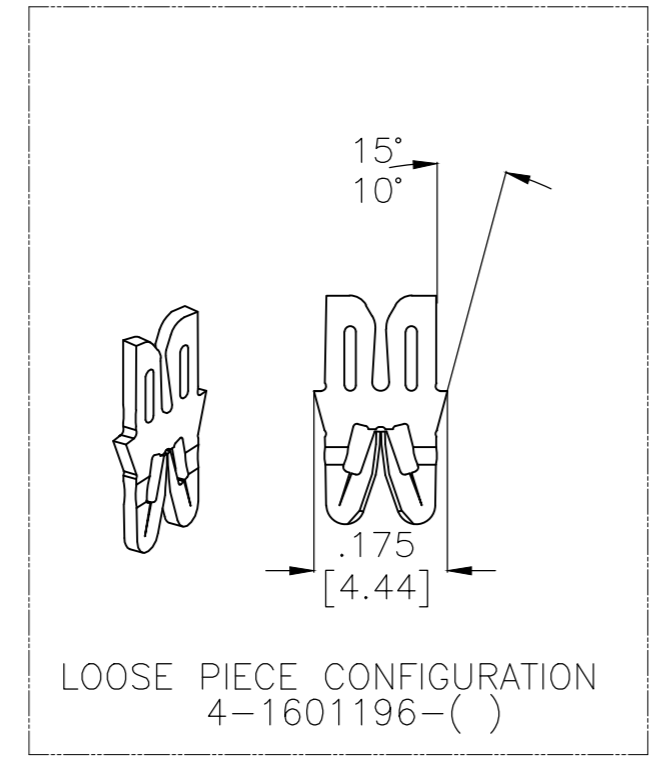
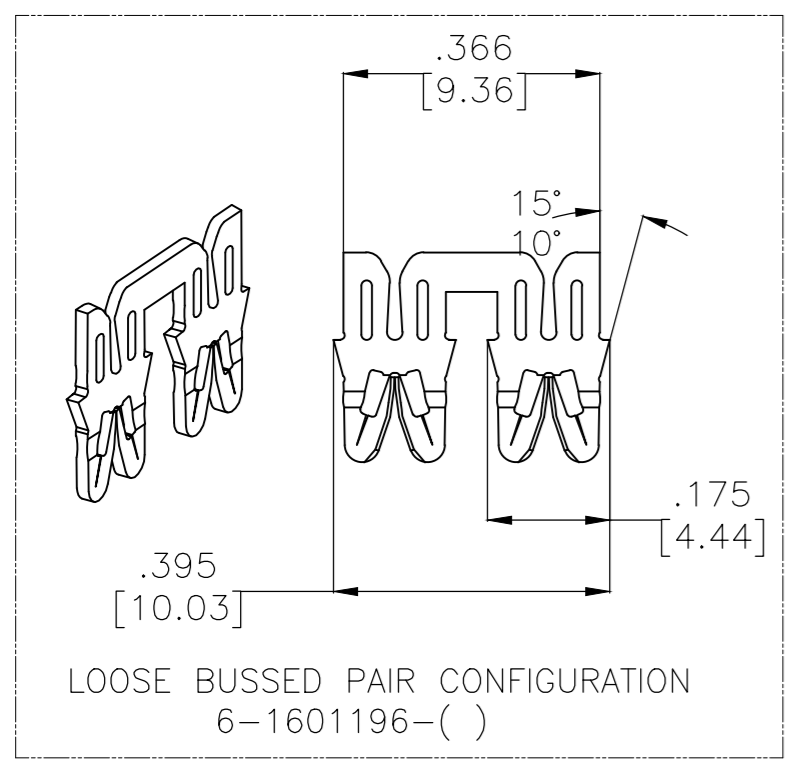
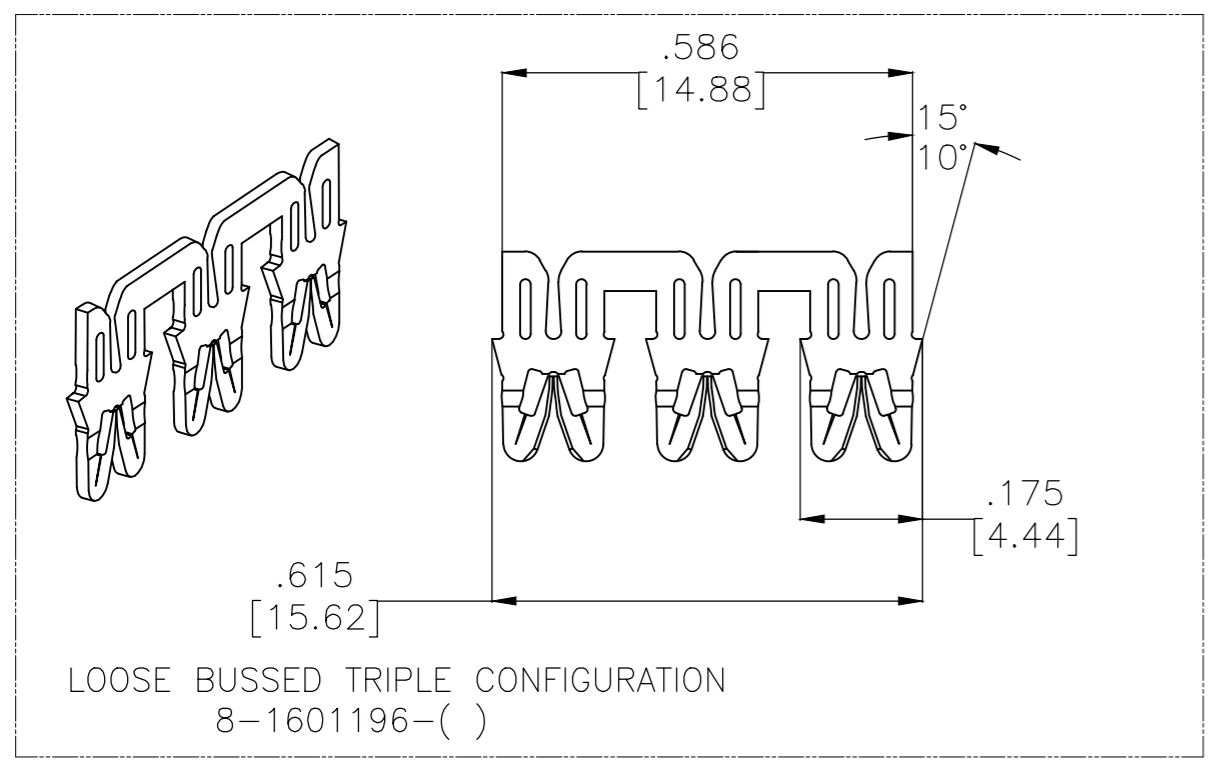

REEL	FINISH	PART NUMBER
N/A	POST TIN OVER NICKEL	6-1601196-3
N/A	POST TIN OVER NICKEL	4-1601196-3
N/A	UNPLATED	9-1601196-1
N/A	UNPLATED	8-1601196-1
N/A	UNPLATED	6-1601196-1
CORRUGATED REEL	UNPLATED	2-1601196-1
PLASTIC REEL	POST TIN OVER NICKEL	1601196-3
CORRUGATED REEL	POST TIN OVER NICKEL	1601196-2
CORRUGATED REEL	UNPLATED	1601196-1

THIS DRAWING IS A CONTROLLED DOCUMENT.

DWN MICHAEL S. FEHER 25MAY2004
 CHK GENE JACONO 25MAY2004
 APVD GENE JACONO 25MAY2004

TE Connectivity

STANDARD RANGE HIGH CARRIER WIRE TO BLADE SIAMEZE TERMINAL

108-2085

1601196

WEIGHT 0.10
 SCALE 1:1
 SHEET 1 OF 1
 REV B4