

## OPA838 1-mA, 300-MHz Gain Bandwidth, Voltage-Feedback Op Amp

### 1 Features

- Gain Bandwidth Product: 300 MHz
- Very-Low (Trimmed) Supply Current: 950  $\mu\text{A}$
- Bandwidth: 90 MHz ( $A_V = 6 \text{ V/V}$ )
- High Full-Power Bandwidth: 45 MHz, 4  $V_{PP}$
- Negative Rail Input, Rail-to-Rail Output
- Single-Supply Operating Range: 2.7 V to 5.4 V
- 25°C Input Offset:  $\pm 125 \mu\text{V}$  (Maximum)
- Input Offset Voltage Drift:  $< \pm 1.6 \mu\text{V}/^\circ\text{C}$  (Maximum)
- Input Voltage Noise:  $1.8 \text{ nV}/\sqrt{\text{Hz}}$  ( $> 200 \text{ Hz}$ )
- Input Current Noise:  $1 \text{ pA}/\sqrt{\text{Hz}}$  ( $> 2000 \text{ Hz}$ )
- $< 1\text{-}\mu\text{A}$  Shutdown Current for Power Savings

### 2 Applications

- Low-Power Transimpedance Amplifiers
- Low-Noise High-Gain Stages
- 12-Bit to 16-Bit Low-Power SAR ADC Drivers
- High-Gain Active Filter Designs
- Ultrasonic Flow Meters

### 3 Description

The OPA838 uncompensated voltage feedback operational amplifier provides a high 300-MHz gain bandwidth product with  $1.8\text{-nV}/\sqrt{\text{Hz}}$  input noise voltage, requiring only a trimmed 0.95-mA supply current. These features combine to provide an extremely power-efficient solution for photodiode transimpedance designs and high-voltage gain stages, which require the lowest input voltage noise in signal receiver applications.

Operating at the minimum recommended noninverting gain of 6 V/V results in a 90-MHz,  $-3\text{-dB}$  bandwidth. Extremely low input noise and offset voltage make the OPA838 particularly suitable for high gains. Even at a DC-coupled gain of 1000 V/V, a 300-kHz signal bandwidth is available with a maximum output offset voltage of  $\pm 125 \text{ mV}$ .

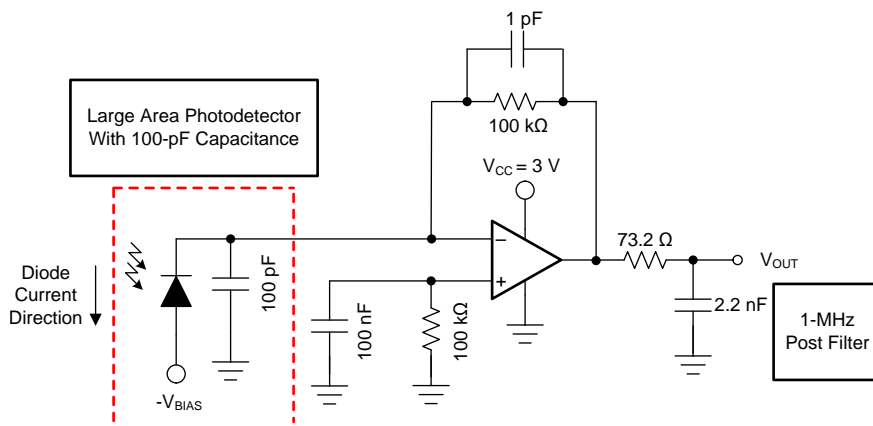
The single-channel OPA838 is available in 6-pin SOT-23 and SC70 packages with a power shutdown feature and a 5-pin SC70 package.

#### Device Information<sup>(1)</sup>

PART NUMBER	PACKAGE	BODY SIZE (NOM)
OPA838	SOT-23 (6)	2.90 mm $\times$ 1.60 mm
	SC70 (5)	2.00 mm $\times$ 1.25 mm
	SC70 (6)	2.00 mm $\times$ 1.25 mm

(1) For all available packages, see the package option addendum at the end of the data sheet.

#### Single 3-V Supply, $< 3\text{-mW}$ Photodiode Amplifier With $< 1.1\text{-pA}/\sqrt{\text{Hz}}$ Total Input-Referred Current Noise and $100\text{-k}\Omega$ Gain With Overall 1-MHz SSBW



## Table of Contents

<b>1 Features</b> .....	1	8.2 Functional Block Diagram .....	20
<b>2 Applications</b> .....	1	8.3 Feature Description .....	20
<b>3 Description</b> .....	1	8.4 Device Functional Modes .....	24
<b>4 Revision History</b> .....	2	8.5 Power Shutdown Operation .....	27
<b>5 Device Comparison Table</b> .....	4	<b>9 Application and Implementation</b> .....	28
<b>6 Pin Configuration and Functions</b> .....	4	9.1 Application Information .....	28
<b>7 Specifications</b> .....	5	<b>10 Power Supply Recommendations</b> .....	36
7.1 Absolute Maximum Ratings .....	5	<b>11 Layout</b> .....	37
7.2 ESD Ratings .....	5	11.1 Layout Guidelines .....	37
7.3 Recommended Operating Conditions .....	5	11.2 Layout Example .....	37
7.4 Thermal Information .....	5	<b>12 Device and Documentation Support</b> .....	38
7.5 Electrical Characteristics: $V_S = 5\text{ V}$ .....	6	12.1 Device Support .....	38
7.6 Electrical Characteristics: $V_S = 3\text{ V}$ .....	8	12.2 Documentation Support .....	38
7.7 Typical Characteristics: $V_S = 5\text{ V}$ .....	10	12.3 Trademarks .....	39
7.8 Typical Characteristics: $V_S = 3\text{ V}$ .....	13	12.4 Electrostatic Discharge Caution .....	39
7.9 Typical Characteristics: Over Supply Range .....	16	12.5 Glossary .....	39
<b>8 Detailed Description</b> .....	20	<b>13 Mechanical, Packaging, and Orderable Information</b> .....	39
8.1 Overview .....	20		

## 4 Revision History

NOTE: Page numbers for previous revisions may differ from page numbers in the current version.

Changes from Revision A (February 2018) to Revision B	Page
• Changed $< 5\text{-}\mu\text{A Shutdown Current}$ to $< 1\text{-}\mu\text{A Shutdown Current}$ in <i>Features</i> section .....	1
• Changed value of common-mode and differential-mode input impedance in Electrical Characteristics: $V_S = 5\text{ V}$ and Electrical Characteristics: $V_S = 3\text{ V}$ tables .....	7
• Changed value of power-down quiescent current in Electrical Characteristics: $V_S = 5\text{ V}$ and Electrical Characteristics: $V_S = 3\text{ V}$ tables .....	7
• Changed $5\text{ }\mu\text{A}$ to $1\text{ }\mu\text{A}$ in <i>Overview</i> section .....	20
• Changed standby current from $5\text{ }\mu\text{A}$ to $1\text{ }\mu\text{A}$ in <i>Power-Down Operation</i> section .....	21
• Changed common-mode input capacitance from $1.3\text{ pF}$ to $1\text{ pF}$ in <i>Trade-Offs in Selecting The Feedback Resistor Value</i> section .....	22
• Changed $1 + 6.3 / 1.2 = 6.25\text{ V/V}$ , adding the $1.3\text{-pF}$ device common-mode capacitance to $1 + 6 / 1.2 = 6\text{ V/V}$ , adding the $1\text{-pF}$ device common-mode capacitance in <i>Trade-Offs in Selecting The Feedback Resistor Value</i> section .....	22
• Changed $2\text{ }\mu\text{A}$ to $0.1\text{ }\mu\text{A}$ and $5\text{ }\mu\text{A}$ to $1\text{ }\mu\text{A}$ in last sentence of <i>Power Shutdown Operation</i> section .....	27
• Changed <i>Power Supply Recommendations and Thermal Notes</i> title to <i>Power Supply Recommendations</i> .....	36

Changes from Original (August 2017) to Revision A	Page
• Added OPA837 to the <i>Device Comparison</i> table .....	4
• Changed <i>Device Comparison</i> table note .....	4
• Changed format of pin names in pinout drawings in <i>Pin Configuration and Functions</i> section .....	4
• Added DCK to pinout description in 6-pin SOT-23 and SC70 pinout drawing .....	4
• Changed I/O column header to "TYPE" in <i>Pin Configuration and Functions</i> section .....	4
• Added table note to table to define pin types in <i>Pin Configuration and Functions</i> section .....	4
• Added table note to <i>Absolute Maximum Ratings</i> table .....	5
• Changed bandwidth for 0.1-dB flatness test condition from $V_{OUT} = 2\text{ V}_{PP}$ and $G = 10$ to $V_{OUT} = 200\text{ mV}_{PP}$ and $G = 6$ in the Electrical Characteristics: $V_S = 5\text{ V}$ table .....	6
• Added values for $V_{OH}$ and $V_{OL}$ parameters at $T_A = -40$ to $+125^\circ\text{C}$ in Electrical Characteristics: $V_S = 5\text{ V}$ table .....	7

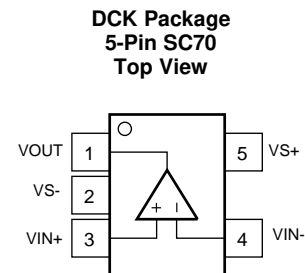
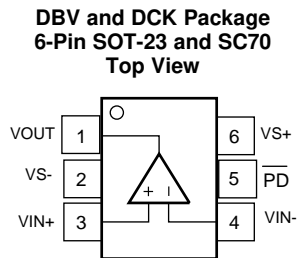
• Changed typical bandwidth for 0.1-dB flatness from 5 MHz to 9 MHz in Electrical Characteristics: $V_S = 3\text{ V}$ table .....	8
• Changed bandwidth for 0.1-dB flatness test conditions from $V_{OUT} = 2\text{ V}_{PP}$ and $G = 10$ to $V_{OUT} = 200\text{ mV}_{PP}$ and $G = 6$ in Electrical Characteristics: $V_S = 3\text{ V}$ table .....	8
• Added values for $V_{OH}$ and $V_{OL}$ parameters at $T_A = -40$ to $+125^\circ\text{C}$ in Electrical Characteristics: $V_S = 3\text{ V}$ table .....	9
• Changed $V_O$ test condition from 20 mV to 200 mV in <a href="#">Figure 5</a> .....	10
• Changed $V_O$ test condition from 20 mV to 200 mV in <a href="#">Figure 6</a> .....	10
• Changed test conditions from $V_{OUT} = 2\text{ V}_{PP}$ , $R_F = 0\ \Omega$ , $G = 1\text{ V/V}$ to $R_F = 1\text{ k}\Omega$ , $R_G = 200\ \Omega$ , $R_L = 2\text{ k}\Omega$ , $G = 6\text{ V/V}$ in <i>Typical Characteristics: <math>V_S = 3\text{ V}</math></i> section .....	13
• Changed $V_O$ test condition from 20 mV to 200 mV in <a href="#">Figure 23</a> .....	13
• Changed $V_O$ test condition from 20 mV to 200 mV in <a href="#">Figure 24</a> .....	13
• Added condition statement to <a href="#">Typical Characteristics: Over Supply Range</a> .....	16
• Changed Y-axis label from "Disable and $V_O$ (Bipolar supplies)" to "Disable and $V_{OUT}$ (Bipolar Supplies, Volts)" in <a href="#">Figure 51</a> .....	17
• Changed Y-axis label from "PD and Output Voltages" to "Disable and $V_{OUT}$ (Bipolar Supplies, Volts)" in <a href="#">Figure 52</a> .....	17
• Deleted 5-V supply and changed the Y-axis label of <a href="#">Figure 57</a> .....	18
• Changed specification load value from 1-k $\Omega$ to 2-k $\Omega$ in <a href="#">Output Voltage Range</a> section.....	21
• Changed first paragraph to correct power down logic in <a href="#">Power-Down Operation</a> section.....	21
• Changed image references in <a href="#">Power-Down Operation</a> section .....	21
• Changed $V_1$ value from 2.5 $\Omega$ to 2.5 V in <a href="#">Figure 64</a> .....	22
• Changed $V_2$ value from 2.5 $\Omega$ to -2.5 V in <a href="#">Figure 64</a> .....	22
• Changed $V_1$ value from 2.5 $\Omega$ to 2.5 V, changed $V_2$ value from 2.5 $\Omega$ to -2.5 V, and changed $R_{OUT}$ to $R_{LOAD}$ in <a href="#">Figure 66</a> .....	23
• Changed $V_{OUT}$ input signal from $\pm 0.035\text{ V}_{OUT}$ to $\pm 0.35\text{ V}_{IN}$ in <a href="#">Figure 68</a> .....	24
• Changed $V_1$ value from 4.5 $\Omega$ to 4.5 V in <a href="#">Figure 70</a> .....	25
• Changed $V_{EE}$ to ground in <a href="#">Figure 70</a> .....	25
• Changed $V_1$ value from 3 $\Omega$ to 3 V in <a href="#">Figure 72</a> .....	26
• Updated <i>Single-Supply Op Amp Design Techniques</i> application report link in <a href="#">Device Functional Modes</a> section .....	27
• Changed "Cs" and "Cf" to " $C_S$ " and " $C_F$ " in <a href="#">Application Information</a> section .....	34
• Updated <i>Transimpedance Considerations for High-Speed Amplifiers</i> application report link in <a href="#">Detailed Design Procedure</a> section.....	35
• Changed EVM guide link in <a href="#">Layout Guidelines</a> section.....	37

## 5 Device Comparison Table<sup>(1)</sup>

PART NUMBER	GBP (MHz)	5-V I <sub>Q</sub> (mA, MAXIMUM 25°C)	INPUT NOISE VOLTAGE (nV/√Hz)	2-V <sub>PP</sub> THD (dBc, 100 kHz)	RAIL-TO-RAIL INPUT/OUTPUT	DUALS
<a href="#">OPA838</a>	300	0.99	1.9	-110	Negative in/out	None
<a href="#">OPA837</a>	50	0.625	4.7	-120	Negative in/out	<a href="#">OPA2837</a>
<a href="#">OPA835</a>	30	0.35	9.3	-100	Negative in/out	<a href="#">OPA2835</a>
<a href="#">OPA836</a>	110	1	4.8	-115	Negative in/out	<a href="#">OPA2836</a>
<a href="#">LMP7717</a>	88	1.4	5.8	—	Negative in/out	<a href="#">LMP7718</a>
<a href="#">OPA830</a>	100	4.7	9.5	-105	Negative in/out	<a href="#">OPA2830</a>
<a href="#">THS4281</a>	38	0.93	12.5	12.5	In/out	None

(1) For a complete selection of TI high-speed amplifiers, visit [www.ti.com](http://www.ti.com)

## 6 Pin Configuration and Functions



### Pin Functions

NAME	PIN		TYPE <sup>(1)</sup>	DESCRIPTION
	SOT-23 and SC70	SC70		
$\overline{\text{PD}}$	5	—	I/O	Amplifier power down. Low = disabled, high = normal operation (pin must be driven).
VIN-	4	4	I/O	Inverting input pin
VIN+	3	3	I/O	Noninverting input pin
VOUT	1	1	I/O	Output pin
VS-	2	2	P	Negative power-supply pin
VS+	6	5	P	Positive power-supply input

(1) I = input, O = output, and P = power.

## 7 Specifications

### 7.1 Absolute Maximum Ratings

over operating free-air temperature range (unless otherwise noted)<sup>(1)</sup>

		MIN	MAX	UNIT
V <sub>S-</sub> to V <sub>S+</sub>	Supply voltage		5.5	V
	Supply turnon, off maximum dV/dT <sup>(2)</sup>		1	V/μs
V <sub>I</sub>	Input voltage	V <sub>S-</sub> – 0.5	V <sub>S+</sub> + 0.5	V
V <sub>ID</sub>	Differential input voltage		±1	V
I <sub>I</sub>	Continuous input current		±10	mA
I <sub>O</sub>	Continuous output current <sup>(3)</sup>		±20	mA
	Continuous power dissipation	See <a href="#">Thermal Information</a>		
T <sub>J</sub>	Maximum junction temperature		150	°C
T <sub>A</sub>	Operating free-air temperature	–40	125	°C
T <sub>stg</sub>	Storage temperature	–65	150	°C

- (1) Stresses beyond those listed under *Absolute Maximum Ratings* may cause permanent damage to the device. These are stress ratings only, which do not imply functional operation of the device at these or any other conditions beyond those indicated under *Recommended Operating Conditions*. Exposure to absolute-maximum-rated conditions for extended periods may affect device reliability.
- (2) Staying below this ± supply turn-on edge rate prevents the edge-triggered ESD absorption device across the supply pins from turning on.
- (3) Long-term continuous output current for electromigration limits.

### 7.2 ESD Ratings

		VALUE	UNIT
V <sub>(ESD)</sub>	Electrostatic discharge	Human body model (HBM), per ANSI/ESDA/JEDEC JS-001 <sup>(1)</sup>	±1500
		Charged-device model (CDM), per JEDEC specification JESD22-C101 <sup>(2)</sup>	±1000

- (1) JEDEC document JEP155 states that 500-V HBM allows safe manufacturing with a standard ESD control process.
- (2) JEDEC document JEP157 states that 250-V CDM allows safe manufacturing with a standard ESD control process.

### 7.3 Recommended Operating Conditions

over operating free-air temperature range (unless otherwise noted)

		MIN	NOM	MAX	UNIT
V <sub>S+</sub>	Single-supply voltage	2.7	5	5.4	V
T <sub>A</sub>	Ambient temperature	–40	25	125	°C

### 7.4 Thermal Information

THERMAL METRIC <sup>(1)</sup>		OPA838			UNIT
		DBV (SOT-23)	DCK (SC70)	DCKS (SC70)	
		6 PINS	5 PINS	6 PINS	
R <sub>θJA</sub>	Junction-to-ambient thermal resistance	194	203	189	°C/W
R <sub>θJCTop</sub>	Junction-to-case (top) thermal resistance	129	152	150	°C/W
R <sub>θJB</sub>	Junction-to-board thermal resistance	39	76	79	°C/W
ψ <sub>JT</sub>	Junction-to-top characterization parameter	26	58	61	°C/W
ψ <sub>JB</sub>	Junction-to-board characterization parameter	39	76	79	°C/W

- (1) For more information about traditional and new thermal metrics, see the [Semiconductor and IC Package Thermal Metrics](#) application report.

### 7.5 Electrical Characteristics: $V_S = 5\text{ V}$

at  $V_{S+} = 5\text{ V}$ ,  $V_{S-} = 0\text{ V}$ ,  $R_F = 1\text{ k}\Omega$ ,  $R_G = 200\ \Omega$ ,  $R_L = 2\text{ k}\Omega$ ,  $G = 6\text{ V/V}$ , input and output referenced to midsupply, and  $T_A \approx 25^\circ\text{C}$ , (unless otherwise noted)

PARAMETER		TEST CONDITIONS	MIN	TYP	MAX	UNIT	TEST LEVEL <sup>(1)</sup>	
<b>AC PERFORMANCE</b>								
SSBW	Small-signal bandwidth	$V_{OUT} = 20\text{ mV}_{PP}$ , $G = 6$ , (peaking < 4 dB)	75	90		MHz	C	
		$V_{OUT} = 20\text{ mV}_{PP}$ , $G = 10$ , $R_F = 1.6\text{ k}\Omega$		50			C	
		$V_{OUT} = 20\text{ mV}_{PP}$ , $G = 100$ , $R_F = 16.9\text{ k}\Omega$		3			C	
GBP	Gain-bandwidth product	$V_{OUT} = 20\text{ mV}_{PP}$ , $G = 100$	240	300		MHz	C	
LSBW	Large-signal bandwidth	$V_{OUT} = 2\text{ V}_{PP}$ , $G = 6$		45		MHz	C	
		Bandwidth for 0.1-dB flatness	$V_{OUT} = 200\text{ mV}_{PP}$ , $G = 6$		10		MHz	C
SR	Slew rate	From LSBW <sup>(2)</sup>	250	350		V/ $\mu\text{s}$	C	
		Overshoot, undershoot	$V_{OUT} = 2\text{-V step}$ , $G = 6$ , input $t_R = 12\text{ ns}$		1%	2%		C
$t_R, t_F$	Rise, fall time	$V_{OUT} = 2\text{-V step}$ , $G = 6$ , $R_L = 2\text{ k}\Omega$ , input $t_R = 12\text{ ns}$		12.5	13	ns	C	
		Settling time to 0.1%	$V_{OUT} = 2\text{-V step}$ , $G = 6$ , input $t_R = 12\text{ ns}$		30		ns	C
		Settling time to 0.01%	$V_{OUT} = 2\text{-V step}$ , $G = 6$ , input $t_R = 12\text{ ns}$		40		ns	C
HD2	Second-order harmonic distortion	$f = 100\text{ kHz}$ , $V_O = 4\text{ V}_{PP}$ , $G = 6$ (see Figure 74)		-110		dBc	C	
HD3	Third-order harmonic distortion	$f = 100\text{ kHz}$ , $V_O = 4\text{ V}_{PP}$ , $G = 6$ (see Figure 74)		-120		dBc	C	
	Input voltage noise	$f > 1\text{ kHz}$		1.8		nV/ $\sqrt{\text{Hz}}$	C	
	Voltage noise 1/f corner frequency			100		Hz	C	
	Input current noise	$f > 100\text{ kHz}$		1		pA/ $\sqrt{\text{Hz}}$	C	
	Current noise 1/f corner frequency			7		kHz	C	
	Overdrive recovery time	$G = 6$ , 2x output overdrive, DC-coupled		50		ns	C	
	Closed-loop output impedance	$f = 1\text{ MHz}$ , $G = 6$		0.3		$\Omega$	C	
<b>DC PERFORMANCE</b>								
$A_{OL}$	Open-loop voltage gain	$V_O = \pm 2\text{ V}$ , $R_L = 2\text{ k}\Omega$	120	125		dB	A	
	Input-referred offset voltage	$T_A \approx 25^\circ\text{C}$	-125	$\pm 15$	125	$\mu\text{V}$	A	
		$T_A = 0^\circ\text{C to } 70^\circ\text{C}$	-165	$\pm 15$	200		B	
		$T_A = -40^\circ\text{C to } 85^\circ\text{C}$	-230	$\pm 15$	220		B	
		$T_A = -40^\circ\text{C to } 125^\circ\text{C}$	-230	$\pm 15$	285		B	
	Input offset voltage drift <sup>(3)</sup>	$T_A = -40^\circ\text{C to } 125^\circ\text{C}$ <sup>(4)</sup>	-1.6	$\pm 0.4$	1.6	$\mu\text{V}/^\circ\text{C}$	B	
	Input bias current <sup>(5)</sup>	$T_A \approx 25^\circ\text{C}$	0.7	1.5	2.8	$\mu\text{A}$	A	
		$T_A = 0^\circ\text{C to } 70^\circ\text{C}$	.2	1.5	3.5		B	
		$T_A = -40^\circ\text{C to } 85^\circ\text{C}$	.2	1.5	3.7		B	
		$T_A = -40^\circ\text{C to } 125^\circ\text{C}$	.2	1.5	4.4		B	
	Input bias current drift <sup>(3)</sup>	$T_A = -40^\circ\text{C to } 125^\circ\text{C}$	4.5	7.8	17	nA/ $^\circ\text{C}$	B	
	Input offset current	$T_A \approx 25^\circ\text{C}$	-70	$\pm 20$	70	nA	A	
		$T_A = 0^\circ\text{C to } 70^\circ\text{C}$	-83	$\pm 20$	93		B	
		$T_A = -40^\circ\text{C to } 85^\circ\text{C}$	-105	$\pm 20$	100		B	
		$T_A = -40^\circ\text{C to } 125^\circ\text{C}$	-105	$\pm 20$	120		B	
	Input offset current drift <sup>(3)</sup>	$T_A = -40^\circ\text{C to } 125^\circ\text{C}$	-500	$\pm 40$	500	pA/ $^\circ\text{C}$	B	

- (1) Test levels (all values set by characterization and simulation): (A) 100% tested at 25°C, overtemperature limits by characterization and simulation; (B) Not tested in production, limits set by characterization and simulation; (C) Typical value only for information.
- (2) This slew rate is the average of the rising and falling time estimated from the large-signal bandwidth as:  $(0.8 \times V_{PEAK} / \sqrt{2}) \times 2\pi \times f_{-3dB}$  where this  $f_{-3dB}$  is the typical measured 4- $V_{PP}$  bandwidth at gains of 6 V/V.
- (3) Input offset voltage drift, input bias current drift, and input offset current drift are average values calculated by taking data at the end points, computing the difference, and dividing by the temperature range.
- (4) Input offset voltage drift, input bias current drift, and input offset current drift typical specifications are mean  $\pm 1\sigma$  characterized by the full temperature range end-point data. Maximum drift specifications are set by the min, max packaged test range on the wafer-level screened drift. Drift is not specified by the final automated test equipment (ATE) or by QA sample testing.
- (5) Current is considered positive out of the pin.

**Electrical Characteristics:  $V_S = 5\text{ V}$  (continued)**

at  $V_{S+} = 5\text{ V}$ ,  $V_{S-} = 0\text{ V}$ ,  $R_F = 1\text{ k}\Omega$ ,  $R_G = 200\ \Omega$ ,  $R_L = 2\text{ k}\Omega$ ,  $G = 6\text{ V/V}$ , input and output referenced to midsupply, and  $T_A \approx 25^\circ\text{C}$ , (unless otherwise noted)

PARAMETER		TEST CONDITIONS	MIN	TYP	MAX	UNIT	TEST LEVEL <sup>(1)</sup>
<b>INPUT</b>							
	Common-mode input range, low	$T_A \approx 25^\circ\text{C}$ , CMRR > 92 dB	$V_{S-} - 0.2$	$V_{S-} - 0$		V	A
		$T_A = -40^\circ\text{C}$ to $125^\circ\text{C}$ , CMRR > 92 dB	$V_{S-} - 0$				B
	Common-mode input range, high	$T_A \approx 25^\circ\text{C}$ , CMRR > 92 dB	$V_{S+} - 1.3$	$V_{S+} - 1.2$		V	A
		$T_A = -40^\circ\text{C}$ to $125^\circ\text{C}$ , CMRR > 92 dB	$V_{S+} - 1.3$				B
CMRR	Common-mode rejection ratio		95	105		dB	A
	Input impedance common-mode			35    1		M $\Omega$    pF	C
	Input impedance differential mode			30    1.3		k $\Omega$    pF	C
<b>OUTPUT</b>							
$V_{OL}$	Output voltage, low	$T_A \approx 25^\circ\text{C}$ , $G = 6$	$V_{S-} + 0.05$	$V_{S-} + 0.1$		V	A
		$T_A = -40^\circ\text{C}$ to $125^\circ\text{C}$ , $G = 6$	$V_{S-} + 0.05$	$V_{S-} + 0.1$			B
$V_{OH}$	Output voltage, high	$T_A \approx 25^\circ\text{C}$ , $G = 6$	$V_{S+} - 0.1$	$V_{S+} - 0.05$		V	A
		$T_A = -40^\circ\text{C}$ to $125^\circ\text{C}$ , $G = 6$	$V_{S+} - 0.2$	$V_{S+} - 0.1$			B
	Maximum current into a resistive load	$T_A \approx 25^\circ\text{C}$ , $\pm 1.53\text{ V}$ into $41.3\ \Omega$ , $V_{IO} < 2\text{ mV}$	$\pm 35$	$\pm 40$		mA	A
	Linear current into a resistive load	$T_A \approx 25^\circ\text{C}$ , $\pm 1.81\text{ V}$ into $70.6\ \Omega$ , $A_{OL} > 80\text{ dB}$	$\pm 25$	$\pm 28$		mA	A
		$T_A = -40^\circ\text{C}$ to $125^\circ\text{C}$ , $\pm 1.58\text{ V}$ into $70.6\ \Omega$ , $A_{OL} > 80\text{ dB}$	$\pm 22$	$\pm 25$			B
	DC output impedance	$G = 6$		0.02		$\Omega$	C
<b>POWER SUPPLY</b>							
	Specified operating voltage		2.7	5	5.4	V	B
	Quiescent operating current	$T_A \approx 25^\circ\text{C}$ <sup>(6)</sup>	913	960	993	$\mu\text{A}$	A
		$T_A = -40^\circ\text{C}$ to $125^\circ\text{C}$	700	960	1330		B
dlq/dT	Quiescent current temperature coefficient	$T_A = -40^\circ\text{C}$ to $125^\circ\text{C}$	2.6	3	3.4	$\mu\text{A}/^\circ\text{C}$	B
+PSRR	Positive power-supply rejection ratio		98	110		dB	A
-PSRR	Negative power-supply rejection ratio		93	105		dB	A
<b>POWER DOWN (Pin Must be Driven, SOT23-6 and SC70-6)</b>							
	Enable voltage threshold	Specified <i>on</i> above $V_{S-} + 1.5\text{ V}$	1.5			V	A
	Disable voltage threshold	Specified <i>off</i> below $V_{S-} + 0.55\text{ V}$			0.55	V	A
	Disable pin bias current	$\overline{\text{PD}} = V_{S-}$ to $V_{S+}$	-50	20	50	nA	A
	Power-down quiescent current	$\overline{\text{PD}} = 0.55\text{ V}$		0.1	1	$\mu\text{A}$	A
	Turnon time delay	Time from $\overline{\text{PD}} = \text{high}$ to $V_{OUT} = 90\%$ of final value		1.7		usec	C
	Turnoff time delay	Time from $\overline{\text{PD}} = \text{low}$ to $V_{OUT} = 10\%$ of original value		100		ns	C

(6) The typical specification is at  $25^\circ\text{C}$   $T_J$ . The minimum and maximum limits are expanded for the ATE to account for an ambient range from  $22^\circ\text{C}$  to  $32^\circ\text{C}$  with a  $4\text{-}\mu\text{A}/^\circ\text{C}$  temperature coefficient on the supply current.

## 7.6 Electrical Characteristics: $V_S = 3\text{ V}$

at  $V_{S+} = 3\text{ V}$ ,  $V_{S-} = 0\text{ V}$ ,  $R_F = 1\text{ k}\Omega$ ,  $R_G = 200\ \Omega$ ,  $R_L = 2\text{ k}\Omega$ ,  $G = 6\text{ V/V}$ , input and output referenced to midsupply, and  $T_A \approx 25^\circ\text{C}$ , (unless otherwise noted)

PARAMETER		TEST CONDITIONS	MIN	TYP	MAX	UNIT	TEST LEVEL <sup>(1)</sup>	
<b>AC PERFORMANCE</b>								
SSBW	Small-signal bandwidth	$V_{OUT} = 20\text{ mV}_{PP}$ , $G = 6$ (peaking < 4 dB)	70	86		MHz	C	
		$V_{OUT} = 20\text{ mV}_{PP}$ , $G = 10$ , $R_F = 1.6\text{ k}\Omega$		50			C	
		$V_{OUT} = 20\text{ mV}_{PP}$ , $G = 100$ , $R_F = 16.9\text{ k}\Omega$		3			C	
GBP	Gain-bandwidth product	$V_{OUT} = 20\text{ mV}_{PP}$ , $G = 100$	240	300		MHz	C	
LSBW	Large-signal bandwidth	$V_{OUT} = 2\text{ V}_{PP}$ , $G = 6$		45		MHz	C	
		Bandwidth for 0.1-dB flatness	$V_{OUT} = 200\text{ mV}_{PP}$ , $G = 6$		9		MHz	C
SR	Slew rate	From LSBW <sup>(2)</sup>	250	350		V/ $\mu\text{s}$	C	
		Overshoot, undershoot	$V_{OUT} = 1\text{-V step}$ , $G = 6$ , input $t_R = 6\text{ ns}$		2%	4%		C
$t_R$ , $t_F$	Rise, fall time	$V_{OUT} = 1\text{-V step}$ , $G = 6$ , input $t_R = 6\text{ ns}$		6.3	7	ns	C	
		Settling time to 0.1%	$V_{OUT} = 1\text{-V step}$ , $G = 6$ , input $t_R = 6\text{ ns}$		30		ns	C
		Settling time to 0.01%	$V_{OUT} = 1\text{-V step}$ , $G = 6$ , input $t_R = 6\text{ ns}$		40		ns	C
HD2	Second-order harmonic distortion	$f = 100\text{ kHz}$ , $V_O = 2\text{ V}_{PP}$ , $G = 6$ (see Figure 74)		-108		dBc	C	
HD3	Third-order harmonic distortion	$f = 100\text{ kHz}$ , $V_O = 2\text{ V}_{PP}$ , $G = 6$ (see Figure 74)		-125		dBc	C	
	Input voltage noise	$f > 1\text{ kHz}$		1.8		nV/ $\sqrt{\text{Hz}}$	C	
	Voltage noise 1/f corner frequency			100		Hz	C	
	Input current noise	$f > 100\text{ kHz}$		1.0		pA/ $\sqrt{\text{Hz}}$	C	
	Current noise 1/f corner frequency			7		kHz	C	
	Overdrive recovery time	$G = 6$ , 2x output overdrive, DC-coupled		50		ns	C	
	Closed-loop output impedance	$f = 1\text{ MHz}$ , $G = 6$		0.3		$\Omega$	C	
<b>DC PERFORMANCE</b>								
$A_{OL}$	Open-loop voltage gain	$V_O = \pm 1\text{ V}$ , $R_L = 2\text{ k}\Omega$	110	125		dB	A	
	Input-referred offset voltage	$T_A \approx 25^\circ\text{C}$	-125	$\pm 15$	125	$\mu\text{V}$	A	
		$T_A = 0^\circ\text{C to } 70^\circ\text{C}$	-165	$\pm 15$	200		B	
		$T_A = -40^\circ\text{C to } 85^\circ\text{C}$	-230	$\pm 15$	220		B	
		$T_A = -40^\circ\text{C to } 125^\circ\text{C}$	-230	$\pm 15$	285		B	
	Input offset voltage drift <sup>(3)</sup>	$T_A = -40^\circ\text{C to } 125^\circ\text{C}$ <sup>(4)</sup>	-1.6	$\pm 0.4$	1.6	$\mu\text{V}/^\circ\text{C}$	B	
	Input bias current <sup>(5)</sup>	$T_A \approx 25^\circ\text{C}$	.7	1.5	2.8	$\mu\text{A}$	A	
		$T_A = 0^\circ\text{C to } 70^\circ\text{C}$	.2	1.5	3.5		B	
		$T_A = -40^\circ\text{C to } 85^\circ\text{C}$	.2	1.5	3.7		B	
		$T_A = -40^\circ\text{C to } 125^\circ\text{C}$	.2	1.5	4.4		B	
	Input bias current drift <sup>(3)</sup>	$T_A = -40^\circ\text{C to } 125^\circ\text{C}$	4.5	7.8	17	nA/ $^\circ\text{C}$	B	
	Input offset current	$T_A \approx 25^\circ\text{C}$	-70	$\pm 20$	70	nA	A	
		$T_A = 0^\circ\text{C to } 70^\circ\text{C}$	-83	$\pm 20$	93		B	
		$T_A = -40^\circ\text{C to } 85^\circ\text{C}$	-105	$\pm 20$	100		B	
		$T_A = -40^\circ\text{C to } 125^\circ\text{C}$	-105	$\pm 13$	120		B	
	Input offset current drift <sup>(3)</sup>	$T_A = -40^\circ\text{C to } 125^\circ\text{C}$	-500	$\pm 20$	500	pA/ $^\circ\text{C}$	B	

- (1) Test levels (all values set by characterization and simulation): (A) 100% tested at 25°C, overtemperature limits by characterization and simulation; (B) Not tested in production, limits set by characterization and simulation; (C) Typical value only for information.
- (2) This slew rate is the average of the rising and falling time estimated from the large-signal bandwidth as:  $(0.8 \times V_{PEAK} / \sqrt{2}) \times 2\pi \times f_{-3dB}$  where this  $f_{-3dB}$  is the typical measured 2- $V_{PP}$  bandwidth at gains of 6 V/V.
- (3) Input offset voltage drift, input bias current drift, and input offset current drift are average values calculated by taking data at the end points, computing the difference, and dividing by the temperature range.
- (4) Input offset voltage drift, input bias current drift, and input offset current drift typical specifications are mean  $\pm 1\sigma$  characterized by the full temperature range end-point data. Maximum drift specifications are set by the min, max packaged test range on the wafer-level screened drift. Drift is not specified by the final automated test equipment (ATE) or by QA sample testing.
- (5) Current is considered positive out of the pin.



**Electrical Characteristics:  $V_S = 3\text{ V}$  (continued)**

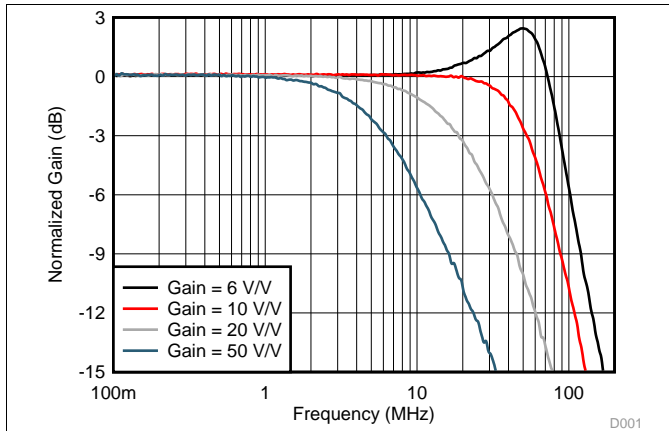
at  $V_{S+} = 3\text{ V}$ ,  $V_{S-} = 0\text{ V}$ ,  $R_F = 1\text{ k}\Omega$ ,  $R_G = 200\ \Omega$ ,  $R_L = 2\text{ k}\Omega$ ,  $G = 6\text{ V/V}$ , input and output referenced to midsupply, and  $T_A \approx 25^\circ\text{C}$ , (unless otherwise noted)

PARAMETER		TEST CONDITIONS	MIN	TYP	MAX	UNIT	TEST LEVEL <sup>(1)</sup>
<b>INPUT</b>							
	Common-mode input range, low	$T_A \approx 25^\circ\text{C}$ , CMRR > 92 dB	$V_{S-} - 0.2$	$V_{S-} - 0$		V	A
		$T_A = -40^\circ\text{C}$ to $125^\circ\text{C}$ , CMRR > 92 dB	$V_{S-} - 0$				B
	Common-mode input range, high	$T_A \approx 25^\circ\text{C}$ , CMRR > 92 dB	$V_{S+} - 1.3$	$V_{S+} - 1.2$		V	A
		$T_A = -40^\circ\text{C}$ to $125^\circ\text{C}$ , CMRR > 92 dB	$V_{S+} - 1.3$				B
CMRR	Common-mode rejection ratio		95	105		dB	A
	Input impedance common-mode			$55 \parallel 1.1$		$\text{M}\Omega \parallel \text{pF}$	C
	Input impedance differential mode			$30 \parallel 1.3$		$\text{k}\Omega \parallel \text{pF}$	C
<b>OUTPUT</b>							
$V_{OL}$	Output voltage, low	$T_A \approx 25^\circ\text{C}$ , $G = 6$	$V_{S-} + 0.05$	$V_{S-} + 0.1$		V	A
		$T_A = -40^\circ\text{C}$ to $125^\circ\text{C}$ , $G = 6$	$V_{S-} + 0.1$	$V_{S-} + 0.2$			B
$V_{OH}$	Output voltage, high	$T_A \approx 25^\circ\text{C}$ , $G = 6$	$V_{S+} - 0.1$	$V_{S+} - 0.05$		V	A
		$T_A = -40^\circ\text{C}$ to $125^\circ\text{C}$ , $G = 6$	$V_{S+} - 0.2$	$V_{S+} - 0.1$			B
	Maximum current into a resistive load	$T_A \approx 25^\circ\text{C}$ , $\pm 0.77\text{ V}$ into $26.7\ \Omega$ , $V_{IO} < 2\text{ mV}$	$\pm 28$	$\pm 30$		mA	A
	Linear current into a resistive load	$T_A \approx 25^\circ\text{C}$ , $\pm 0.88\text{ V}$ into $37\ \Omega$ , $A_{OL} > 70\text{ dB}$	$\pm 23$	$\pm 25$		mA	A
		$T_A = -40^\circ\text{C}$ to $125^\circ\text{C}$ , $\pm 0.76\text{ V}$ into $37\ \Omega$ , $A_{OL} > 70\text{ dB}$	$\pm 20$	$\pm 23$			B
	DC output impedance	$G = 6$		0.02		$\Omega$	C
<b>POWER SUPPLY</b>							
	Specified operating voltage		2.7	5	5.4	V	B
	Quiescent operating current	$T_A \approx 25^\circ\text{C}$ <sup>(6)</sup>	890	930	970	$\mu\text{A}$	A
		$T_A = -40^\circ\text{C}$ to $125^\circ\text{C}$	680	930	1290		B
dIq/dT	Quiescent current temperature coefficient	$T_A = -40^\circ\text{C}$ to $125^\circ\text{C}$	2.2	2.7	3.2	$\mu\text{A}/^\circ\text{C}$	B
+PSRR	Positive power-supply rejection ratio		95	110		dB	A
-PSRR	Negative power-supply rejection ratio		90	105		dB	A
<b>POWER DOWN (Pin Must be Driven, SOT23-6 and SC70-6)</b>							
	Enable voltage threshold	Specified on above $V_{S-} + 1.5\text{ V}$	1.5			V	A
	Disable voltage threshold	Specified off below $V_{S-} + 0.55\text{ V}$			0.55	V	A
	Disable pin bias current	$\overline{\text{PD}} = V_{S-}$ to $V_{S+}$	-50	20	50	nA	A
	Power-down quiescent current	$\overline{\text{PD}} = 0.55\text{ V}$		0.1	1	$\mu\text{A}$	A
	Turnon time delay	Time from $\overline{\text{PD}} = \text{high}$ to $V_{OUT} = 90\%$ of final value		3.5		usec	C
	Turnoff time delay	Time from $\overline{\text{PD}} = \text{low}$ to $V_{OUT} = 10\%$ of original value		100		ns	C

(6) The typical specification is at  $25^\circ\text{C}$   $T_J$ . The minimum and maximum limits are expanded for the ATE to account for an ambient range from  $22^\circ\text{C}$  to  $32^\circ\text{C}$  with a  $4\text{-}\mu\text{A}/^\circ\text{C}$  temperature coefficient on the supply current.

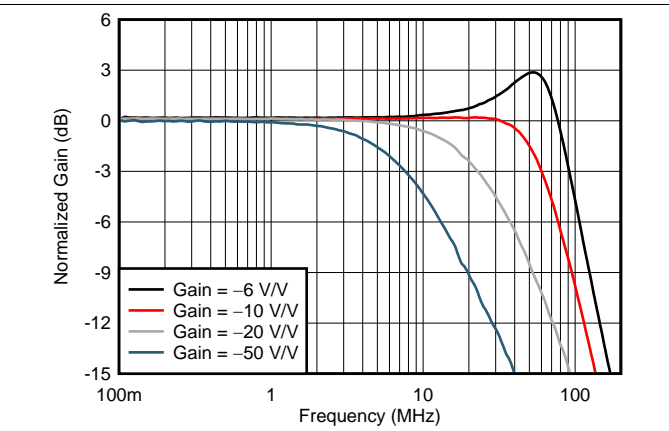
### 7.7 Typical Characteristics: $V_S = 5\text{ V}$

$V_{S+} = 5\text{ V}$ ,  $V_{S-} = 0\text{ V}$ ,  $R_F = 1\text{ k}\Omega$ ,  $R_G = 200\ \Omega$ ,  $R_L = 2\text{ k}\Omega$ ,  $G = 6\text{ V/V}$ , input and output referenced to midsupply,  $T_A \approx 25^\circ\text{C}$  (unless otherwise noted)



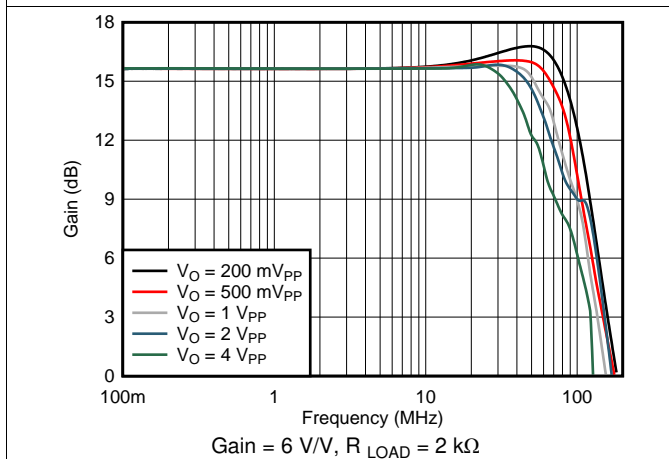
See Figure 74 and Table 1 ( $V_O = 20\text{ mV}_{PP}$ ,  $R_{LOAD} = 2\text{ k}\Omega$ )

**Figure 1. Noninverting Small-Signal Frequency Response vs Gain**

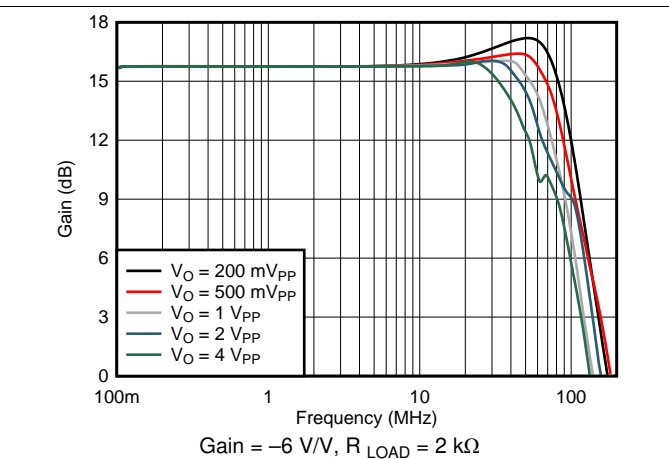


See Figure 75 and Table 2 ( $V_O = 20\text{ mV}_{PP}$ ,  $R_{LOAD} = 2\text{ k}\Omega$ )

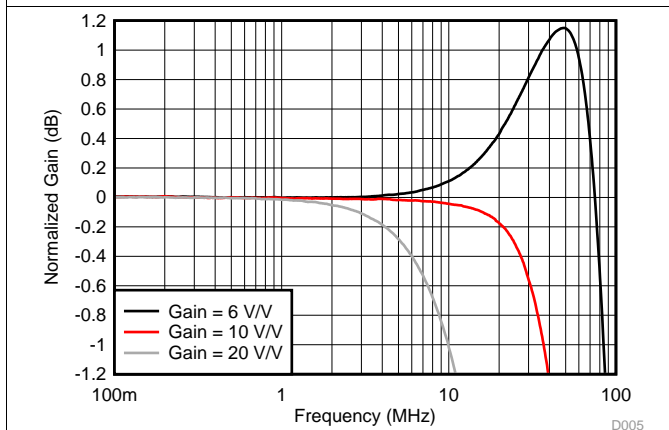
**Figure 2. Inverting Small-Signal Frequency Response vs Gain**



**Figure 3. Noninverting Large-Signal Bandwidth vs  $V_{OPP}$**

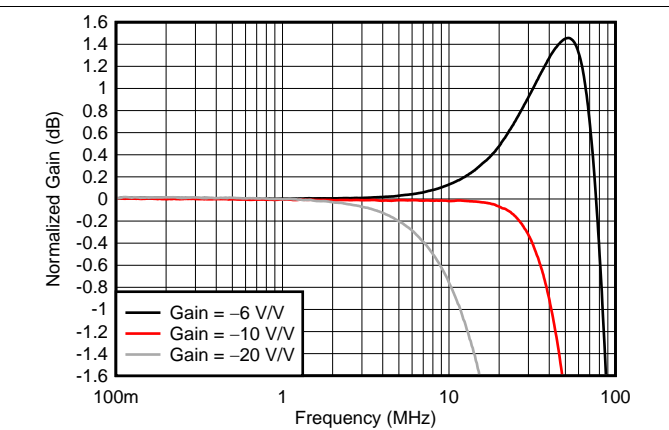


**Figure 4. Inverting Large-Signal Bandwidth vs  $V_{OPP}$**



See Figure 74 and Table 1 ( $V_O = 200\text{ mV}_{PP}$ ,  $R_{LOAD} = 2\text{ k}\Omega$ )

**Figure 5. Noninverting Response Flatness vs Gain**



See Figure 75 and Table 2 ( $V_O = 200\text{ mV}_{PP}$ ,  $R_{LOAD} = 2\text{ k}\Omega$ )

**Figure 6. Inverting Response Flatness vs Gain**

Typical Characteristics:  $V_S = 5\text{ V}$  (continued)

$V_{S+} = 5\text{ V}$ ,  $V_{S-} = 0\text{ V}$ ,  $R_F = 1\text{ k}\Omega$ ,  $R_G = 200\ \Omega$ ,  $R_L = 2\text{ k}\Omega$ ,  $G = 6\text{ V/V}$ , input and output referenced to midsupply,  $T_A \approx 25^\circ\text{C}$  (unless otherwise noted)

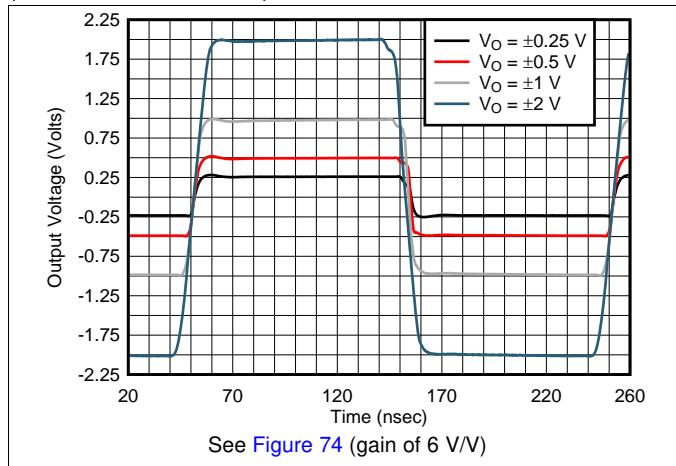


Figure 7. Noninverting Step Response vs  $V_{OPP}$

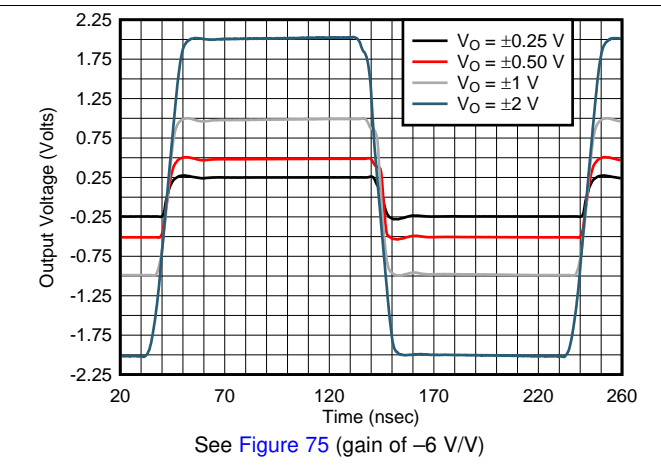


Figure 8. Inverting Step Response vs  $V_{OPP}$

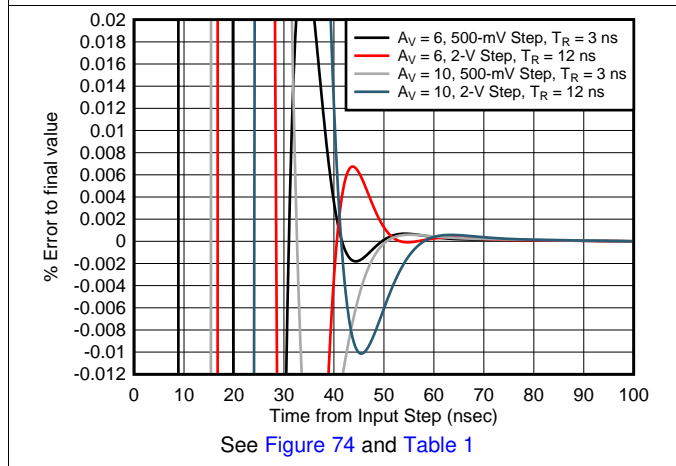


Figure 9. Simulated Noninverting Settling Time

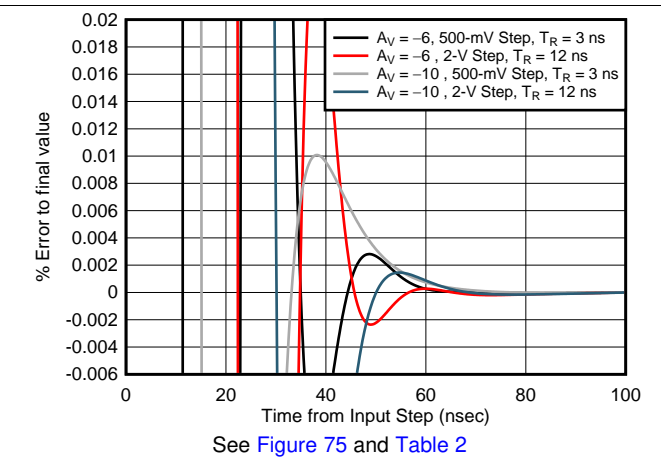


Figure 10. Simulated Inverting Settling Time

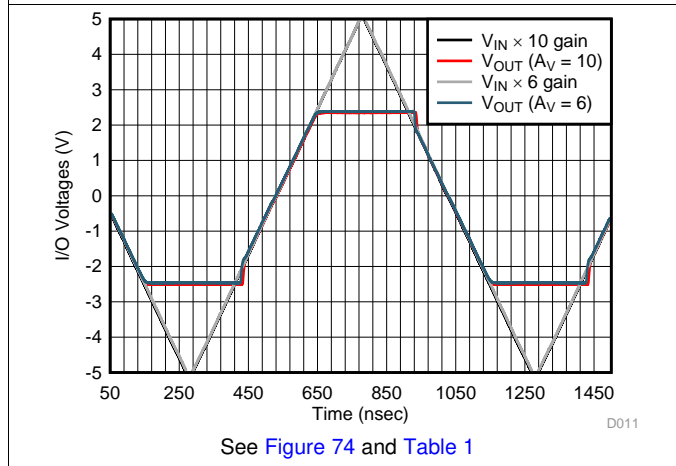


Figure 11. Noninverting Overdrive Recovery

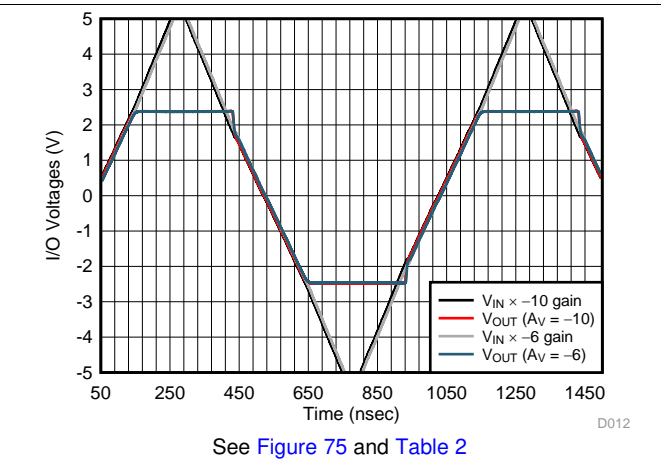
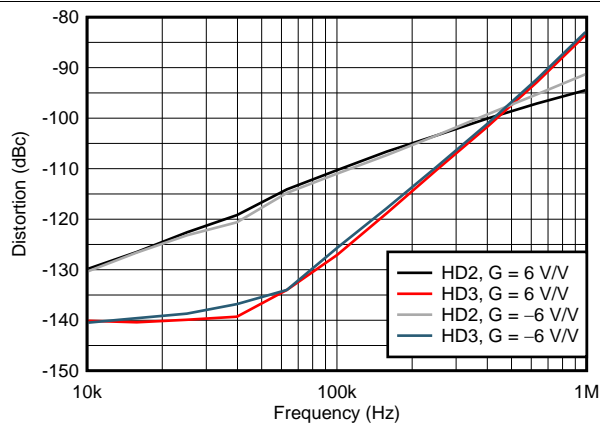


Figure 12. Inverting Overdrive Recovery

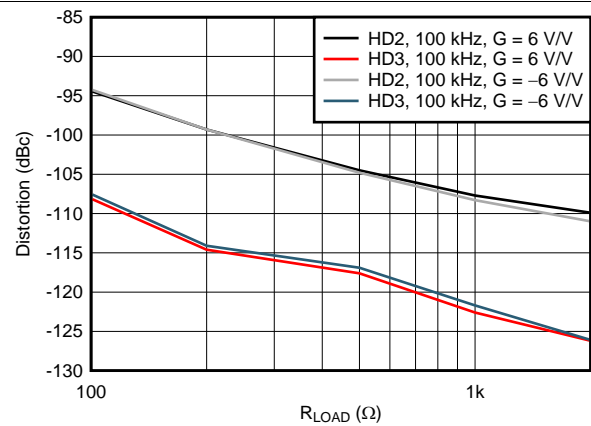
**Typical Characteristics:  $V_S = 5\text{ V}$  (continued)**

$V_{S+} = 5\text{ V}$ ,  $V_{S-} = 0\text{ V}$ ,  $R_F = 1\text{ k}\Omega$ ,  $R_G = 200\ \Omega$ ,  $R_L = 2\text{ k}\Omega$ ,  $G = 6\text{ V/V}$ , input and output referenced to midsupply,  $T_A \approx 25^\circ\text{C}$  (unless otherwise noted)



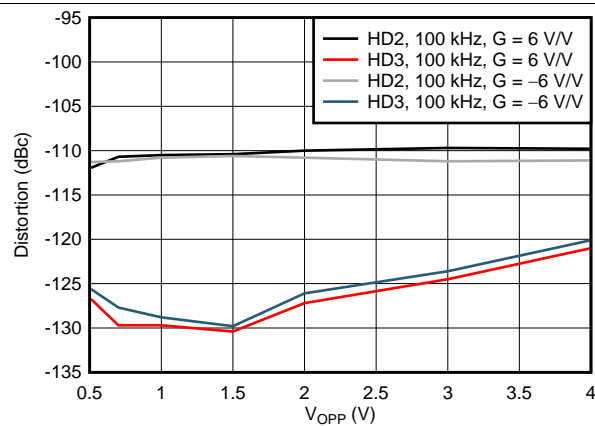
See Figure 74, Figure 75, Table 1, and Table 2

**Figure 13. Harmonic Distortion vs Frequency**



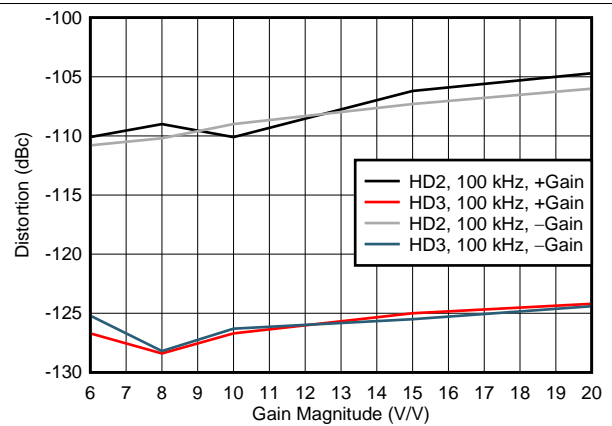
See Figure 74, Figure 75, Table 1, and Table 2  
( $V_O = 2\text{ V}_{PP}$ ,  $F = 100\text{ kHz}$ )

**Figure 14. Harmonic Distortion vs  $R_{LOAD}$**



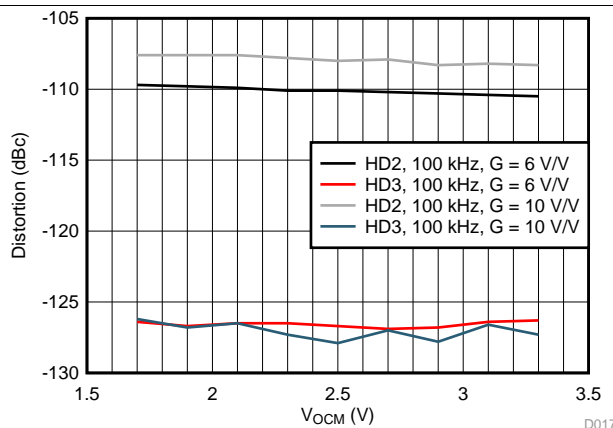
See Figure 74, Figure 75, Table 1, and Table 2  
( $F = 100\text{ kHz}$ ,  $R_{LOAD} = 2\text{ k}\Omega$ )

**Figure 15. Harmonic Distortion vs Output Swing**



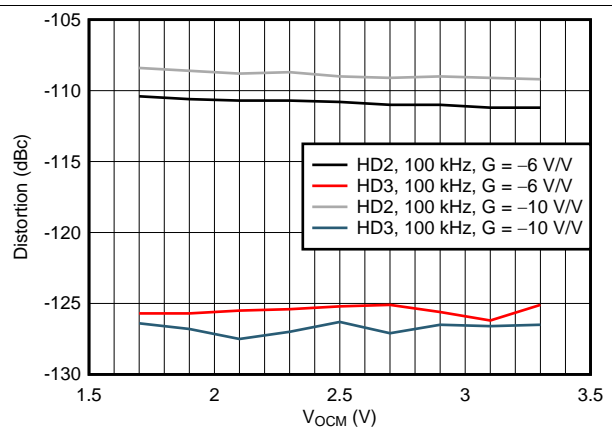
See Figure 74, Figure 75, Table 1, and Table 2  
( $V_O = 2\text{ V}_{PP}$ ,  $R_{LOAD} = 2\text{ k}\Omega$ ,  $F = 100\text{ kHz}$ )

**Figure 16. Harmonic Distortion vs Gain**



See Figure 74 and Table 1  
( $V_O = 2\text{ V}_{PP}$ ,  $F = 100\text{ kHz}$ ,  $R_{LOAD} = 2\text{ k}\Omega$ )

**Figure 17. Noninverting Distortion vs Output Common-Mode Voltage**

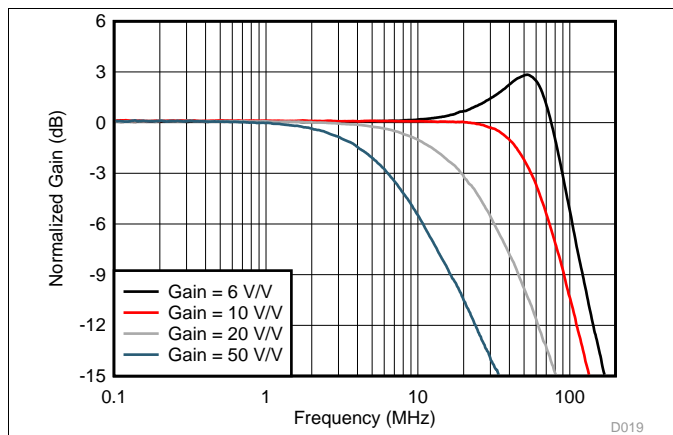


See Figure 75 and Table 2  
( $V_O = 2\text{ V}_{PP}$ ,  $F = 100\text{ kHz}$ ,  $R_{LOAD} = 2\text{ k}\Omega$ )

**Figure 18. Inverting Distortion vs Output Common-Mode Voltage**

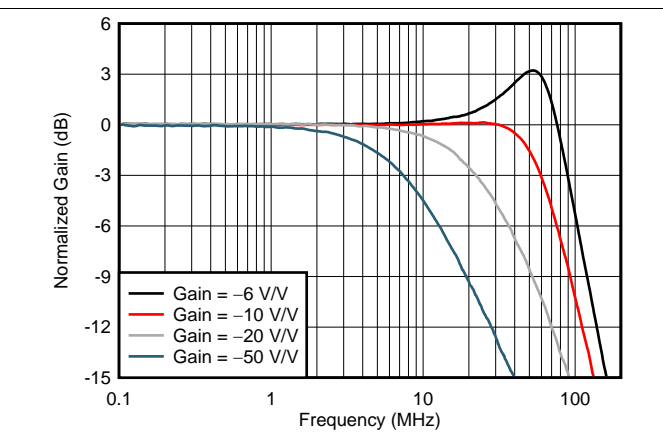
### 7.8 Typical Characteristics: $V_S = 3\text{ V}$

$V_{S+} = 3\text{ V}$ ,  $V_{S-} = 0\text{ V}$ ,  $R_F = 1\text{ k}\Omega$ ,  $R_G = 200\ \Omega$ ,  $R_L = 2\text{ k}\Omega$ ,  $G = 6\text{ V/V}$ , input and output referenced to midsupply.  $T_A = 25^\circ\text{C}$  (unless otherwise noted)



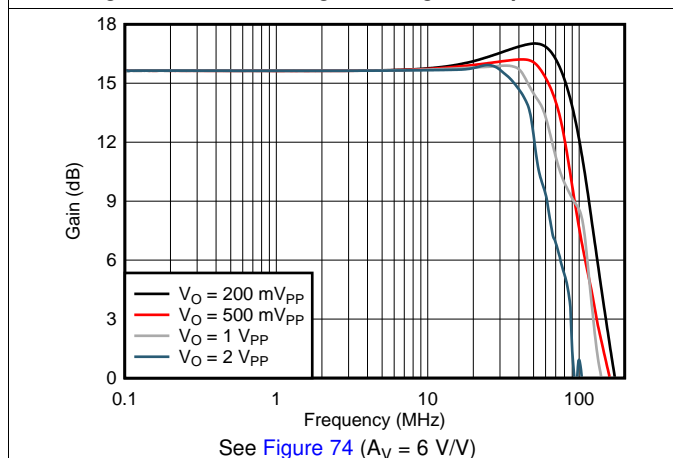
See Figure 74 and Table 1

Figure 19. Noninverting Small-Signal Response vs Gain



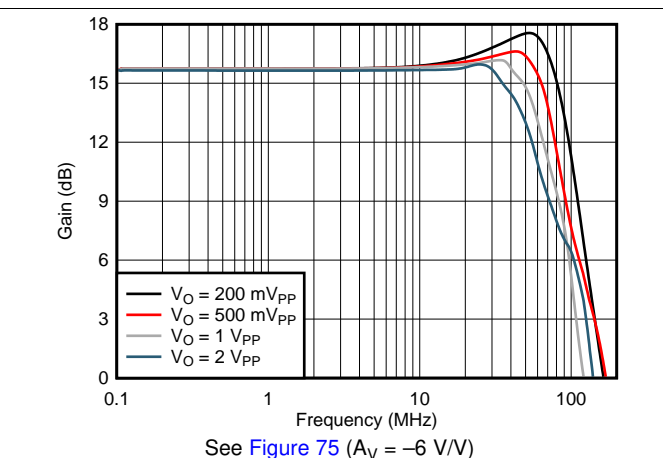
See Figure 75 and Table 2

Figure 20. Inverting Small-Signal Response vs Gain



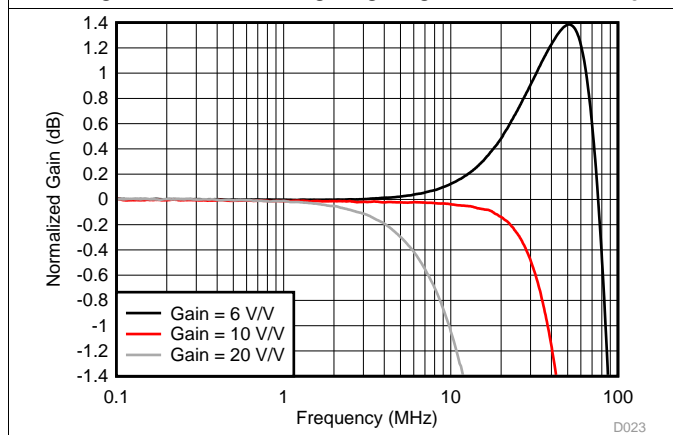
See Figure 74 ( $A_V = 6\text{ V/V}$ )

Figure 21. Noninverting Large-Signal Bandwidth vs  $V_{OPP}$



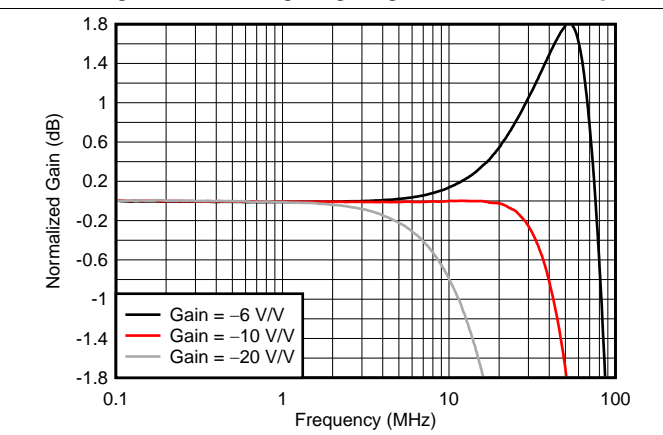
See Figure 75 ( $A_V = -6\text{ V/V}$ )

Figure 22. Inverting Large-Signal Bandwidth vs  $V_{OPP}$



See Figure 74 and Table 1 ( $V_O = 200\text{ mV}_{PP}$ ,  $R_{LOAD} = 2\text{ k}\Omega$ )

Figure 23. Noninverting Response Flatness vs Gain

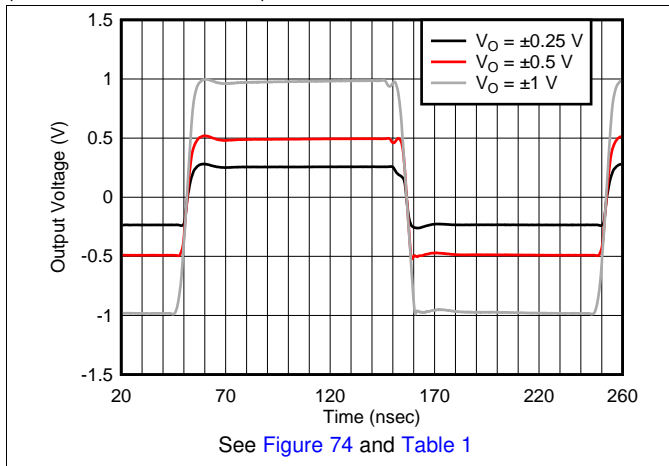


See Figure 75 and Table 2 ( $V_O = 200\text{ mV}_{PP}$ ,  $R_{LOAD} = 2\text{ k}\Omega$ )

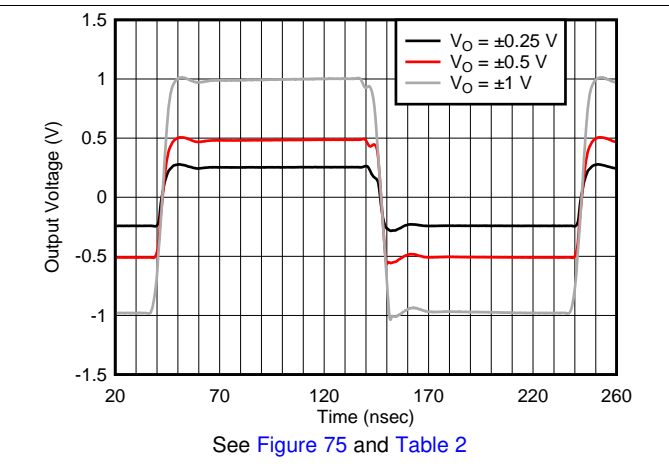
Figure 24. Inverting Response Flatness vs Gain

**Typical Characteristics:  $V_S = 3\text{ V}$  (continued)**

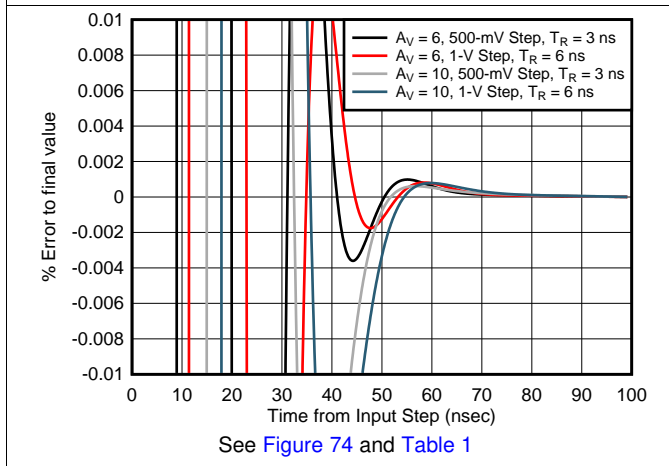
$V_{S+} = 3\text{ V}$ ,  $V_{S-} = 0\text{ V}$ ,  $R_F = 1\text{ k}\Omega$ ,  $R_G = 200\ \Omega$ ,  $R_L = 2\text{ k}\Omega$ ,  $G = 6\text{ V/V}$ , input and output referenced to midsupply.  $T_A = 25^\circ\text{C}$  (unless otherwise noted)



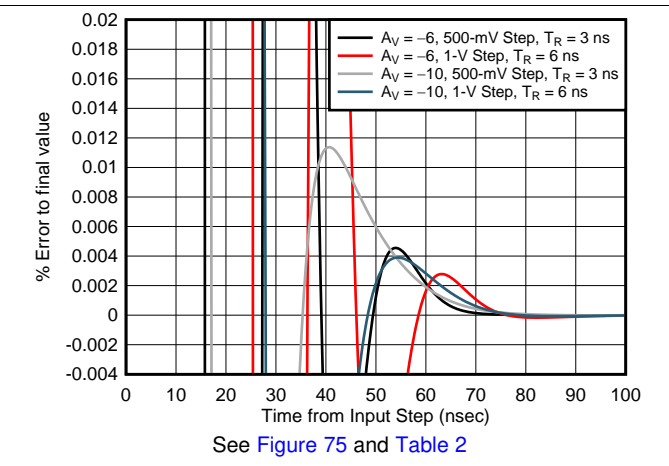
**Figure 25. Noninverting Step Response vs  $V_{OPP}$**



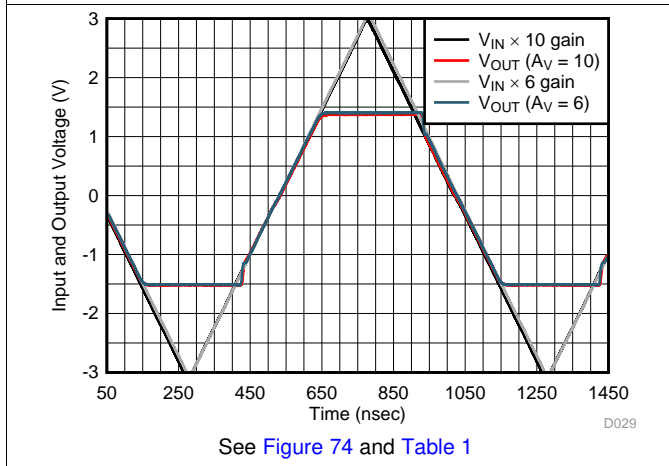
**Figure 26. Inverting Step Response vs  $V_{OPP}$**



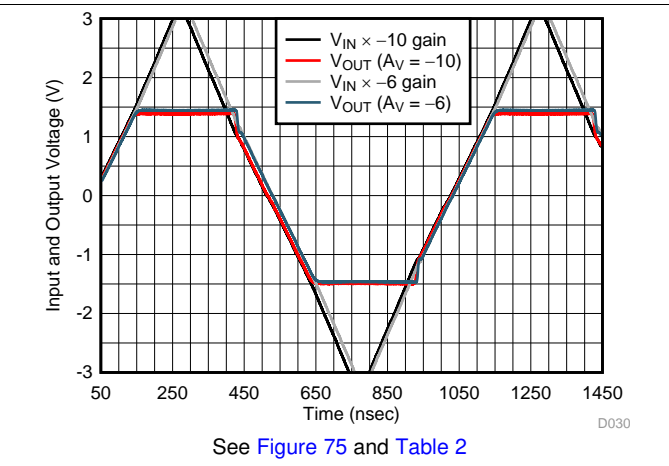
**Figure 27. Noninverting Settling Time**



**Figure 28. Inverting Settling Time**



**Figure 29. Noninverting Overdrive Recovery**



**Figure 30. Inverting Overdrive Recovery**

Typical Characteristics:  $V_S = 3\text{ V}$  (continued)

$V_{S+} = 3\text{ V}$ ,  $V_{S-} = 0\text{ V}$ ,  $R_F = 1\text{ k}\Omega$ ,  $R_G = 200\ \Omega$ ,  $R_L = 2\text{ k}\Omega$ ,  $G = 6\text{ V/V}$ , input and output referenced to midsupply.  $T_A = 25^\circ\text{C}$  (unless otherwise noted)

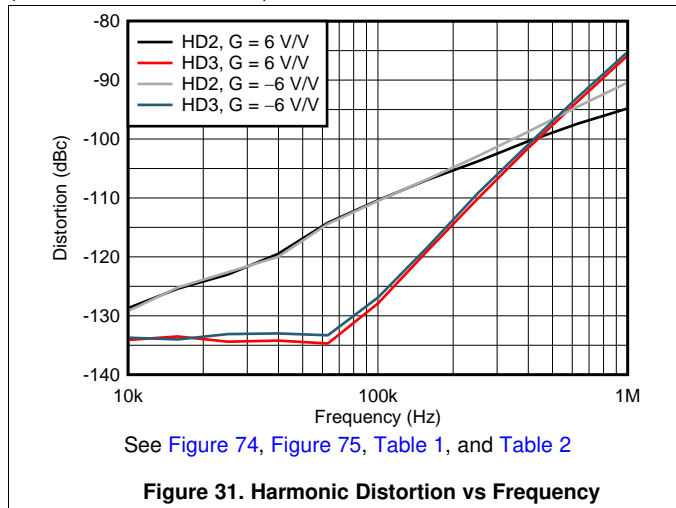


Figure 31. Harmonic Distortion vs Frequency

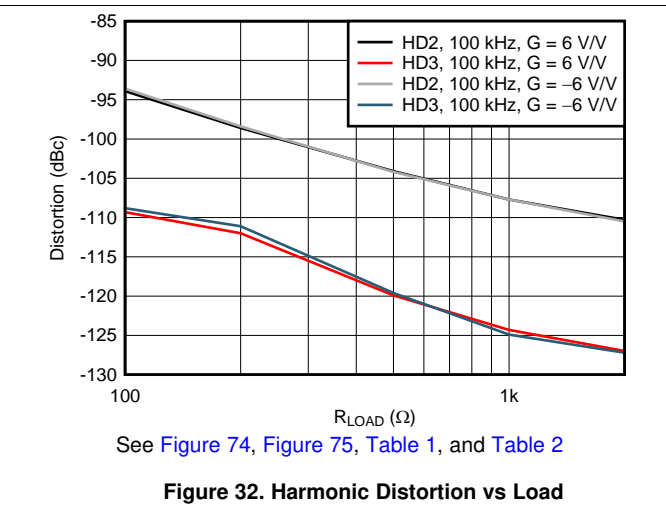


Figure 32. Harmonic Distortion vs Load

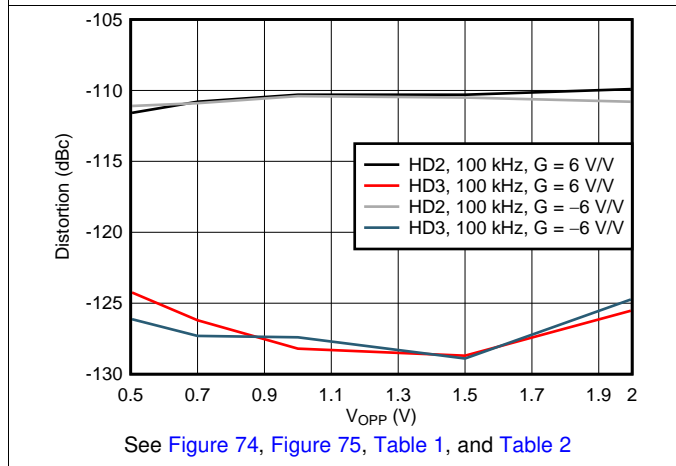


Figure 33. Harmonic Distortion vs Output Swing

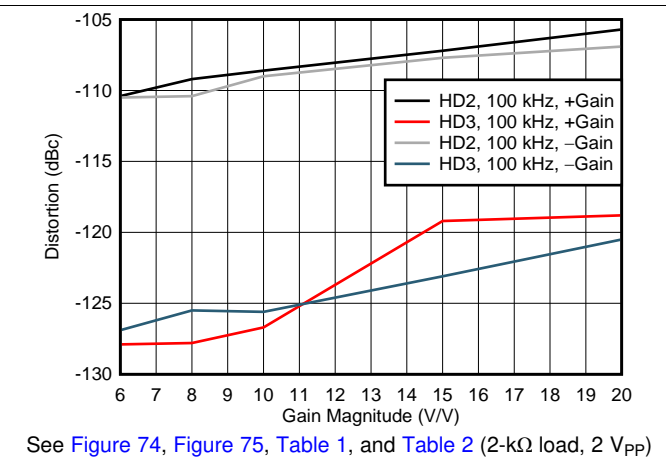


Figure 34. Harmonic Distortion vs Gain

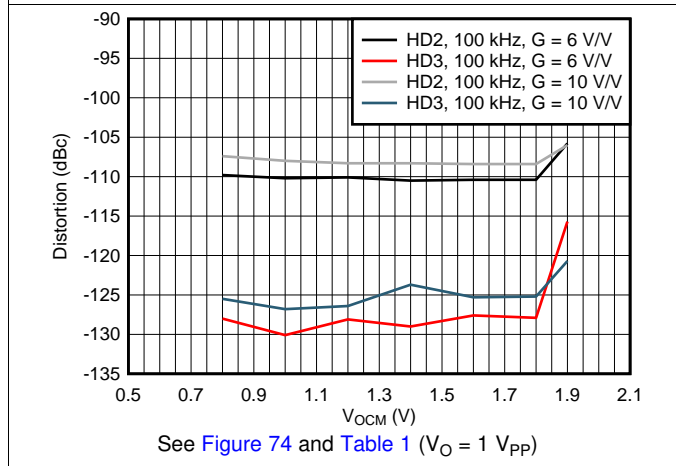


Figure 35. Noninverting Harmonic Distortion vs Output Common-Mode Voltage

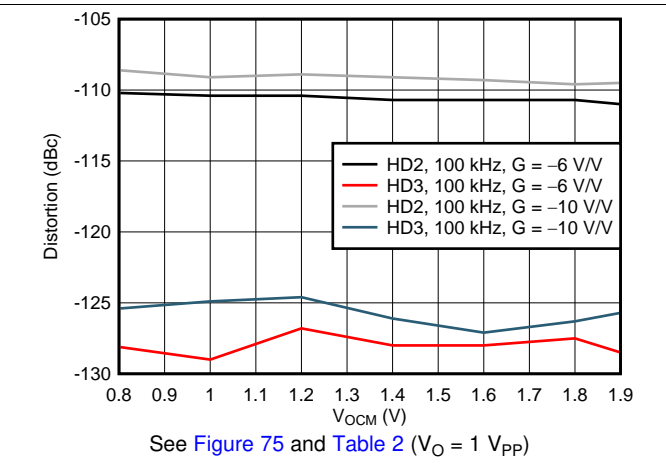


Figure 36. Inverting Harmonic Distortion vs Output Common-Mode Voltage

## 7.9 Typical Characteristics: Over Supply Range

$\overline{PD} = V_{S+}$  and  $T_A = 25^\circ\text{C}$  (unless otherwise noted)

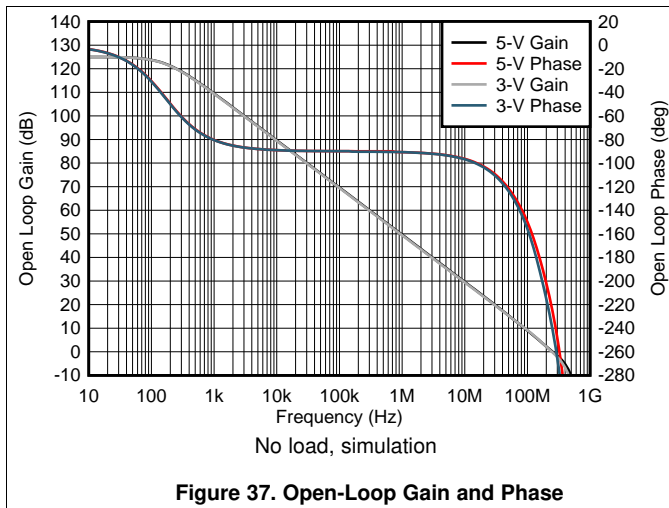


Figure 37. Open-Loop Gain and Phase

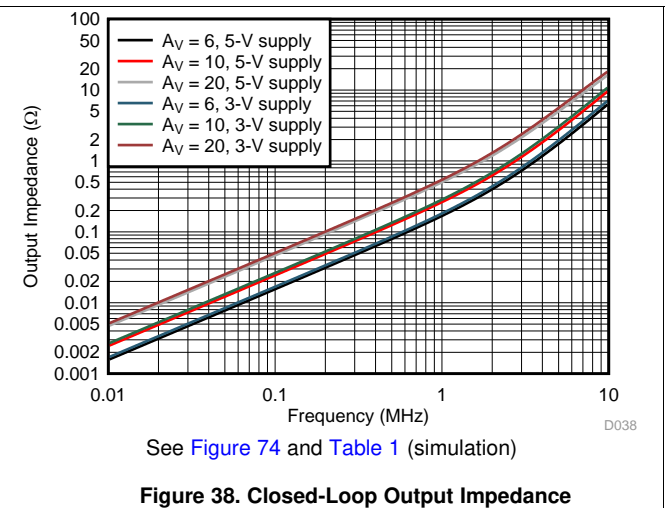


Figure 38. Closed-Loop Output Impedance

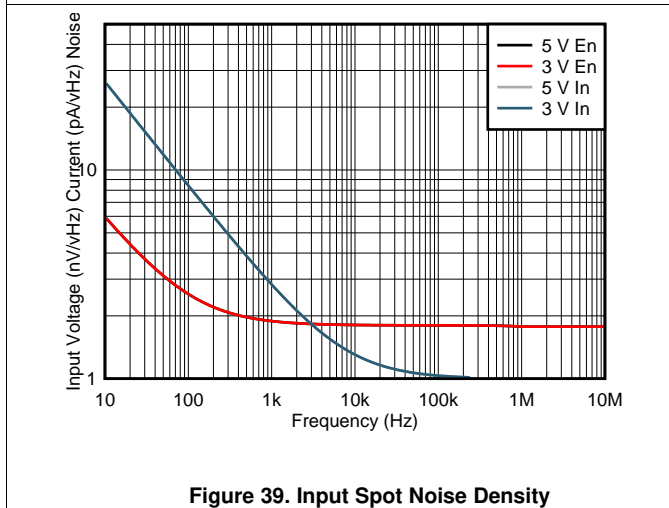


Figure 39. Input Spot Noise Density

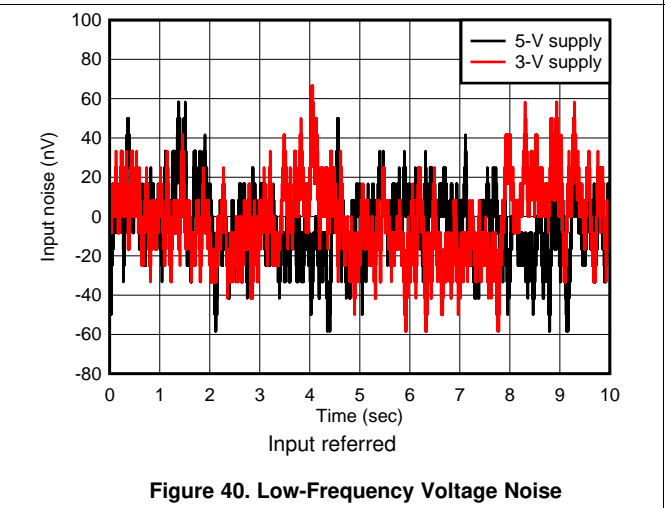


Figure 40. Low-Frequency Voltage Noise

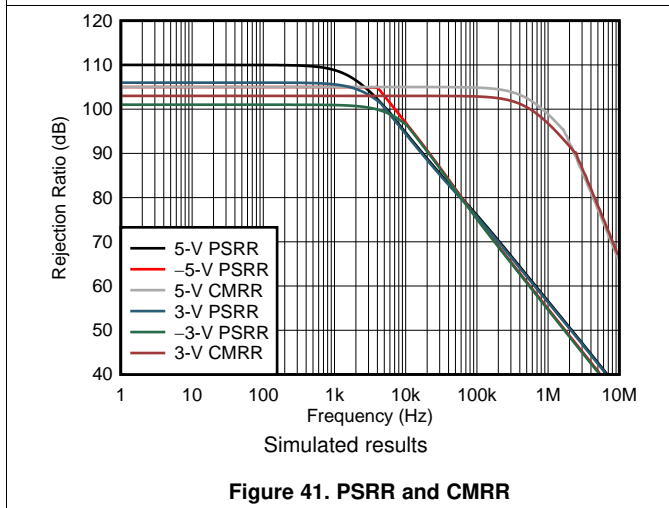


Figure 41. PSRR and CMRR

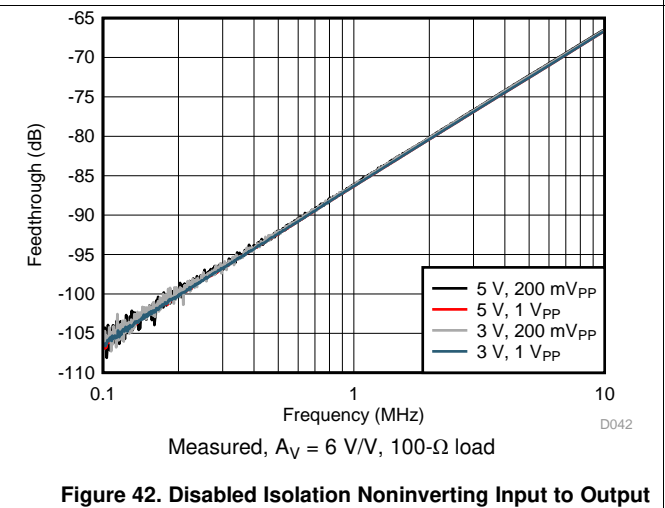
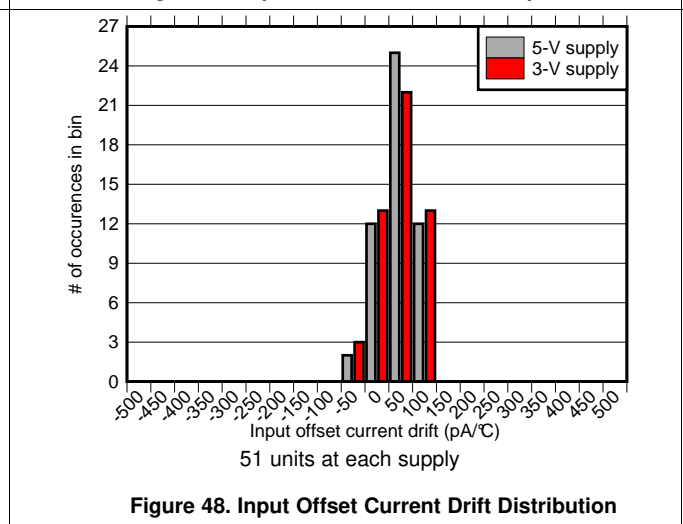
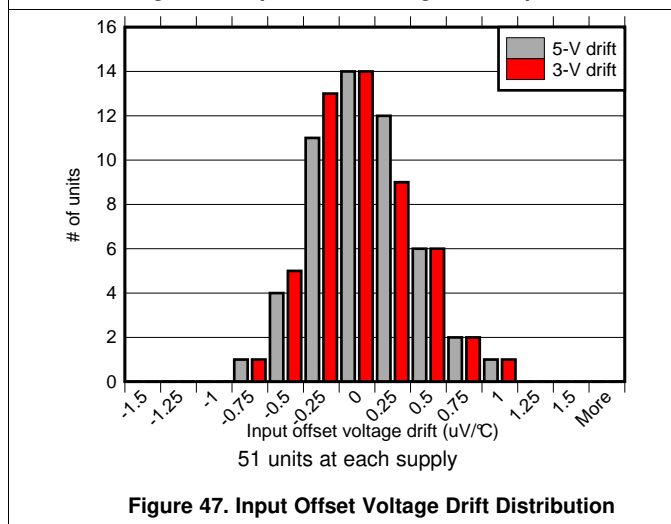
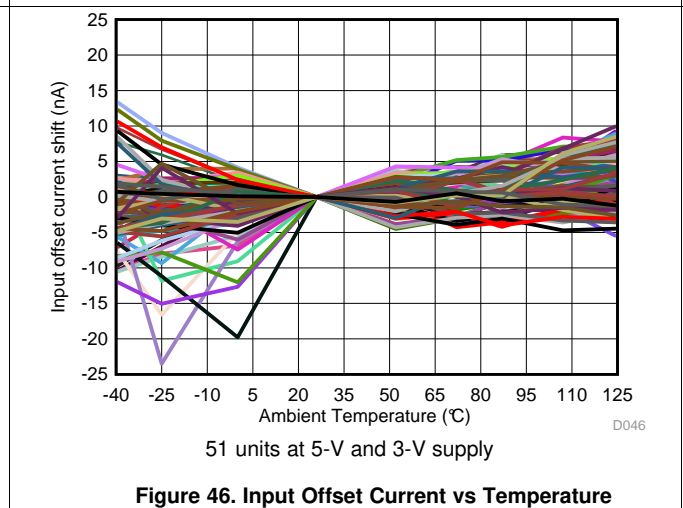
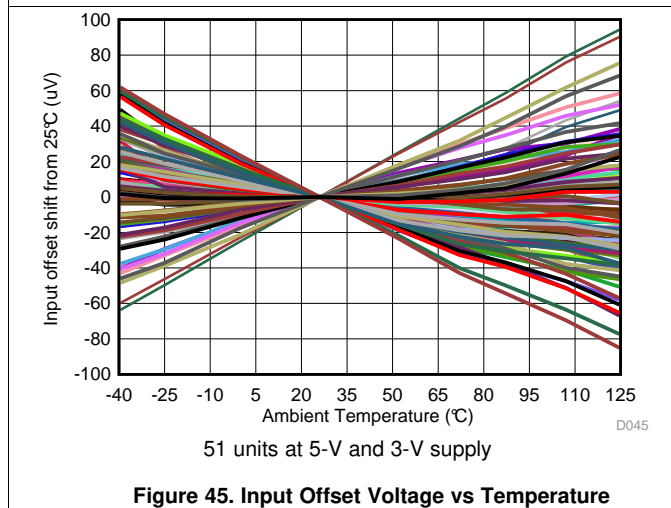
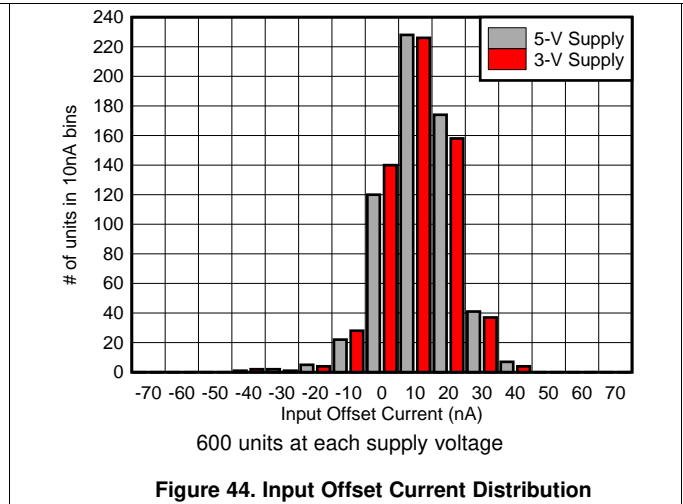
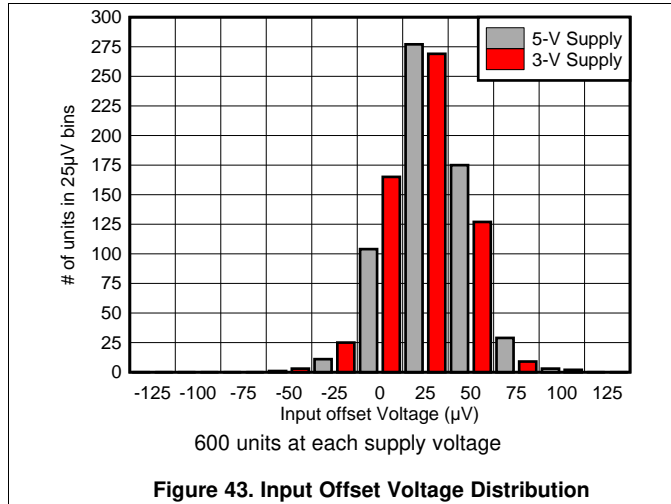


Figure 42. Disabled Isolation Noninverting Input to Output



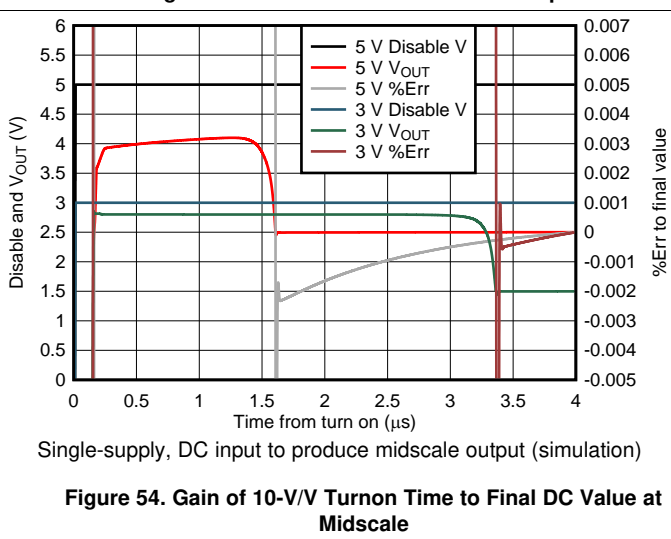
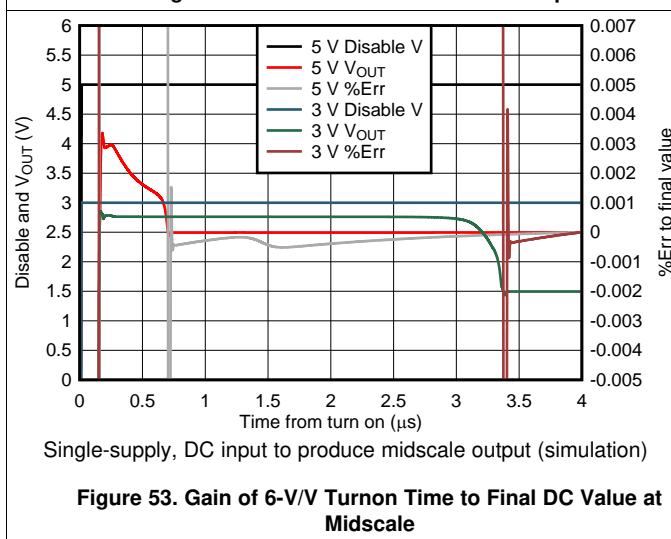
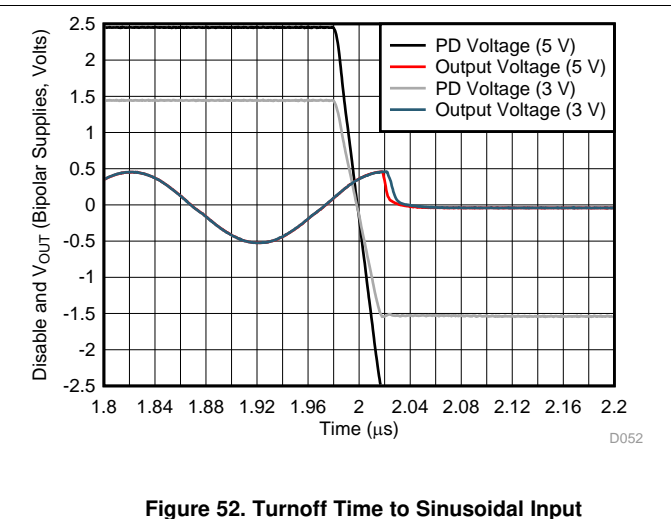
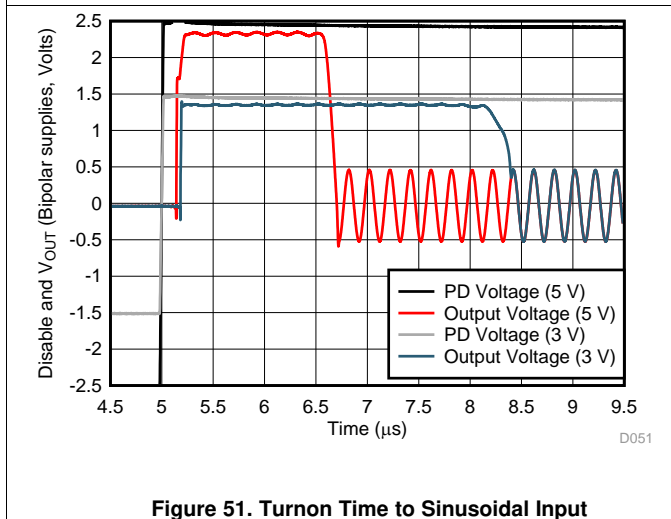
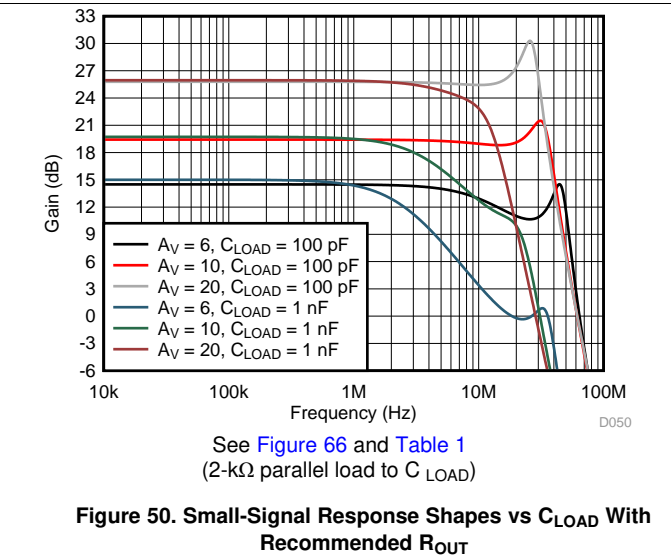
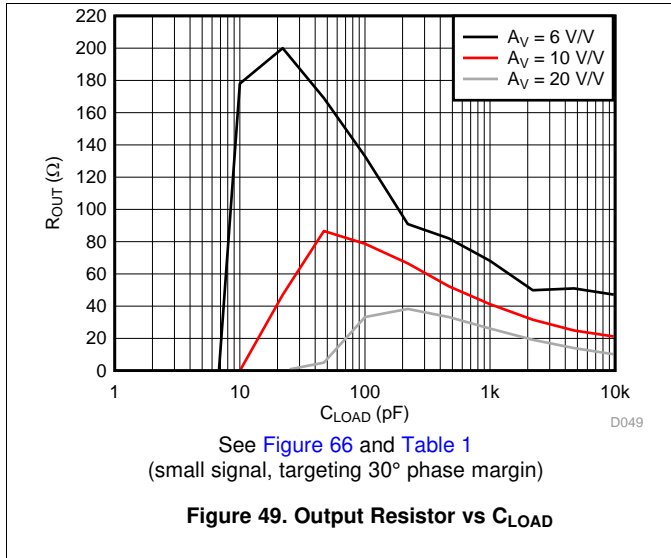
**Typical Characteristics: Over Supply Range (continued)**

$\overline{PD} = V_{S+}$  and  $T_A = 25^\circ\text{C}$  (unless otherwise noted)



Typical Characteristics: Over Supply Range (continued)

$\overline{PD} = V_{S+}$  and  $T_A = 25^\circ\text{C}$  (unless otherwise noted)



Typical Characteristics: Over Supply Range (continued)

$\overline{PD} = V_{S+}$  and  $T_A = 25^\circ\text{C}$  (unless otherwise noted)

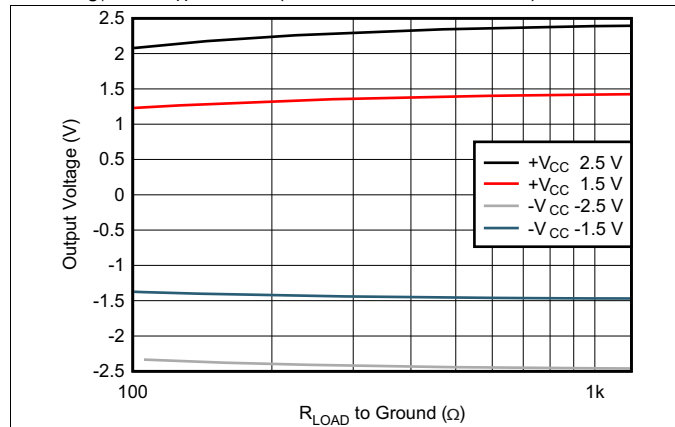


Figure 55. Output Voltage Swing vs Load Resistor

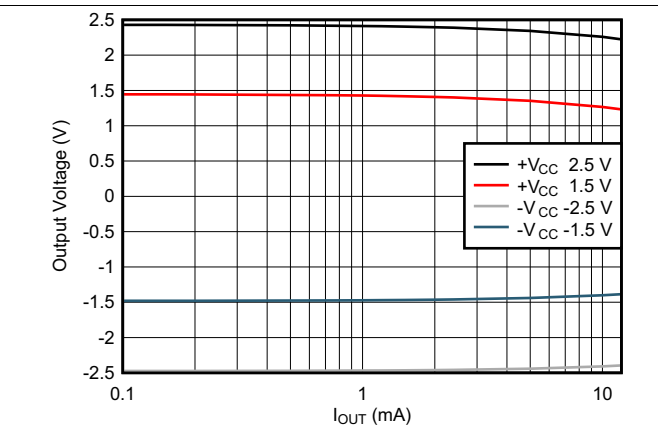


Figure 56. Output Saturation Voltage vs Load Current

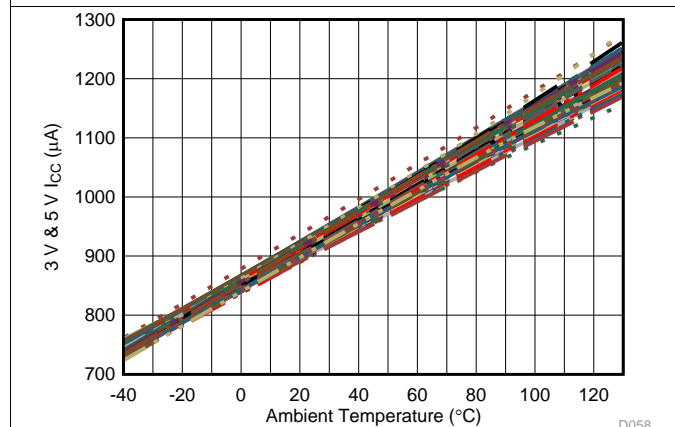


Figure 57. Quiescent Current vs Temperature

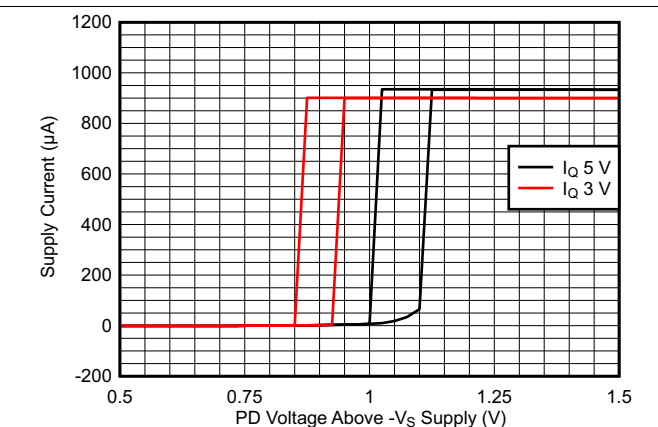


Figure 58. Supply Current vs Power-Down Voltage: Turnon Higher Than Turnoff

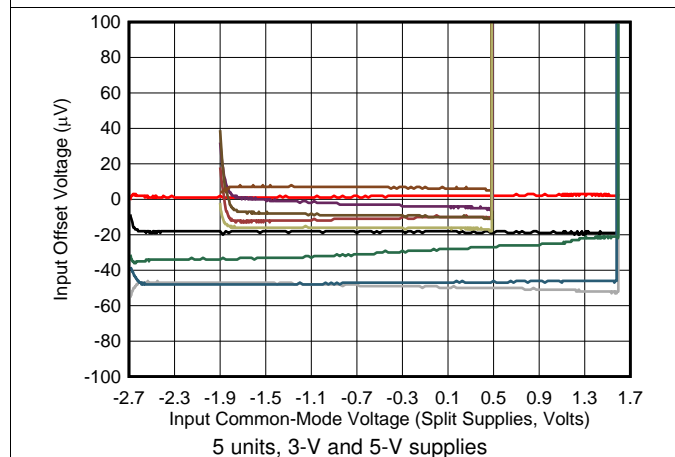


Figure 59. Input Offset Voltage vs Input Common-Mode Voltage

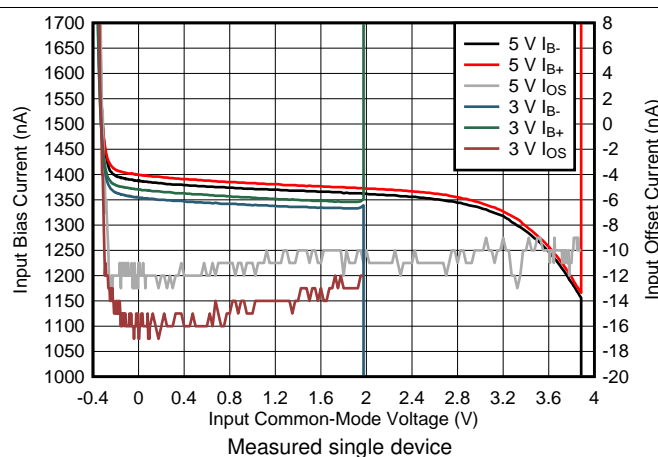


Figure 60. Input Bias and Offset Current vs  $V_{ICM}$

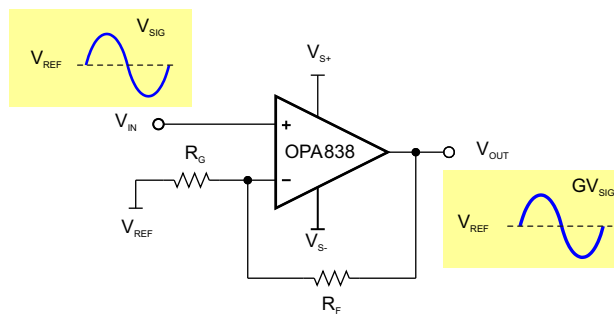
## 8 Detailed Description

### 8.1 Overview

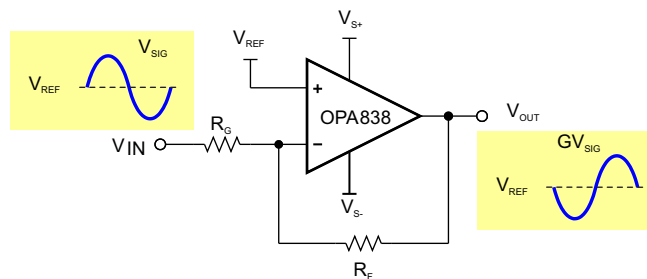
The OPA838 is a power efficient, decompensated, voltage feedback amplifier (VFA). Combining a negative rail input stage and a rail-to-rail output (RRO) stage, the device provides a flexible solution where higher gain or transimpedance designs are required. This 300-MHz gain bandwidth product (GBP) amplifier requires less than 1 mA of supply current over a 2.7 to 5.4-V total supply operating range. A shutdown feature on the 6-pin package versions provides power savings where the system requires less than 1  $\mu$ A when shut down. A decompensated amplifier operating at low gains (less than 6 V/V) may experience a low phase margin that may risk oscillation. The TINA model for the OPA838 predicts those conditions.

### 8.2 Functional Block Diagram

The OPA838 is a standard voltage feedback op amp with two high-impedance inputs and a low-impedance output. Standard applications circuits are supported; see [Figure 61](#) and [Figure 62](#). These application circuits are shown with a DC  $V_{REF}$  on the inputs that set the DC operating points for single-supply designs. The  $V_{REF}$  is often ground, especially for split-supply applications.



**Figure 61. Noninverting Amplifier**



**Figure 62. Inverting Amplifier**

### 8.3 Feature Description

#### 8.3.1 Input Common-Mode Voltage Range

When the primary design goal is a linear amplifier with high CMRR, the input pins must stay within the input operating range ( $V_{ICR}$ ). These are referenced off of each supply as an input headroom requirement. Ensured operation at 25°C is maintained to the negative supply voltage and to within 1.3 V of the positive supply voltage. The common-mode input range specifications in the table data use CMRR to set the limit. The limits are selected to ensure CMRR does not degrade more than 3 dB below the minimum CMRR value if the input voltage is within the specified range.

## Feature Description (continued)

Assuming the op amp is in linear operation, the voltage difference between the input pins is small (0 V) and the input common-mode voltage is analyzed at either input pin, assuming the other input pin is at the same potential. The voltage at  $V_{IN+}$  is simple to evaluate. In noninverting configuration (see [Figure 61](#)), the input signal ( $V_{IN}$ ) must not violate the  $V_{ICR}$ . In inverting configuration (see [Figure 62](#)), the reference voltage ( $V_{REF}$ ), must be within the  $V_{ICR}$ .

The input voltage limits have fixed headroom to the power rails and track the power supply voltages. For a single 5-V supply, the linear 25°C minimum input voltage ranges from 0 V to 3.7 V, and 0 V to 1.4 V for a single 2.7-V supply. The delta headroom from each power supply rail is the same in each case (0 V and 1.3 V).

### 8.3.2 Output Voltage Range

The OPA838 device is a rail-to-rail output op amp. Rail-to-rail output typically means that the output voltage swings to within 100 mV of the supply rails. There are different ways to specify this: one is with the output still in linear operation and another is with the output saturated. Saturated output voltages are closer to the power supply rails than linear outputs, but the signal is not a linear representation of the input. Saturation and linear operation limits are affected by the output current, where higher currents lead to more voltage loss in the output transistors; see [Figure 56](#).

The specification tables show saturated output voltage specifications with a 2-k $\Omega$  load. [Figure 11](#) and [Figure 43](#) illustrate saturated voltage-swing limits versus output load resistance, and [Figure 12](#) and [Figure 44](#) illustrate the output saturation voltage versus load current. With a light load, the output voltage limits have constant headroom to the power rails and track the power supply voltages. For example, with a 1-k $\Omega$  load and a single 5-V supply, the linear output voltage ranges from 0.12 V to 4.88 V and ranges from 0.12 V to 2.58 V for a 2.7-V supply. The delta from each power supply rail is the same in each case: 0.12 V.

With devices like the OPA838 where the input range is lower than the output range, the input limits the available signal swing at low gains. Because the OPA838 is intended for higher gains, the smaller input swing range does not limit operation and full rail-to-rail output is available. Inverting voltage gain and transimpedance configurations are typically limited by the output voltage limits of the op amp if the noninverting input pin is biased in range.

### 8.3.3 Power-Down Operation

The OPA838 includes a power-down feature. Under logic control, the amplifier can switch from normal operation to a standby current of less than 1  $\mu$ A. When the  $\overline{PD}$  pin is connected high (greater than or equal to 1.5 V above the negative supply), the amplifier is active. Connecting the  $\overline{PD}$  pin low (less than or equal to 0.55 V above the negative supply) disables the amplifier. To protect the input stage of the amplifier, the device uses internal, back-to-back diodes (two in series each way) between the inverting and noninverting input pins. If the differential voltage in shutdown exceeds 1.2 V, those diodes turn on.

The  $\overline{PD}$  pin must be actively driven high or low and must not be left floating. If the power-down mode is not used,  $\overline{PD}$  may be tied to the positive supply rail.

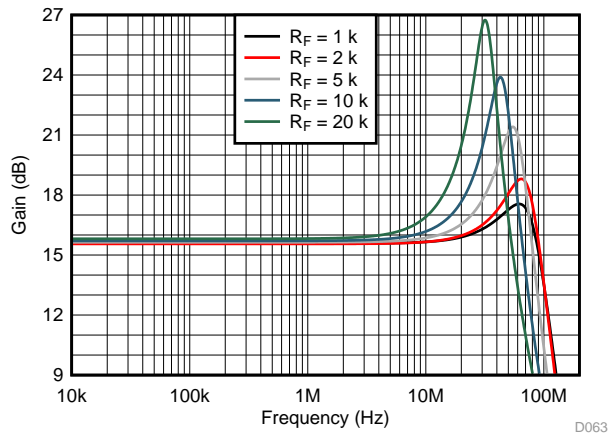
When the op amp is powered from a single-supply and ground, with  $\overline{PD}$  driven from logic devices with similar  $V_{DD}$  voltages to the op amp, no special considerations are required. When the op amp is powered from a split-supply with  $V_{S-}$  below ground, an open-collector type of interface with a pullup resistor is more appropriate. Pullup resistor values must be lower than 100 k $\Omega$ . Recovery from power down is illustrated in [Figure 53](#) and [Figure 54](#) for several gains. In single-supply mode with the gain resistor at ground, the output approaches the positive supply on initial power up until the internal nodes charge then recover to the target output voltage; see [Figure 51](#) and [Figure 52](#).

### 8.3.4 Trade-Offs in Selecting The Feedback Resistor Value

The OPA838 is specified using a 1-k $\Omega$  feedback resistor with a 200- $\Omega$  gain resistor to ground in a noninverting gain of 6 V/V configuration. These values give a good compromise, keeping the noise contribution of the resistors well below that of the amplifier noise terms and minimal power in the feedback network as the output voltage swing creates load current back into the feedback network. Decreasing these values improves the noise at the cost of more power dissipated in the feedback network. Low values increase the harmonic distortion as the feedback load decreases. Increasing the  $R_F$  value at a particular gain increases the output noise contribution of those resistors possibly becoming dominant. As the feedback resistor values continue to increase (and the  $R_G$  at

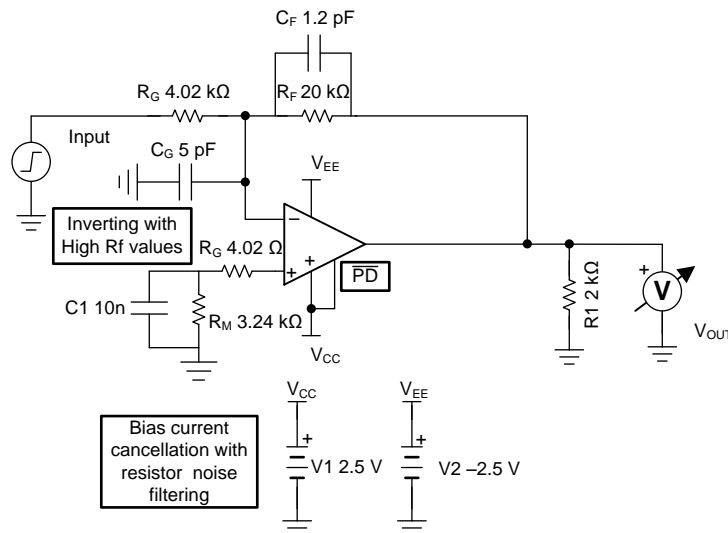
**Feature Description (continued)**

a fixed target gain), there is a loss of phase margin as the impedance that drives the inverting input capacitance brings in an added loop pole at lower frequencies. **Figure 63** shows this at a gain of 6 V/V with increasing  $R_F$  values. This noninverting test shows more peaking as the  $R_F$  values increase due to the 1-pF common-mode input capacitance at the inverting input. The TINA simulation model gives excellent prediction of these effects.



**Figure 63. Frequency Response With Various Feedback Resistor Values**

Operating the OPA838 in inverting mode with higher  $R_F$  values increases response peaking due to the loss of phase margin effect. In the inverting case, a pair of capacitors can flatten the response at the cost of lower closed-loop bandwidth. **Figure 64** shows an example with a 20-k $\Omega$   $R_F$  value at an inverting gain of  $-5$  V/V (noise gain = 6 V/V) with optional capacitors ( $C_F$  and  $C_G$ ). **Figure 64** shows optional bias current cancellation elements on the noninverting input. The total resistance value matches the parallel combination of  $R_G \parallel R_F$ , which reduces the DC output error term due to bias current to  $I_{OS} \times R_F$ . The 10-nF capacitor is added across the larger part of this bias current canceling resistance to filter noise and the 20  $\Omega$  is split out to isolate the capacitor self resonance from the noninverting input. **Figure 65** illustrates the small-signal response shape with and without these capacitors. The feedback capacitor ( $C_F$ ), is selected to set a desired closed-loop bandwidth with  $R_F$ .  $C_G$  is added to ground to shape the noise gain up over frequency to be greater than or equal to 6 V/V at higher frequencies. In this example, that higher frequency noise gain is  $1 + 6 / 1.2 = 6$  V/V, adding the 1-pF device common-mode capacitance to the external 5 pF. Using the capacitors to set the feedback ratio removes the pole produced in the feedback driving from purely resistive source to the inverting parasitic capacitance.



**Figure 64.  $G = -5$  V/V With Optional Compensation**

Feature Description (continued)

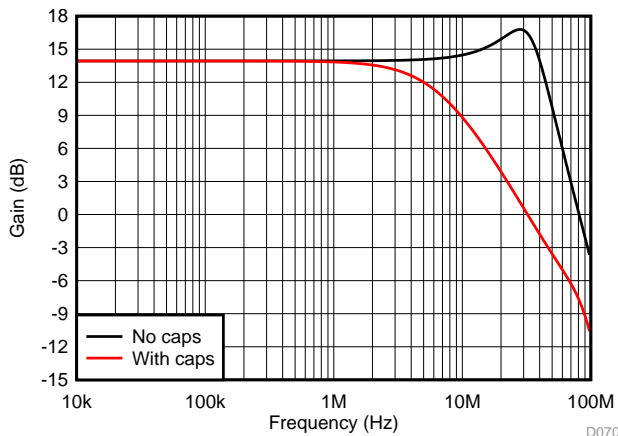


Figure 65. Inverting Response With and Without Compensation

8.3.5 Driving Capacitive Loads

The OPA838 can drive small capacitive loads directly without oscillation (less than 6 pF). When driving capacitive loads greater than 6 pF, Figure 49 illustrates the recommended  $R_{OUT}$  vs capacitor load parametric on gains. At higher gains, the amplifier starts with greater phase margin into a resistive load and can operate with lower  $R_{OUT}$  for a given capacitive load. Without  $R_{OUT}$ , output capacitance interacts with the output impedance of the amplifier, which causes phase shift in the loop gain of the amplifier that reduces the phase margin. This causes peaking in the frequency response with overshoot and ringing in the pulse response. Figure 49 targets a 30° phase margin for the OPA838. A 30° phase margin produces a 5.7-dB peaking in the frequency response at the amplifier output pin that is rolled off by the output RC pole; see Figure 67. This peaking can cause clipping for large signals driving a capacitive load. Increasing the  $R_{OUT}$  value can reduce the peaking at the cost of a more band-limited overall response.

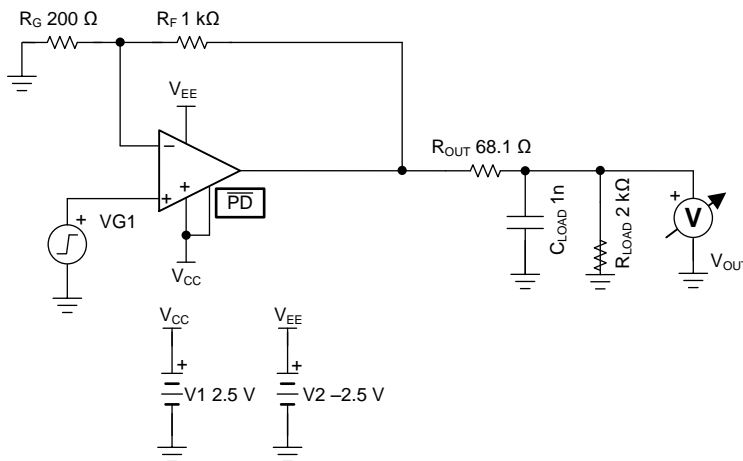


Figure 66.  $R_{OUT}$  versus  $C_L$  Test Circuit

## Feature Description (continued)

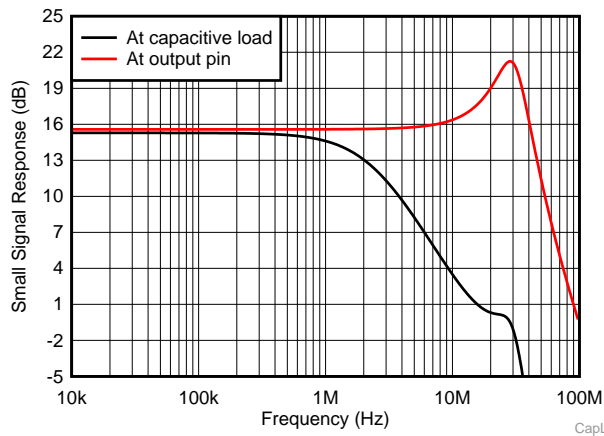


Figure 67. Frequency Response to Output Pin and Capacitive Load

## 8.4 Device Functional Modes

### 8.4.1 Split-Supply Operation ( $\pm 1.35\text{ V}$ to $\pm 2.7\text{ V}$ )

To facilitate testing with common lab equipment, the OPA838 EVM (see EVM board link) is built to allow split-supply operation. This configuration eases lab testing because the midpoint between the power rails is ground, and most signal generators, network analyzers, oscilloscopes, spectrum analyzers, and other lab equipment have inputs and outputs with a ground reference. This simplifies characterization by removing the requirement for blocking capacitors.

Figure 68 shows a simple noninverting configuration analogous to Figure 61 with a  $\pm 2.5\text{-V}$  supply and  $V_{REF}$  equal to ground. The input and output swing symmetrically around ground. For ease of use, split-supplies are preferred in systems where signals swing around ground. Using bipolar (or split) supplies shifts the thresholds for the shutdown control. The disable control is referenced from the negative supply. Typically, this is ground in a single-supply application, but using a negative supply requires that the pin is set to within  $0.55\text{ V}$  above the negative supply to disable. If disable is not required, connecting that pin to the positive supply ensures correct operation, even for split-supply applications. This disable pin cannot be floated but must be asserted to a voltage.

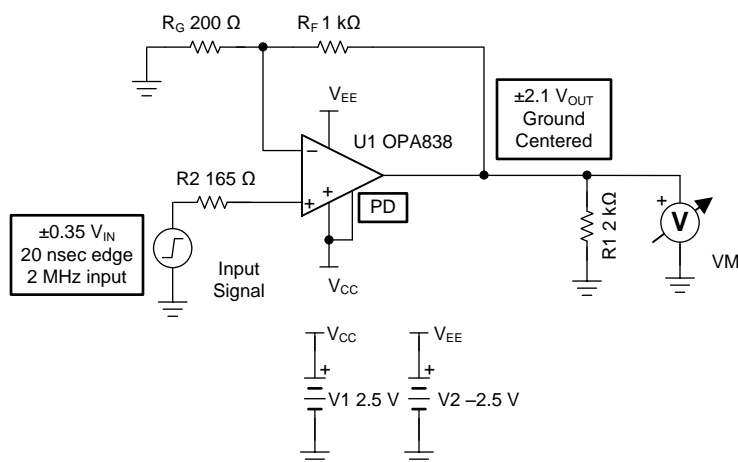


Figure 68. Split-Supply Operation



Device Functional Modes (continued)

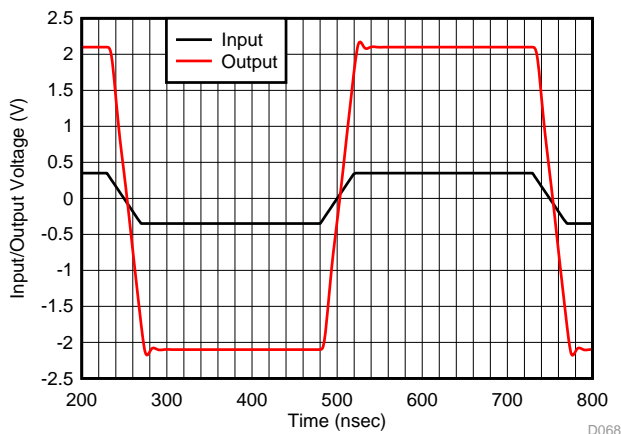


Figure 69. Bipolar-Supply Step Response

8.4.2 Single-Supply Operation (2.7 V to 5.4 V)

Most newer systems use a single power supply to improve efficiency and to simplify power supply design. The OPA838 can be used with single-supply power (ground for the negative supply) with no change in performance from split supply, as long as the input and output pins are biased within the linear operating region of the device. The outputs nominally swing rail-to-rail with approximately a 100-mV headroom required for linear operation. The inputs can swing below the negative rail (typically ground) and to within 1.3 V of the positive supply. For DC-coupled single-supply operation, the higher gain operating applications typical of a decompensated op amp keep the input swings below the input swing limit to the positive supply. Typically, the 1.3-V input headroom required to the positive supply does not limit operation.

Figure 70 shows an example design taking a 0 V to 0.5 V input range, level shifting the output up to 0.15 V for a 0-V input using the 4.5-V reference voltage common for 5-V SAR ADCs, and sets the gain to produce a 4.1-V output swing for the 0.5-V input swing. This example is assuming a 0-Ω source that is required to sink the 39 μA required to bias the positive input pin to produce the 0.15-V output for 0-V input. The R<sub>F</sub> and R<sub>G</sub> values are scaled down slightly to provide bias current cancellation by matching the parallel combination of the two bias set-up resistors on the noninverting input. Figure 71 illustrates an example step response for this circuit that produces an output from 0.15 V for a 0-V input to 4.35 V for a 0.5-V input.

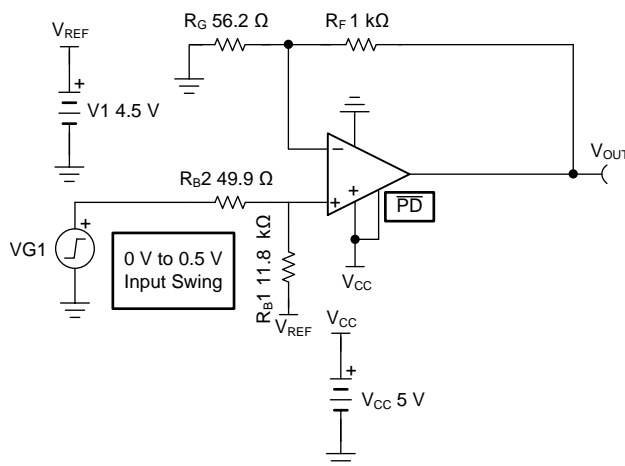


Figure 70. DC-Coupled, Single-Supply, Noninverting Interface With Output Level Shift

Device Functional Modes (continued)

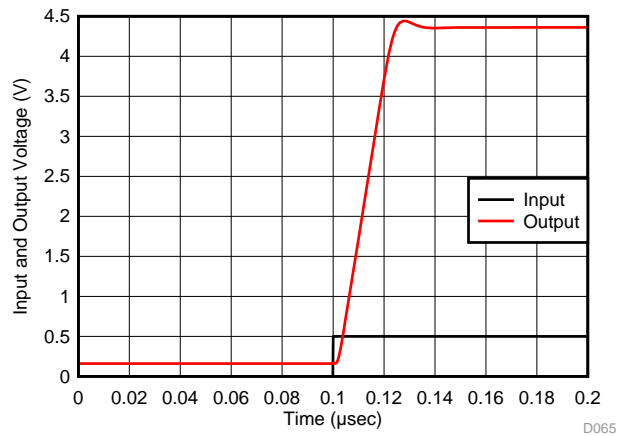


Figure 71. Unipolar Input to Level Shifted Output Step Response

If AC-coupling is acceptable, a simple way to operate single-supply is to run inverting. Figure 72 shows a low-power, high-gain example. In this example, a gain of  $-20$  V/V is implemented (inverting usually does not matter for AC-coupled channels) where the  $V_+$  input is biased midscale. This example is showing an optional bias current cancellation setup, which may not be necessary unless the output DC level requires good accuracy. The parallel combination of the divider resistors plus the  $80.7\text{-}\Omega$  isolating resistor match the feedback resistor value. With the blocking capacitor at the inverting input, the feedback resistor impedance must be matched to achieve bias current cancellation. In this 3-V supply example, the two inputs and the output are biased at 1.5 V. This places the input pins in range and centers the output for maximum  $V_{PP}$  available. Figure 73 illustrates the small-signal response for this example showing a  $F_{-3dB}$  range from a low-end cutoff of 887 Hz set by the input capacitor value to a 17.5-MHz high-frequency cutoff.

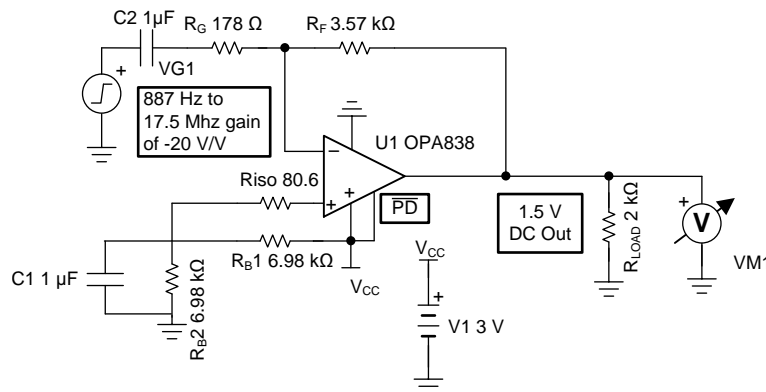


Figure 72. Single-Supply Inverting Gain Stage With AC-Coupled Input

Device Functional Modes (continued)

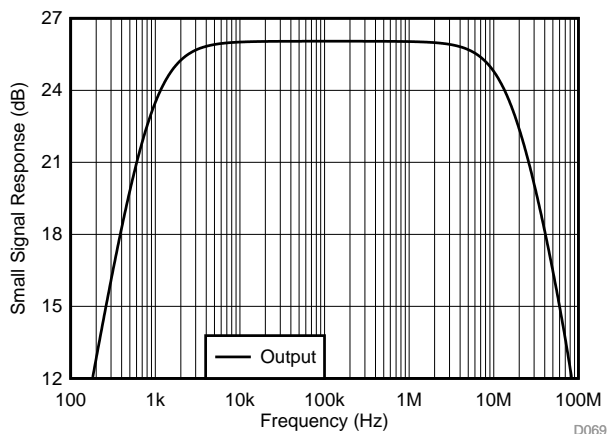


Figure 73. Inverting Single-Supply Response With AC-Coupled Input

These are only two of the many ways a single-supply design may be implemented. Many others exist where using a DC reference voltage or AC-coupling are common. A good compilation of options can be found in [Single-Supply Op Amp Design Techniques](#).

8.5 Power Shutdown Operation

As noted, the 6-pin packages that offer a power shutdown feature must have that pin asserted. To retain the lowest possible shutdown power, no internal pullup resistors are present in the OPA838. The control threshold is referenced off the negative supply with a nominal internal threshold near 1 V above the negative supply. Worst-case tolerances dictate the required low-level voltage to ensure shutdown of 0.55 V or less above the negative supply and 1.5 V or greater above the negative supply to ensure enabled operation. The required control pin current is less than  $\pm 50$  nA. For SOT-23-6 applications that do not require a shutdown functionality, connect the disable control pin to the positive supply. For SC70 package applications that do not require a shutdown, use the 5-pin package where the control pad is internally connected to the positive supply. When disabled, the output nominally goes to a high impedance. However, the feedback network provides a path for discharge for off state voltage condition. Figure 51 illustrates the turnon time with a sinusoidal input that is relatively slow, while Figure 52 illustrates the turnoff time is fast. Figure 53 and Figure 54 illustrate the single-supply operation with a DC input to produce a midsupply output at gains of 6 V/V and 10 V/V. In all cases, the output voltage transitions to a point close to the positive supply voltage and then moves to the desired output voltage 0.5  $\mu$ s to 1.5  $\mu$ s after the disable control line goes high. The supply current in shutdown is a low 0.1  $\mu$ A nominally with a maximum 1  $\mu$ A.

## 9 Application and Implementation

### NOTE

Information in the following applications sections is not part of the TI component specification, and TI does not warrant its accuracy or completeness. TI's customers are responsible for determining suitability of components for their purposes. Customers should validate and test their design implementation to confirm system functionality.

### 9.1 Application Information

#### 9.1.1 Noninverting Amplifier

The OPA838 can be used as noninverting amplifier with signal input to the noninverting input ( $V_{IN+}$ ). Figure 61 illustrates a basic block diagram of the circuit.  $V_{REF}$  is often ground when split supplies are used.

If  $V_{IN} = V_{REF} + V_{SIG}$ , and the gain setting resistor ( $R_G$ ) is DC referenced to  $V_{REF}$ , use Equation 1 to calculate the output of the amplifier.

$$V_{OUT} = V_{SIG} \left( 1 + \frac{R_F}{R_G} \right) + V_{REF} \tag{1}$$

$$G = 1 + \frac{R_F}{R_G}$$

The noninverting signal gain (also called the noise gain) of the circuit is set by:

$V_{REF}$  provides a reference around which the input and output signals swing. Output signals are in-phase with the input signals within the flat portion of the frequency response. For a high-speed, low-noise device like the OPA838, the values selected for  $R_F$  (and the  $R_G$  for the desired gain) can strongly influence the operation of the circuit. For the characteristic curves, the noninverting circuit of Figure 74 shows the test configuration. Table 1 lists the recommended resistor values over gain.

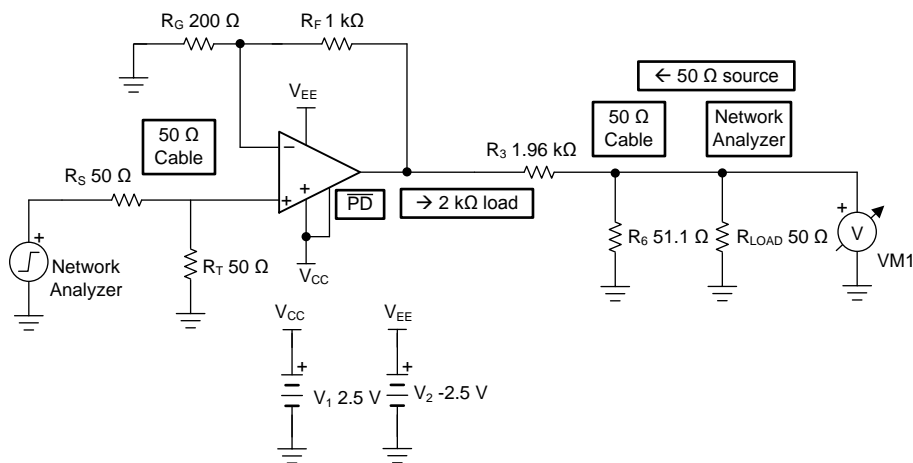


Figure 74. Noninverting Characterization Circuit

## Application Information (continued)

Table 1 lists the recommended resistor values from target gains of 6 V/V to 20 V/V. This table controls the  $R_F$  and  $R_G$  values to set the resistor noise contribution at approximately 40% of the total output noise power. This increases the spot noise at the output over what the op amp voltage noise produces by 20%. Lower values reduce the output noise of any design at the cost of more power in the feedback circuit. Using the TINA model and simulation tool shows the impact of different resistor value choices on response shape and noise.

**Table 1. Noninverting Recommended Resistor Values**

TARGET AVERAGE	$R_F$ (OHMS)	$R_G$ (OHMS)	ACTUAL GAIN (V/V)	GAIN (dB)
6	1000	200	6	15.56
7	1180	196	7.02	16.93
8	1370	196	7.99	18.05
9	1540	191	9.06	19.15
10	1690	187	10.04	20.03
11	1870	187	11	20.83
12	2050	187	11.96	21.56
13	2210	182	13.14	22.37
14	2370	182	14.02	22.94
15	2550	182	15.01	23.53
16	2740	182	16.05	24.11
17	2870	178	17.12	24.67
18	3090	182	17.98	25.09
19	3240	178	19.20	25.67
20	3400	178	20.1	26.06
21	3570	178	21.06	26.47

### 9.1.2 Inverting Amplifier

The OPA838 can be used as an inverting amplifier with signal input to the inverting input ( $V_{IN-}$ ) through the gain-setting resistor ( $R_G$ .) Figure 62 illustrates a basic block diagram of the circuit.

If  $V_{IN} = V_{REF} + V_{SIG}$ , and the noninverting input is DC biased to  $V_{REF}$ , the output of the amplifier may be calculated according to Equation 2.

$$V_{OUT} = V_{SIG} \left( \frac{-R_F}{R_G} \right) + V_{REF} \quad (2)$$

The signal gain of the circuit  $G = \frac{-R_F}{R_G}$  and  $V_{REF}$  provides a reference point around which the input and output signals swing. For bipolar-supply operation,  $V_{REF}$  is often GND. The output signal is 180° out-of-phase with the input signal in the passband of the application. Figure 75 illustrates the 50-Ω input matched configuration used for the inverting characterization plots. In this case, an added termination resistor is placed in parallel with the input  $R_G$  resistor to provide an impedance match to 50-Ω test equipment. Table 2 lists the suggested values for  $R_F$ ,  $R_G$ , and  $R_T$  for inverting gains from –6 V/V to –20 V/V.

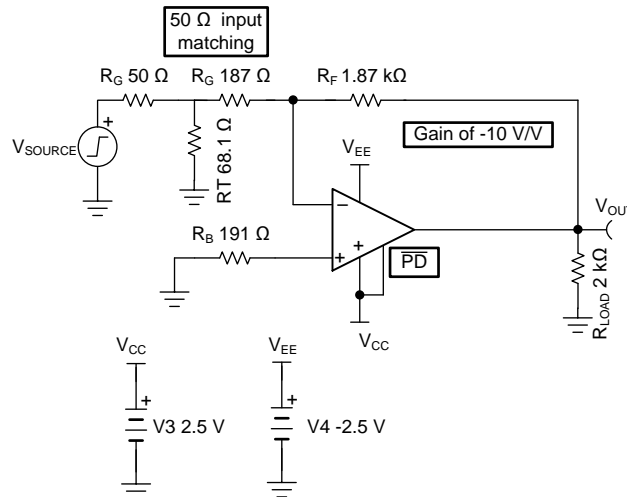


Figure 75. Inverting With Input Impedance Matching

Table 2. Inverting Recommended Resistor Values

AVERAGE	R <sub>F</sub> (OHMS)	R <sub>G</sub> (OHMS)	EXACT R <sub>T</sub>	STANDARD R <sub>T</sub>	INPUT Z <sub>I</sub>	ACTUAL (V/V)	GAIN (dB)
-6	1180	196	67.1	66.5	49.7	-6.02	15.59
-7	1370	196	67.1	66.5	49.7	-6.99	16.89
-8	1540	191	67.7	68.1	50.2	-8.06	18.13
-9	1690	187	68.2	68.1	49.9	-9.04	19.12
-10	1870	187	68.2	68.1	49.9	-10	20
-11	2050	187	68.2	68.1	49.9	-10.96	20.80
-12	2210	182	68.9	68.1	49.6	-12.14	21.69
-13	2370	182	68.9	68.1	49.6	-13.02	22.29
-14	2550	182	68.9	68.1	49.6	-14.01	22.93
-15	2740	182	68.9	68.1	49.6	-15.05	23.55
-16	2870	178	69.5	69.8	50.1	-16.12	24.15
-17	3090	182	68.9	69.8	50.5	-16.98	24.6
-18	3240	178	69.5	69.8	50.1	-18.20	25.2
-19	3400	178	69.5	69.8	50.1	-19.10	25.62
-20	3570	178	69.5	69.8	50.1	-20.06	26.04

### 9.1.3 Output DC Error Calculations

The OPA838 can provide excellent DC signal accuracy due to high open-loop gain, high common-mode rejection, high power-supply rejection, and low input offset voltage and bias current offset errors. To take full advantage of this low input offset voltage, pay careful attention to input bias current cancellation. The low-noise input stage for the OPA838 has a relatively high input bias current (1.6  $\mu$ A typical out the pins) but with a close match between the two input currents. This is a negative rail input device using PNP input devices where the base current flows out of the device pins. A large resistor to ground on the V+ input shifts positively because of the input bias current. The mismatch between the two input bias currents is very low, typically only  $\pm 20$  nA of input offset current. Match the DC source impedances out of the two inputs to reduce the total output offset voltage. For example, one way to add bias current cancellation to the circuit in [Figure 68](#) is to insert a 165- $\Omega$  series resistor into the noninverting input to match the parallel combination of R<sub>F</sub> and R<sub>G</sub> for this basic gain of

6 V/V noninverting gain circuit. These same calculations apply to the output offset drift. Analyzing the simple circuit of Figure 68, the noise gain for the input offset voltage drift is  $1 + 1k / 200 = 6$  V/V. This results in an output drift term of  $\pm 1.6 \mu\text{V}/^\circ\text{C} \times 6 = \pm 9.6 \mu\text{V}/^\circ\text{C}$ . Because the two impedances out of the inputs are matched, the residual error due to the maximum  $\pm 500 \text{ pA}/^\circ\text{C}$  offset current drift is exactly that number times the 1-k $\Omega$  feedback resistor value, or  $\pm 50 \mu\text{V}/^\circ\text{C}$ . The total output DC error drift band is  $\pm 59 \mu\text{V}/^\circ\text{C}$ .

### 9.1.4 Output Noise Calculations

The decompensated voltage feedback of the OPA838 op amp offers among the lowest input voltage and current noise terms for any device with a supply current less than 1 mA. Figure 76 shows the op amp noise analysis model that includes all noise terms. In this model, all the noise terms are shown as noise voltage or current density terms in  $\text{nV}/\sqrt{\text{Hz}}$  or  $\text{pA}/\sqrt{\text{Hz}}$ .

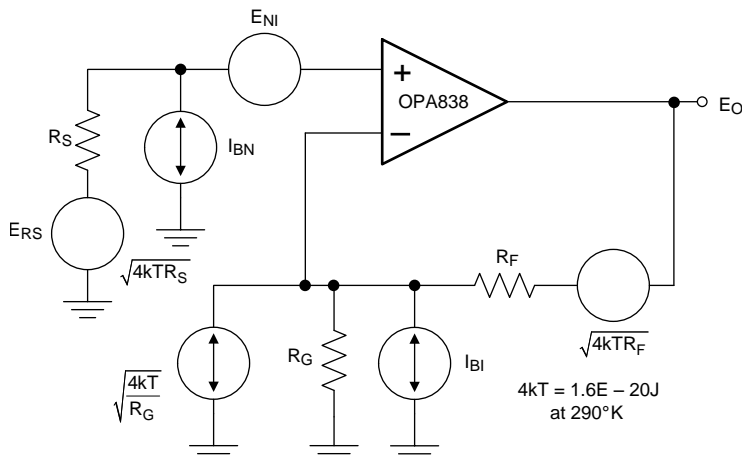


Figure 76. Op Amp Noise Analysis Model

The total output spot noise voltage is computed as the square root of the squared contributing terms to the output noise voltage. This computation is adding all the contributing noise powers at the output by superposition, then taking the square root to return to a spot noise voltage. Equation 3 shows the general form for this output noise voltage using the terms presented in Figure 76.

$$E_O = \sqrt{\left[ E_{NI}^2 + (I_{BN}R_S) + 4kTR_S \right] NG^2 + (I_{BI}R_F)^2 + 4kTR_F NG} \quad (3)$$

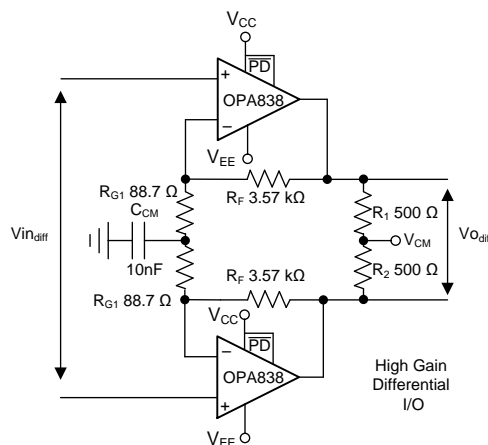
Dividing this expression by the noise gain ( $NG = 1 + R_F / R_G$ ) gives the equivalent input referred spot noise voltage at the noninverting input, as shown in Equation 4.

$$E_N = \sqrt{E_{Ni}^2 + (I_{BN}R_S)^2 + 4kTR_S + \left(\frac{I_{BI}R_F}{NG}\right)^2 + \frac{4kTR_F}{NG}} \quad (4)$$

Using the resistor values shown in Table 1 with  $R_S = 0 \Omega$  results in a constant input referred voltage noise of  $2.86\text{nV} / \sqrt{\text{Hz}}$ . Reducing the resistor values brings this number closer to the intrinsic  $1.9 \text{ nV} / \sqrt{\text{Hz}}$  of the OPA838. Adding  $R_S$  for bias current cancellation in noninverting mode adds the noise from  $R_S$  to the total output noise, as shown in Equation 3. In inverting mode, the  $R_S$  bias current cancellation resistor must be bypassed with a capacitor for the best noise performance.

### 9.1.5 High-Gain Differential I/O Designs

A high-gain differential-to-differential I/O circuit can be used to drive a second-stage FDA or a differential-to-single-ended stage. This circuit is frequently used in applications where high input impedance is required (for example, if the source cannot be loaded). Figure 76 illustrates an example design where the differential gain is 41 V/V. An added element between the two  $R_G$  resistors increases the noise gain for the common-mode feedback. It is important to provision for the added element because a decompensated VFA (like the OPA838) often oscillates without it in this circuit. With only the  $R_G$  elements in the differential I/O design, the common-mode feedback is unity-gain and often causes high-frequency, common-mode oscillations. To resolve this issue, split the  $R_G$  elements in half and add a low-impedance path such as a capacitor or a DC reference between the two  $R_G$  values.



**Figure 77. High-Gain Differential I/O Stage**

Integrated results are available, but the OPA838 device provides a low-power, high-frequency result. For best CMRR performance, resistors must be matched. A good rule is  $CMRR \approx$  the resistor tolerance; so 0.1% tolerance provides approximately 60-dB CMRR.

#### 9.1.5.1 Differential I/O Design Requirements

As an example design, start with the circuit in Figure 77.

- Set the target gain and split the  $R_G$  element in half. For this example, target a gain of 41 V/V.
- Assess the DC common-mode biasing on the noninverting inputs. The DC biasing must be in range and have a gain of 1 to the output. This is not illustrated in Figure 76.
- If a DC reference is used as the mid- $R_G$  bias, setting the reference equal to the noninverting input bias voltage sets the output common-mode to that voltage. Using a capacitor as illustrated in Figure 76 accomplishes the same results.

#### 9.1.5.2 Detailed Design Procedure

- Set the total  $R_G$  value near the high gain values using Table 1. This 178- $\Omega$  total must be split for a center tap to increase the common-mode noise gain, as shown by the 88.7- $\Omega$  value in Figure 77.
- Set  $R_F$  using a standard value near the calculated from solving Equation 1 using half of the total  $R_G$  value.



- Simulate the common-mode noise with different elements on the  $R_G$  center tap, as shown in Figure 78. Decide which is most appropriate to the application.

The common-mode loop instability without the  $R_G$  center tap is not often apparent in the closed-loop differential simulations. It can often be detected in a common-mode output noise simulation as Figure 78 shows. Grounding the inputs Figure 77 and running a output noise simulation for the common-mode tap point in Figure 76 shows a peaking in the noise at high frequency. This peaking indicates low-phase margin for the common-mode loop. Figure 78 shows this peaking in the lowest noise curve, with two options for improving phase margin. The first option used in Figure 77 is a capacitor to ground set to increase the common-mode noise gain only at higher frequencies. This can be seen by the peaking in the common-mode noise of Figure 78. Another alternative is to provide a DC voltage reference on the  $R_G$  center tap. This raises the common-mode noise gain from DC on up in frequency. Neither of these latter two show any evidence of low phase margin peaking. They do increase the output common-mode noise significantly at lower frequencies. Typically, an increase in output common-mode noise is more acceptable than low-phase margin as the next stage (FDA, ADC, differential to single stage) rejects common-mode noise.

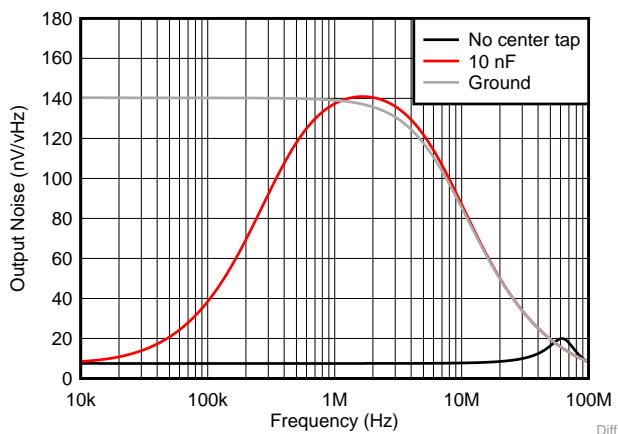


Figure 78. Common-Mode Output Noise for Differential I/O Design

Using the 10-nF center tap capacitor, Figure 79 shows the differential I/O small-signal response showing the expected  $300 \text{ MHz} / 41 \approx 7.3 \text{ MHz}$  closed-loop bandwidth. The capacitor to ground between the  $R_G$  elements does not impact the differential frequency response.

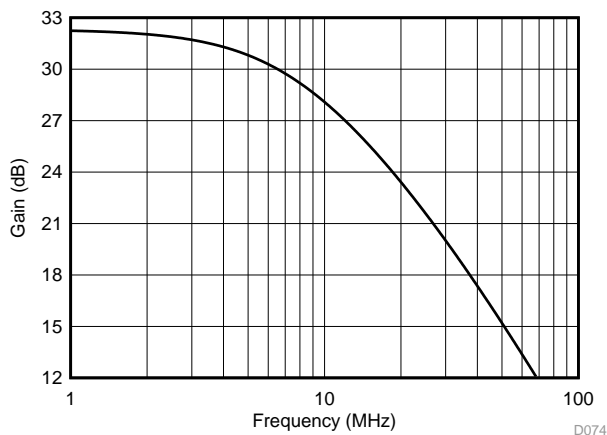
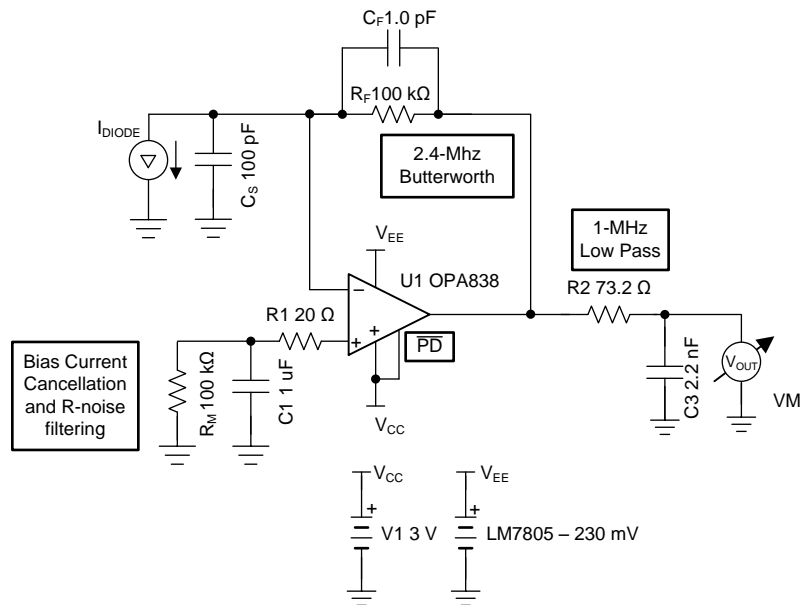


Figure 79. Differential Small-Signal Frequency Response

### 9.1.6 Transimpedance Amplifiers

A common application for a high gain bandwidth voltage feedback op amp is to amplify a small photo-diode current from a capacitive detector. Figure 80 shows the front page transimpedance circuit with more detail. Here, a fixed  $-0.23$  negative voltage generator (LM7705) is used on the negative supply to ensure the output has adequate headroom when it is at  $0$  V. The transimpedance stage is designed here for a  $2.4$  MHz flat (Butterworth) response while a simple RC post-filter band-limits the broadband noise and sets the overall bandwidth to  $1$  MHz. The requirements for a high dynamic range transimpedance (or charge) amplifier include the very low input voltage noise intrinsic to a decompensated device like the OPA838. The noise gain over frequency for this type of circuit starts out at unity gain then begins to peak with a single zero response due to the pole formed in the feedback by the feedback resistor and the total capacitance on the inverting input. That noise gain response is flattened out at higher frequencies by the feedback capacitor value to be the  $1 + C_S/C_F$  capacitor ratio. This is normally a very high noise gain allowing the decompensated OPA838 to be applied to this application. Since the noise gain is intentionally peaked to a high value in this application, the very low input voltage noise ( $1.8$  nV/ $\sqrt{\text{Hz}}$ ) of the OPA838 improves dynamic range.



**Figure 80. 100-kΩ Wide Bandwidth Transimpedance Design**

### 9.1.7 Design Requirements

To implement a controlled frequency response transimpedance design, set the transimpedance stage amplifier bandwidth higher than a controlled post RC filter. This allows variation in the source capacitance and amplifier gain bandwidth product with less overall bandwidth variation to the final output. In this example design:

- Assume a nominal source capacitance value of 100 pF. This normally comes from the capacitance versus reverse bias plot for the photodiode. No reverse bias is illustrated in [Figure 81](#), but the current source is typically a back biased diode with a negative supply on the anode and the cathode connected to the op amp inverting input. In this polarity, the signal current sinks into the diode and raises the op amp output voltage above ground.
- For the best DC precision, add a matching resistor on the noninverting input to reduce the input bias current error to  $I_{OS} \times R_F$ . This resistor adds to the input voltage noise; TI recommends bypassing that resistor with as large as a capacitor as required to roll off resistor noise. This capacitor has a relatively low frequency self resonance that interacts with the input stage and might impair stability. Add a small series 20-Ω resistor from the capacitor into the noninverting input to de-Q the resonant source impedance without adding too much noise.
- Set the feedback capacitor to achieve the desired frequency response shape.
- Add a post RC filter to control the overall bandwidth to 1 MHz. In this example, a 2.2-nF capacitor allows a low 73.2-Ω series resistor. When driving a sampling ADC (like a SAR), this combination helps reduce the sampling glitch and speed settling time.

#### 9.1.7.1 Detailed Design Procedure

The primary design requirement is to set the achievable transimpedance gain and compensate the operational amplifier with  $C_F$  for the desired response shape. A detailed transimpedance design methodology is available in [Transimpedance Considerations for High-Speed Amplifiers](#). With a source capacitance set and the amplifier selected to provide a particular gain bandwidth product, the achievable transimpedance gain and resulting Butterworth bandwidth are tightly coupled as [Equation 5](#) illustrates. Use [Equation 6](#) to solve for a maximum  $R_F$  value. When the  $R_F$  is selected, the feedback pole is set by [Equation 7](#) to be at .707 of the characteristic frequency. At that compensation point, the closed-loop bandwidth is that characteristic frequency with a Butterworth response.

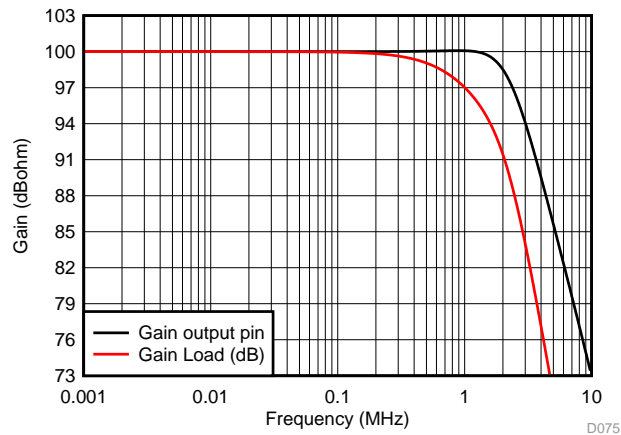
- With the 100-pF source capacitance, 300-MHz gain bandwidth product, and the 2.2-MHz closed-loop bandwidth target in the transimpedance stage, solve [Equation 6](#) for a maximum gain of 100 kΩ.
- Set the feedback pole at 0.707 times that 2.2-MHz Butterworth bandwidth. This sets the target  $1 / (2\pi \times R_F \times C_F) = 1.55$  MHz. Solving for  $C_F$  sets the target to 1 pF
- If DC precision is desired, add a 100-kΩ resistor to ground on the noninverting input. If DC precision is not required, ground the noninverting input
- Add a resistor noise filtering capacitor in parallel with the 100-kΩ resistor.
- Add a small series resistor isolating this capacitor from the noninverting input.
- Select a final filter capacitor for the load. (In this example, a value of 2.2 nF is used as a typical SAR input capacitor.)
- Add a series resistor to the final filter capacitor to form a 1-MHz pole. In this example, that is 73.2 Ω.
- Confirm this resistor is greater than the minimum recommended value illustrated in [Figure 49](#).

$$F_{-3dB} \approx \sqrt{\frac{GBP}{2\pi R_f C_S}} \quad (5)$$

$$R_{f\max} \approx \frac{GBP}{F_{-3dB}^2 2\pi C_S} \quad (6)$$

$$\frac{1}{2\pi R_f C_f} = 0.707 \times \sqrt{\frac{GBP}{2\pi R_f C_S}} \quad (7)$$

Implementing this design and simulating the performance using the TINA model for the response to the output pin and to the final capacitive load shows the expected results of [Figure 81](#). Here the exact 2.2-MHz flat Butterworth response to the output pin is shown with the final single pole rolloff at 1 MHz at the final 2.2-nF capacitor.



**Figure 81. Small-Signal Response for 100-k $\Omega$  Transimpedance Gain**

## 10 Power Supply Recommendations

The OPA838 device is intended to work in a supply range of 2.7 V to 5.4 V. Good power-supply bypassing is required. Minimize the distance (less than 0.1 inch) from the power-supply pins to high-frequency, 0.1- $\mu$ F decoupling capacitors. A larger capacitor (2.2  $\mu$ F is typical) is used with a high-frequency, 0.1- $\mu$ F supply-decoupling capacitor at the device supply pins. For single-supply operation, only the positive supply has these capacitors. When a split-supply is used, use these capacitors for each supply to ground. If necessary, place the larger capacitors further from the device and share these capacitors among several devices in the same area of the PCB. Avoid narrow power and ground traces to minimize inductance between the pins and the decoupling capacitors. An optional 0.1- $\mu$ F supply decoupling capacitor across the two power supplies (for bipolar operation) reduces second harmonic distortion.

The OPA838 has a positive supply current temperature coefficient; see [Figure 57](#). This helps improve the input offset voltage drift. Supply current requirements in system design must account for this effect using the maximum intended ambient and [Figure 57](#) to size the supply required. The very low power dissipation for the OPA838 typically does not require any special thermal design considerations. For the extreme case of 125°C operating ambient, use the approximate maximum 200°C/W for the three packages, and a maximum internal power of 5.4-V supply  $\times$  1.25-mA 125°C supply current from [Figure 57](#) gives a maximum internal power of 6.75 mW. This only gives a 1.35°C rise from ambient to junction temperature which is well below the maximum 150°C junction temperature. Load power adds to this, but also increases the junction temperature only slightly over ambient temperature.

## 11 Layout

### 11.1 Layout Guidelines

The *OPA838 EVM* can be used as a reference when designing the circuit board. TI recommends following the EVM layout of the external components near to the amplifier, ground plane construction, and power routing as closely as possible. General guidelines are listed below:

1. Signal routing must be direct and as short as possible into and out of the op amp.
2. The feedback path must be short and direct avoiding vias if possible.
3. Ground or power planes must be removed from directly under the negative input and output pins of the amplifier.
4. TI recommends placing a series output resistor as close to the output pin as possible when driving capacitive or matched loads.
5. A 2.2- $\mu$ F power-supply decoupling capacitor must be placed within two inches of the device and can be shared with other op amps. For split-supply operation, a capacitor is required for both supplies.
6. A 0.1- $\mu$ F power-supply decoupling capacitor must be placed as close to the supply pins as possible, preferably within 0.1 inch. For split-supply operation, a capacitor is required for both supplies.
7. The  $\overline{\text{PD}}$  pin uses logic levels referenced off the negative supply. If the pin is not used, the pin must tie to the positive supply to enable the amplifier. If the pin is used, the pin must be actively driven. A bypass capacitor is not necessary, but is used for EMI rejection in noisy environments.

### 11.2 Layout Example

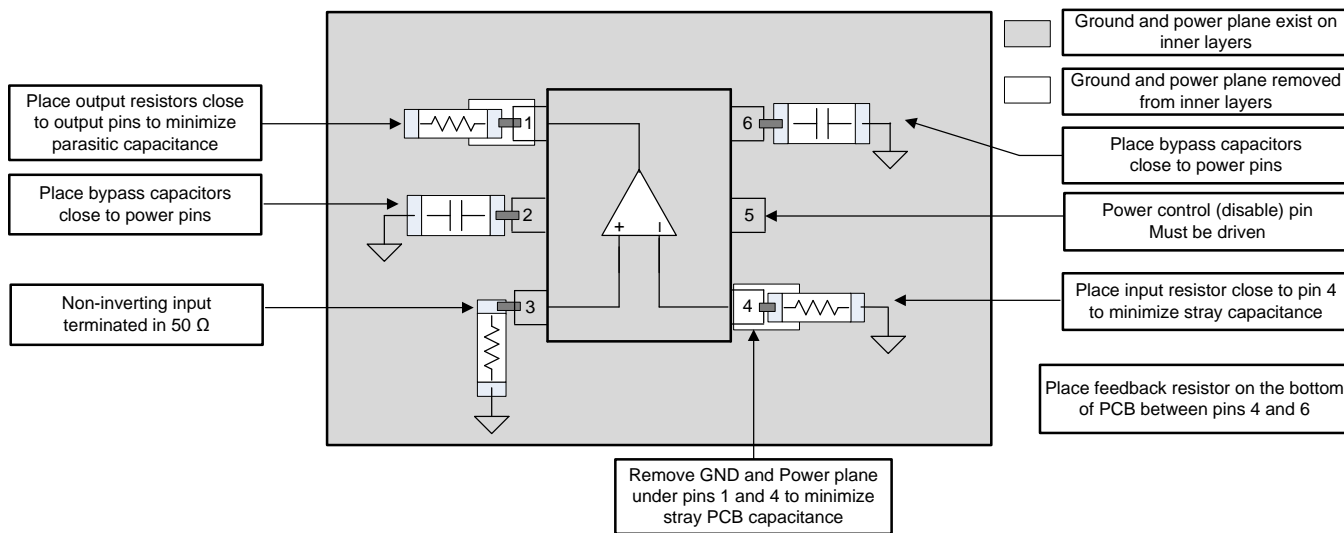


Figure 82. EVM Layout Example

## 12 Device and Documentation Support

### 12.1 Device Support

#### 12.1.1 Device Support

##### 12.1.1.1 TINA-TI™ Simulation Model Features

The device model is available on the product folder [www.ti.com](http://www.ti.com) in a typical application circuit file. The model includes numerous features intended to speed designer progress over a wide range of application requirements. The following list shows the performance parameters included in the model:

- For the small-signal response shape with any external circuit:
  - Differential Open-Loop Gain and Phase
  - Parasitic Input Capacitance
  - Open-Loop Differential Output Impedance
- For noise simulations:
  - Input Differential Spot Voltage Noise and a 100-Hz 1/f Corner
  - Input Current Noise on Each Input With a 6-kHz 1/f Corner
- For time-domain, step-response simulations:
  - Differential Slew Rate
  - I/O Headroom Models to Predict Clipping
  - Input Stage Diodes to Predict Overdrive Limiting
- Fine-scale, DC precision terms
  - PSRR
  - CMRR
  - Nominal Input Offset Voltage
  - Nominal Input Offset Current
  - Nominal Input Bias Current

The [Typical Characteristics](#) table provides more detail than the macromodels can provide. Some of the unmodeled features include:

- Harmonic Distortion
- Temperature Drift in DC Error ( $V_{IO}$  and  $I_{OS}$ )
- Overdrive Recovery Time
- Turnon and Turnoff Times Using the Power-Down Feature

### 12.2 Documentation Support

#### 12.2.1 Related Documentation

For related documentation see the following:

Texas Instruments, [OPA835DBV](#), [OPA836DBV EVM user's guide](#)

#### 12.2.2 Receiving Notification of Documentation Updates

To receive notification of documentation updates, navigate to the device product folder on [ti.com](http://ti.com). In the upper-right corner, click on *Alert me* to register and receive a weekly digest of any product information that has changed. For change details, review the revision history included in any revised document.

## Documentation Support (continued)

### 12.2.3 Community Resources

The following links connect to TI community resources. Linked contents are provided "AS IS" by the respective contributors. They do not constitute TI specifications and do not necessarily reflect TI's views; see TI's [Terms of Use](#).

**TI E2E™ Online Community** *TI's Engineer-to-Engineer (E2E) Community*. Created to foster collaboration among engineers. At [e2e.ti.com](http://e2e.ti.com), you can ask questions, share knowledge, explore ideas and help solve problems with fellow engineers.

**Design Support** *TI's Design Support* Quickly find helpful E2E forums along with design support tools and contact information for technical support.

### 12.3 Trademarks

TINA-TI, E2E are trademarks of Texas Instruments.  
All other trademarks are the property of their respective owners.

### 12.4 Electrostatic Discharge Caution



These devices have limited built-in ESD protection. The leads should be shorted together or the device placed in conductive foam during storage or handling to prevent electrostatic damage to the MOS gates.

### 12.5 Glossary

[SLYZ022](#) — *TI Glossary*.

This glossary lists and explains terms, acronyms, and definitions.

## 13 Mechanical, Packaging, and Orderable Information

The following pages include mechanical, packaging, and orderable information. This information is the most current data available for the designated devices. This data is subject to change without notice and revision of this document. For browser-based versions of this data sheet, refer to the left-hand navigation.

**PACKAGING INFORMATION**

Orderable Device	Status (1)	Package Type	Package Drawing	Pins	Package Qty	Eco Plan (2)	Lead finish/ Ball material (6)	MSL Peak Temp (3)	Op Temp (°C)	Device Marking (4/5)	Samples
OPA838IDBVR	ACTIVE	SOT-23	DBV	6	3000	RoHS & Green	NIPDAU	Level-2-260C-1 YEAR	-40 to 125	1C3F	<a href="#">Samples</a>
OPA838IDBVT	ACTIVE	SOT-23	DBV	6	250	RoHS & Green	NIPDAU	Level-2-260C-1 YEAR	-40 to 125	1C3F	<a href="#">Samples</a>
OPA838IDCKR	ACTIVE	SC70	DCK	5	3000	RoHS & Green	NIPDAU	Level-2-260C-1 YEAR	-40 to 125	17Q	<a href="#">Samples</a>
OPA838IDCKT	ACTIVE	SC70	DCK	5	250	RoHS & Green	NIPDAU	Level-2-260C-1 YEAR	-40 to 125	17Q	<a href="#">Samples</a>
OPA838SIDCKR	ACTIVE	SC70	DCK	6	3000	RoHS & Green	NIPDAU	Level-2-260C-1 YEAR	-40 to 125	19C	<a href="#">Samples</a>
OPA838SIDCKT	ACTIVE	SC70	DCK	6	250	RoHS & Green	NIPDAU	Level-2-260C-1 YEAR	-40 to 125	19C	<a href="#">Samples</a>

(1) The marketing status values are defined as follows:

**ACTIVE:** Product device recommended for new designs.

**LIFEBUY:** TI has announced that the device will be discontinued, and a lifetime-buy period is in effect.

**NRND:** Not recommended for new designs. Device is in production to support existing customers, but TI does not recommend using this part in a new design.

**PREVIEW:** Device has been announced but is not in production. Samples may or may not be available.

**OBSOLETE:** TI has discontinued the production of the device.

(2) **RoHS:** TI defines "RoHS" to mean semiconductor products that are compliant with the current EU RoHS requirements for all 10 RoHS substances, including the requirement that RoHS substance do not exceed 0.1% by weight in homogeneous materials. Where designed to be soldered at high temperatures, "RoHS" products are suitable for use in specified lead-free processes. TI may reference these types of products as "Pb-Free".

**RoHS Exempt:** TI defines "RoHS Exempt" to mean products that contain lead but are compliant with EU RoHS pursuant to a specific EU RoHS exemption.

**Green:** TI defines "Green" to mean the content of Chlorine (Cl) and Bromine (Br) based flame retardants meet JS709B low halogen requirements of <=1000ppm threshold. Antimony trioxide based flame retardants must also meet the <=1000ppm threshold requirement.

(3) MSL, Peak Temp. - The Moisture Sensitivity Level rating according to the JEDEC industry standard classifications, and peak solder temperature.

(4) There may be additional marking, which relates to the logo, the lot trace code information, or the environmental category on the device.

(5) Multiple Device Markings will be inside parentheses. Only one Device Marking contained in parentheses and separated by a "~" will appear on a device. If a line is indented then it is a continuation of the previous line and the two combined represent the entire Device Marking for that device.

(6) Lead finish/Ball material - Orderable Devices may have multiple material finish options. Finish options are separated by a vertical ruled line. Lead finish/Ball material values may wrap to two lines if the finish value exceeds the maximum column width.



**Important Information and Disclaimer:** The information provided on this page represents TI's knowledge and belief as of the date that it is provided. TI bases its knowledge and belief on information provided by third parties, and makes no representation or warranty as to the accuracy of such information. Efforts are underway to better integrate information from third parties. TI has taken and continues to take reasonable steps to provide representative and accurate information but may not have conducted destructive testing or chemical analysis on incoming materials and chemicals. TI and TI suppliers consider certain information to be proprietary, and thus CAS numbers and other limited information may not be available for release.

In no event shall TI's liability arising out of such information exceed the total purchase price of the TI part(s) at issue in this document sold by TI to Customer on an annual basis.

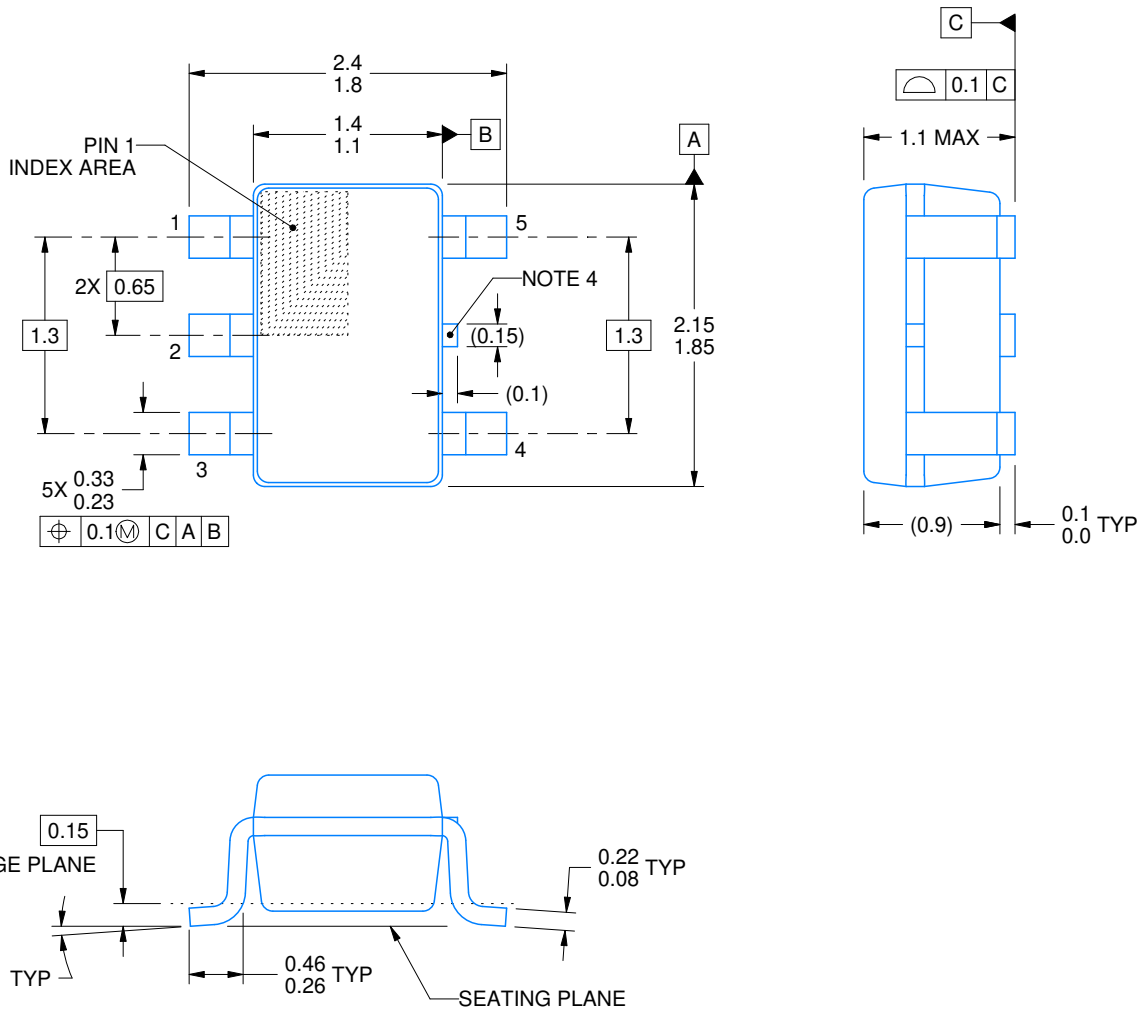
DCK0005A



# PACKAGE OUTLINE

SOT - 1.1 max height

SMALL OUTLINE TRANSISTOR



4214834/C 03/2023

NOTES:

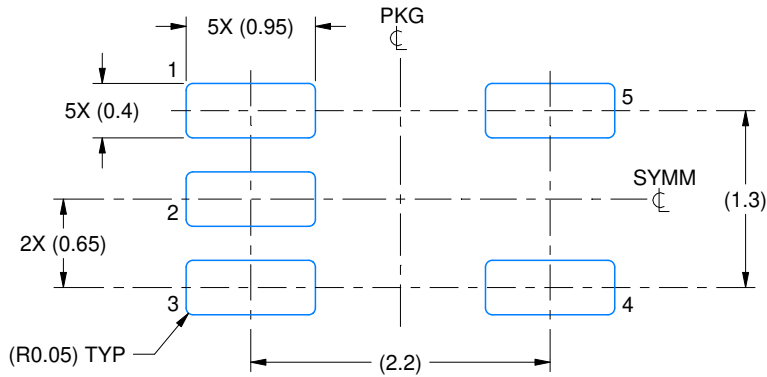
1. All linear dimensions are in millimeters. Any dimensions in parenthesis are for reference only. Dimensioning and tolerancing per ASME Y14.5M.
2. This drawing is subject to change without notice.
3. Reference JEDEC MO-203.
4. Support pin may differ or may not be present.

# EXAMPLE BOARD LAYOUT

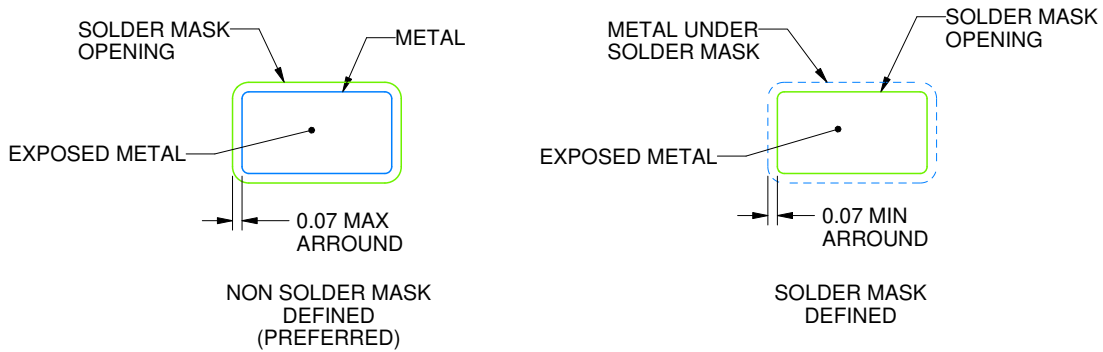
DCK0005A

SOT - 1.1 max height

SMALL OUTLINE TRANSISTOR



LAND PATTERN EXAMPLE  
EXPOSED METAL SHOWN  
SCALE:18X



SOLDER MASK DETAILS

4214834/C 03/2023

NOTES: (continued)

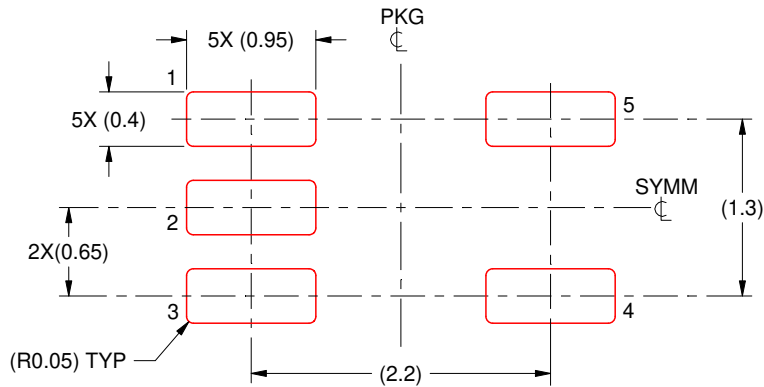
- 4. Publication IPC-7351 may have alternate designs.
- 5. Solder mask tolerances between and around signal pads can vary based on board fabrication site.

# EXAMPLE STENCIL DESIGN

DCK0005A

SOT - 1.1 max height

SMALL OUTLINE TRANSISTOR



SOLDER PASTE EXAMPLE  
BASED ON 0.125 THICK STENCIL  
SCALE:18X

4214834/C 03/2023

NOTES: (continued)

6. Laser cutting apertures with trapezoidal walls and rounded corners may offer better paste release. IPC-7525 may have alternate design recommendations.
7. Board assembly site may have different recommendations for stencil design.

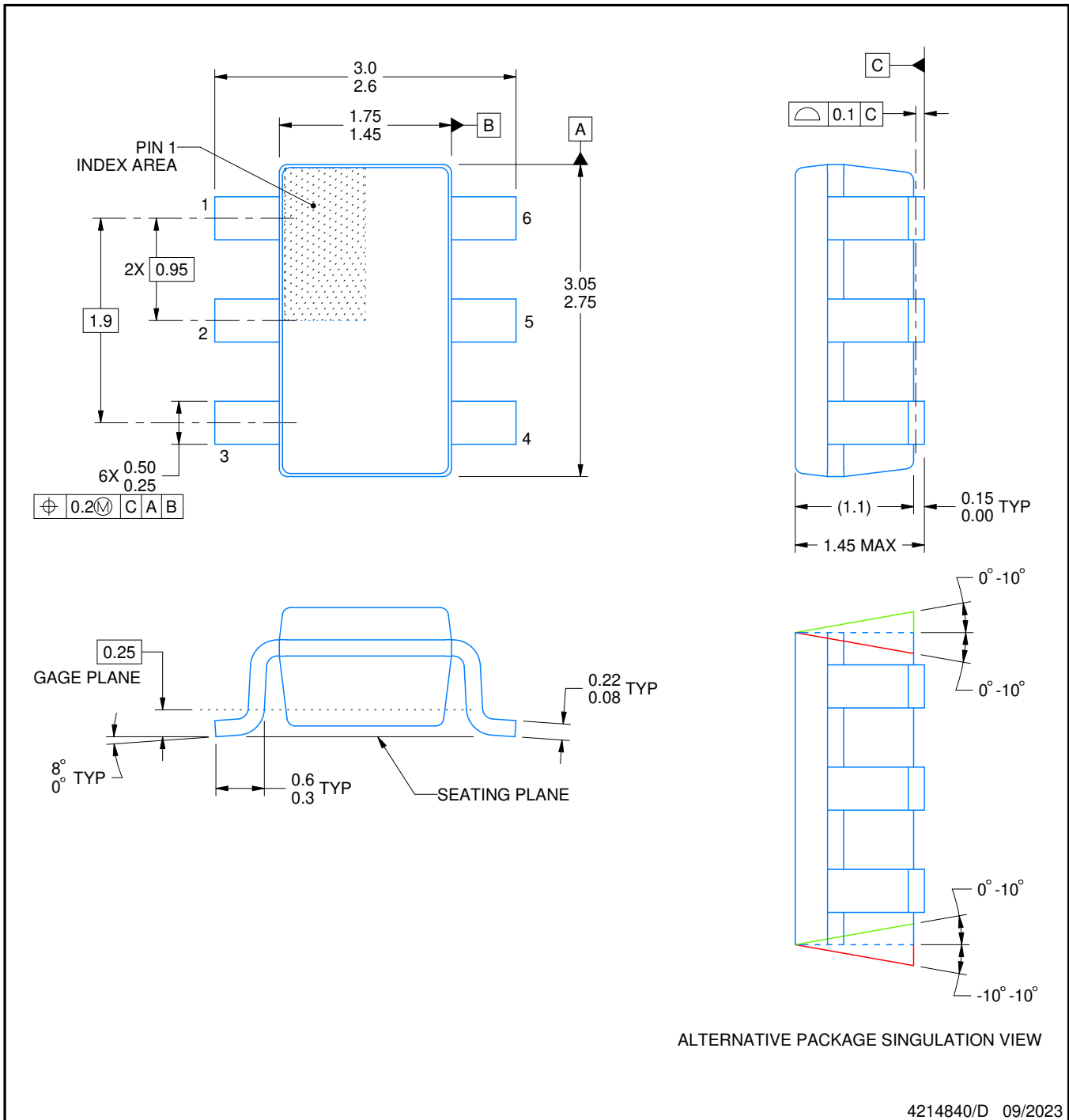
# DBV0006A



## PACKAGE OUTLINE

SOT-23 - 1.45 mm max height

SMALL OUTLINE TRANSISTOR



4214840/D 09/2023

### NOTES:

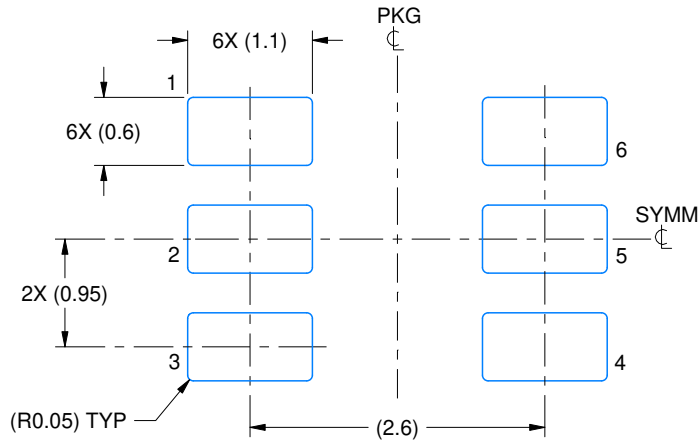
- All linear dimensions are in millimeters. Any dimensions in parenthesis are for reference only. Dimensioning and tolerancing per ASME Y14.5M.
- This drawing is subject to change without notice.
- Body dimensions do not include mold flash or protrusion. Mold flash and protrusion shall not exceed 0.25 per side.
- Leads 1,2,3 may be wider than leads 4,5,6 for package orientation.
- Reference JEDEC MO-178.

# EXAMPLE BOARD LAYOUT

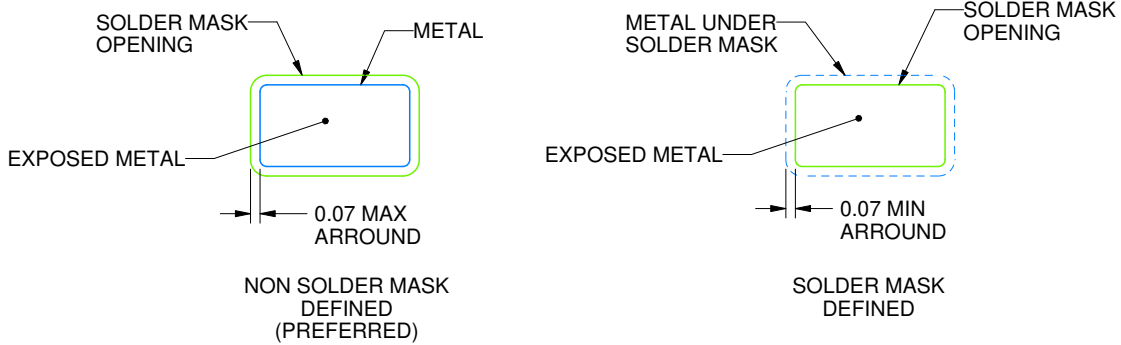
DBV0006A

SOT-23 - 1.45 mm max height

SMALL OUTLINE TRANSISTOR



LAND PATTERN EXAMPLE  
EXPOSED METAL SHOWN  
SCALE:15X



SOLDER MASK DETAILS

4214840/D 09/2023

NOTES: (continued)

6. Publication IPC-7351 may have alternate designs.

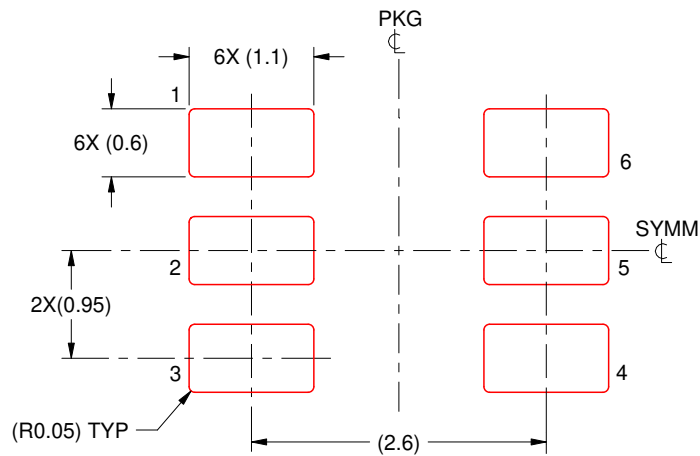
7. Solder mask tolerances between and around signal pads can vary based on board fabrication site.

# EXAMPLE STENCIL DESIGN

DBV0006A

SOT-23 - 1.45 mm max height

SMALL OUTLINE TRANSISTOR



SOLDER PASTE EXAMPLE  
BASED ON 0.125 mm THICK STENCIL  
SCALE:15X

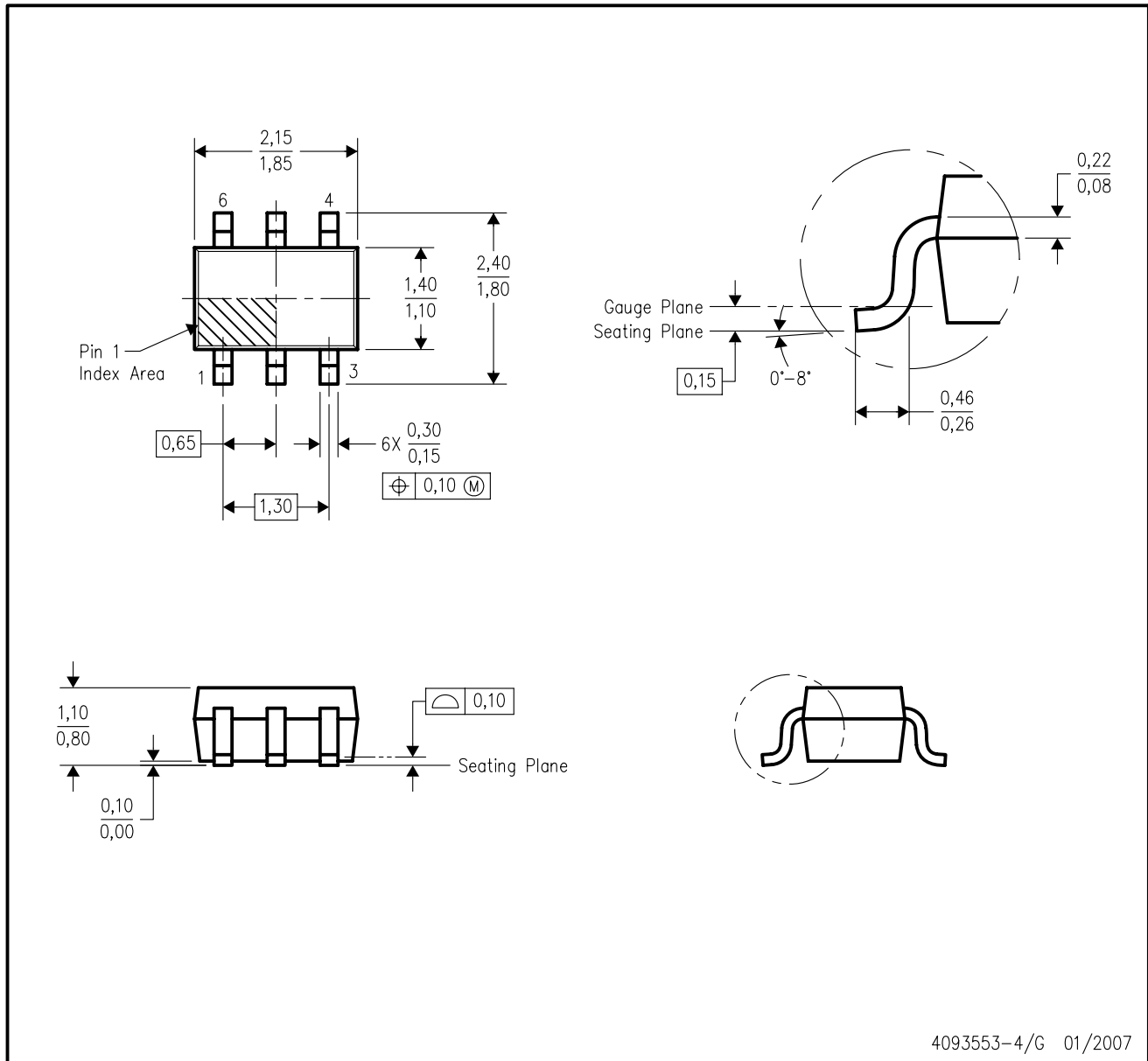
4214840/D 09/2023

NOTES: (continued)

8. Laser cutting apertures with trapezoidal walls and rounded corners may offer better paste release. IPC-7525 may have alternate design recommendations.
9. Board assembly site may have different recommendations for stencil design.

DCK (R-PDSO-G6)

PLASTIC SMALL-OUTLINE PACKAGE

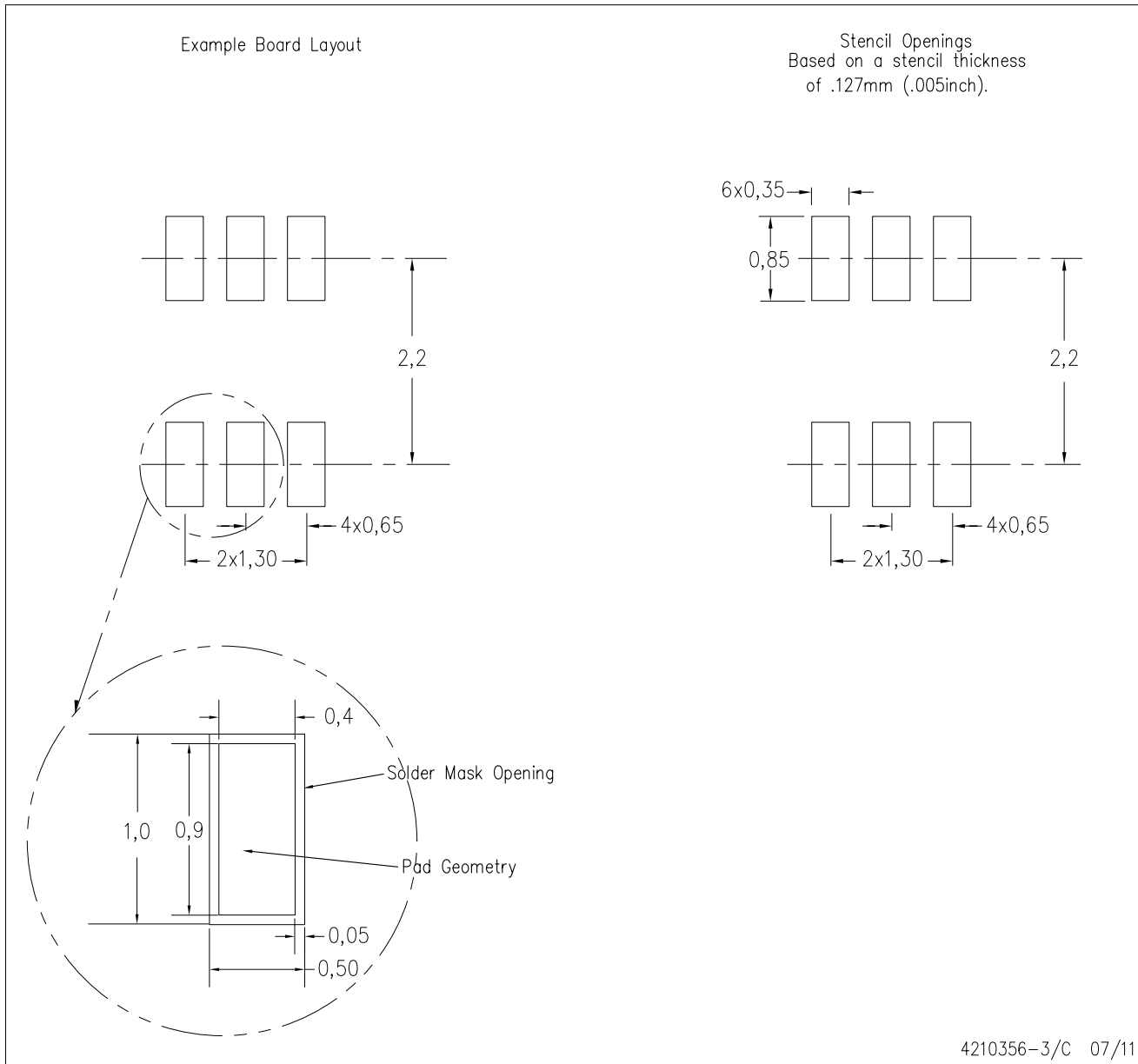


- NOTES:
- A. All linear dimensions are in millimeters.
  - B. This drawing is subject to change without notice.
  - C. Body dimensions do not include mold flash or protrusion. Mold flash and protrusion shall not exceed 0.15 per side.
  - D. Falls within JEDEC MO-203 variation AB.



DCK (R-PDSO-G6)

PLASTIC SMALL OUTLINE



- NOTES:
- All linear dimensions are in millimeters.
  - This drawing is subject to change without notice.
  - Customers should place a note on the circuit board fabrication drawing not to alter the center solder mask defined pad.
  - Publication IPC-7351 is recommended for alternate designs.
  - Laser cutting apertures with trapezoidal walls and also rounding corners will offer better paste release. Customers should contact their board assembly site for stencil design recommendations. Example stencil design based on a 50% volumetric metal load solder paste. Refer to IPC-7525 for other stencil recommendations.

## IMPORTANT NOTICE AND DISCLAIMER

TI PROVIDES TECHNICAL AND RELIABILITY DATA (INCLUDING DATA SHEETS), DESIGN RESOURCES (INCLUDING REFERENCE DESIGNS), APPLICATION OR OTHER DESIGN ADVICE, WEB TOOLS, SAFETY INFORMATION, AND OTHER RESOURCES "AS IS" AND WITH ALL FAULTS, AND DISCLAIMS ALL WARRANTIES, EXPRESS AND IMPLIED, INCLUDING WITHOUT LIMITATION ANY IMPLIED WARRANTIES OF MERCHANTABILITY, FITNESS FOR A PARTICULAR PURPOSE OR NON-INFRINGEMENT OF THIRD PARTY INTELLECTUAL PROPERTY RIGHTS.

These resources are intended for skilled developers designing with TI products. You are solely responsible for (1) selecting the appropriate TI products for your application, (2) designing, validating and testing your application, and (3) ensuring your application meets applicable standards, and any other safety, security, regulatory or other requirements.

These resources are subject to change without notice. TI grants you permission to use these resources only for development of an application that uses the TI products described in the resource. Other reproduction and display of these resources is prohibited. No license is granted to any other TI intellectual property right or to any third party intellectual property right. TI disclaims responsibility for, and you will fully indemnify TI and its representatives against, any claims, damages, costs, losses, and liabilities arising out of your use of these resources.

TI's products are provided subject to [TI's Terms of Sale](#) or other applicable terms available either on [ti.com](https://www.ti.com) or provided in conjunction with such TI products. TI's provision of these resources does not expand or otherwise alter TI's applicable warranties or warranty disclaimers for TI products.

TI objects to and rejects any additional or different terms you may have proposed.

Mailing Address: Texas Instruments, Post Office Box 655303, Dallas, Texas 75265  
Copyright © 2023, Texas Instruments Incorporated