

Reference Design Based on ATR2406 and ATmega88

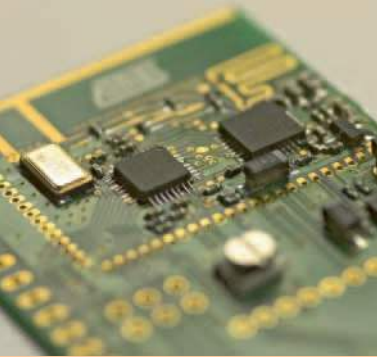

Atmel's reference design addresses the need for cost-effective and flexible cable-replacement solutions, and offers a complete solution allowing fast time-to-market cycles. It features Atmel's ATR2406 2.4-GHz Smart RF transceiver and the ATmega88 AVR[®] microcontroller. The proprietary Smart RF firmware implements an adaptive frequency-hopping protocol, enabling robust and reliable data transmission even in a noisy RF environment with interfering signals from WLAN, Bluetooth[®], WDCT systems and microwave ovens. The reference design is especially designed to meet the performance and cost requirements of wireless game controllers, but also addresses other wire-replacement applications in the consumer area, such as wireless audio links, interactive intelligent toys and remote controls.



Reference Design Benefits

Maximum Flexibility

- Operates in the Worldwide-available License-free 2.4-GHz ISM Band
- Two-chip Solution Allows the User to Select the Appropriate ATmega48/88/168 AVR According to the Application Firmware Needs



High Performance

- Link Ranges of up to 150 m in Free Space and 30 m Indoor Without External Power Amplifier or LNA
- Maximum Data Throughput and Short Transmission Burst for Low-power Applications, Thanks to the High Over-the-air Data Transmission Rate of 1.152 Mbit/s



ISM Reference Design

Low Manufacturing Costs

- Standard 2-layer Circuit Board with Minimal Number of External Components
- Low Bill of Material (BOM) Costs Since Printed F Antenna, Balun and Filter are Included
- Single Crystal for AVR and Smart RF Transceiver



Fast Time-to-market

- Complete Smart RF Firmware with Adaptive Frequency-hopping Scheme in C Code, Easily Adaptable to the Applications' Needs
- The ATmega48/88/168 AVR Is Supported with a Full Suite of Program and System Development Tools Including C Compilers, Macro Assemblers, Program Debugger/Simulators, and In-Circuit Emulators
- Complete Manufacturing Data Available

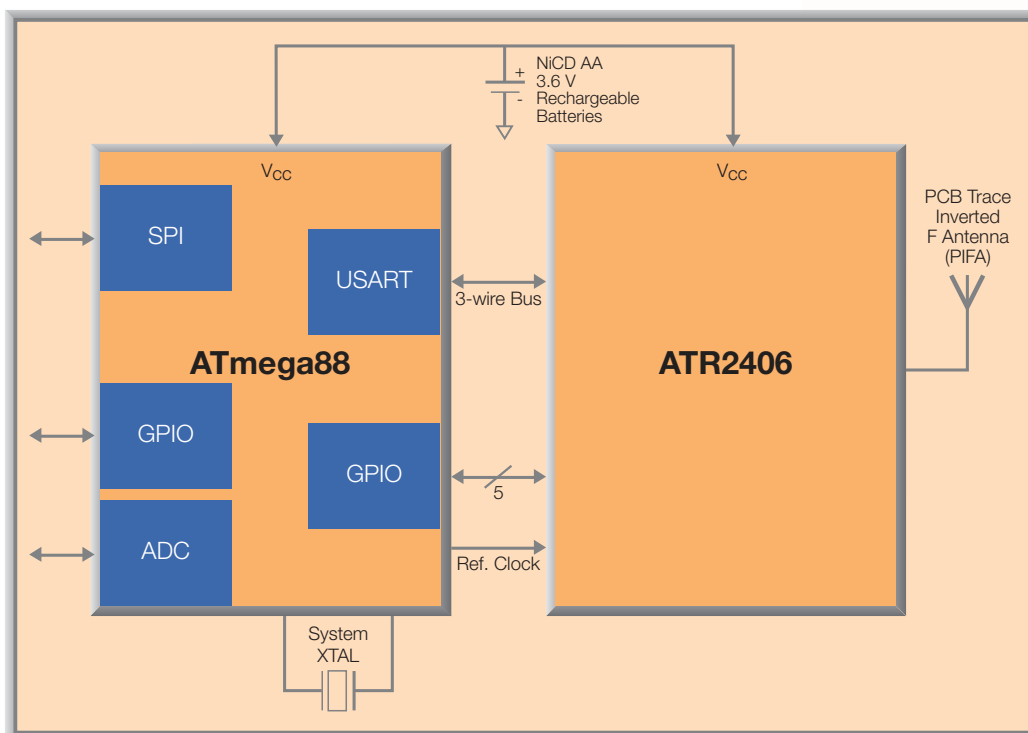

Atmel Corporation

2325 Orchard Parkway
San Jose, CA 95131, USA
Tel.: (1) 408 441-0311
Fax: (1) 408 487-2600

Regional Headquarters

Europe

Atmel Sarl
Route des Arsenaux 41
Case Postale 80
CH-1705 Fribourg
Switzerland
Tel.: (41) 26-426-5555
Fax: (41) 26-426-5500

Asia

Room 1219
Chinachem Golden Plaza
77 Mody Road Tsimshatsui
East Kowloon
Hong Kong
Tel.: (852) 2721-9778
Fax: (852) 2722-1369

Japan

9F, Tonetsu Shinkawa Bldg.
1-24-8 Shinkawa
Chuo-ku, Tokyo 104-0033
Japan
Tel.: (81) 3-3523-3551
Fax: (81) 3-3523-7581

Product Contact

Theresienstrasse 2
P.O.B. 3535
D-74025 Heilbronn
Germany
Tel.: (49) 71 31-67-0
Fax: (49) 71 31-67-2340

Literature Requests

www.atmel.com/literature

Web Site

www.atmel.com



© Atmel Corporation 2005.
All rights reserved.

Atmel®, logo and combinations thereof, Everywhere You Are®, AVR®, and others, are registered trademarks or trademarks of Atmel Corporation or its subsidiaries. Other terms and product names may be trademarks of others.

Rev.: 4624B-ISM-05/05/05M

Technical Parameters

Link Range	Up to 30 m indoor, up to 150 m outdoor
Average Data Rate	0 – 704 Kbit/s
Over-the-air Data Rate	1.152 Mbit/s
Channels	89 channels
Free Application Ports	SPI interface 15 configurable user pins: 13 free I/O + 2 free ADC or 8 free I/O + 7 free ADC
Board Size	17 mm x 28 mm, 2 layer FR4
Applicable Standards	ETSI EN300 328, EN 300 440 FCC CFR 47 Part15 ARIB STD-T-66

Availability and Ordering Information

The Reference Design is part of the ATR2406 Evaluation Kit, which also includes a large LCD display and other firmware with demonstration and testing capabilities.



Product Overview

Part Number	Description	Package
ATR2406-DEV-KIT2	ATR2406 Evaluation Kit	
ATR2406-PNSG	2.4-GHz Smart RF Transceiver	QFN 32
ATmega48-20MI	AVR 8-bit Microcontroller, 4k Flash	QFN 32
ATmega88-20MI	AVR 8-bit Microcontroller, 8k Flash	QFN 32
ATmega168-20MI	AVR 8-bit Microcontroller, 16k Flash	QFN 32

For detailed information, please visit <http://www.atmel.com/products/smartrf/> or <http://www.atmel.com/products/avr/>, or contact your local Atmel Sales offices.