

THIS DRAWING IS UNPUBLISHED. RELEASED FOR PUBLICATION, 19 .  
 © COPYRIGHT 19 BY AMP INCORPORATED. ALL RIGHTS RESERVED.

LOC	DIST	REVISIONS			
P	LTR	DESCRIPTION	DATE	DWN	APVD
AF	50	K	REV PER OG3A-0679-03	27OCT03	JR DD

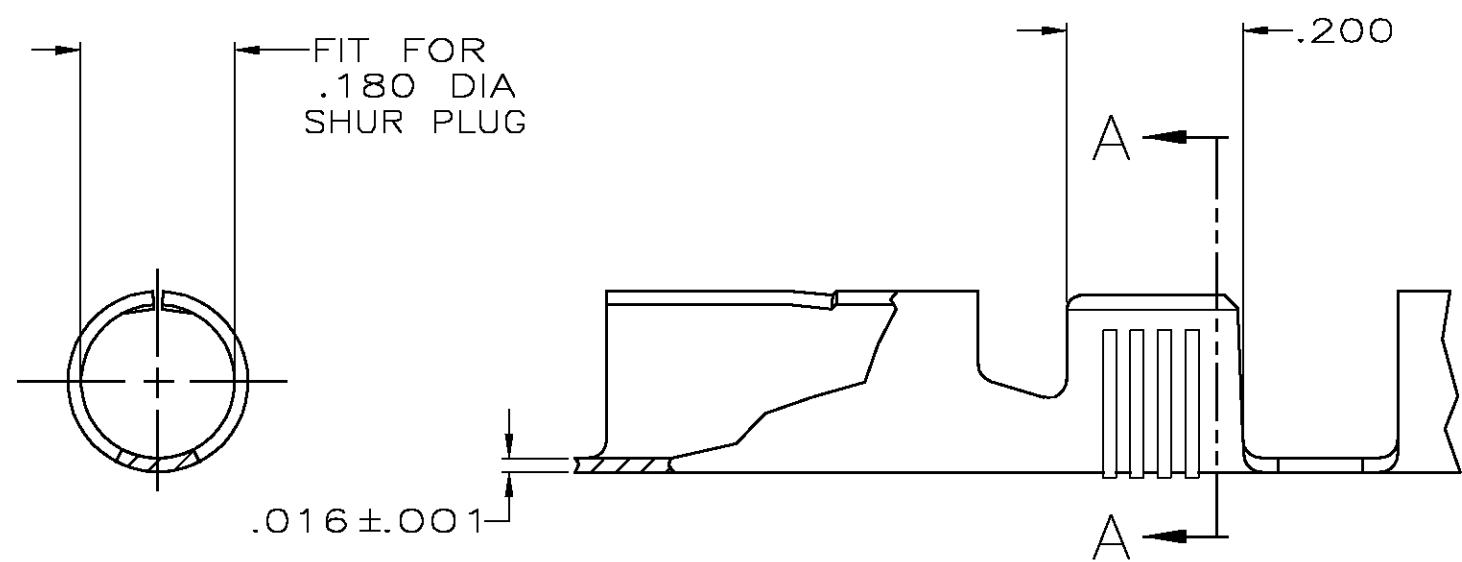

- 1 CONTINUOUS STRIP ON REELS.
- △2 .000080 MIN TIN PLATE.
- △3 .000080 MIN TIN PLATE OVER .000050 MIN NICKEL UNDERPLATE.
- △4 .000150 MIN NICKEL PLATE
- △5 PRELIMINARY - NOT FOR PRODUCTION

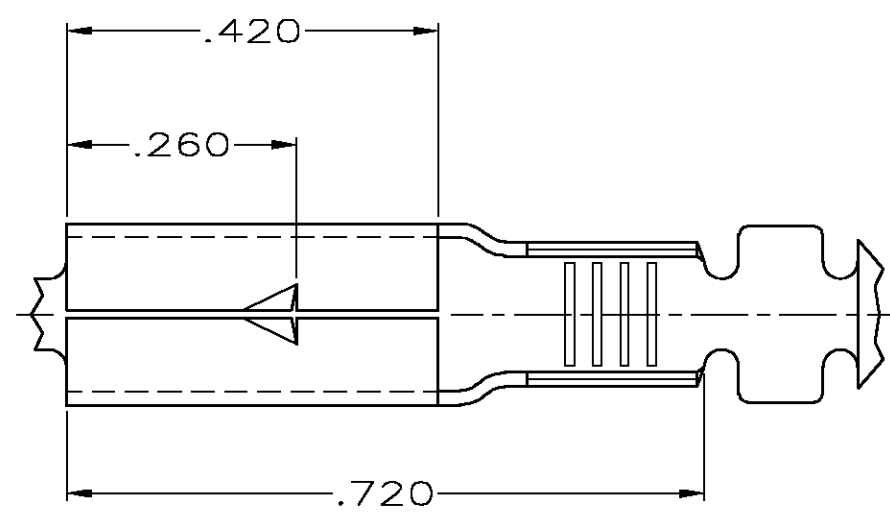
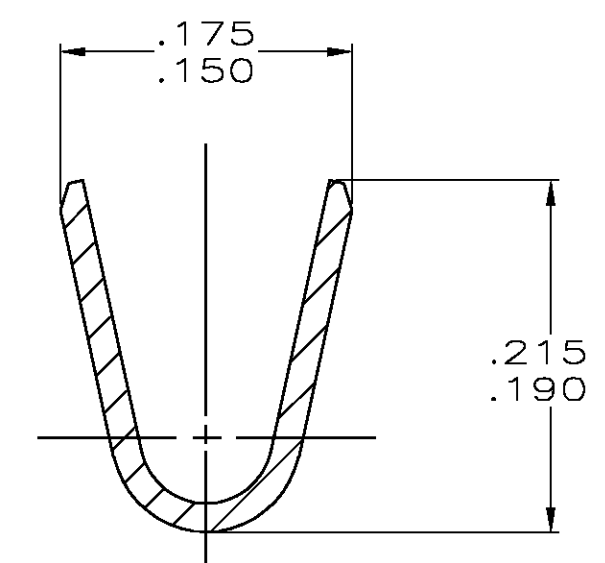

SECTION A-A  
SCALE 10:1

△4	14-10 AWG	△5	42868-4
△3	14-10 AWG		42868-3
△2	14-10 AWG		42868-2
-	14-10 AWG		42868-1
FINISH		WIRE RANGE	
		PART NUMBER	

THIS DRAWING IS A CONTROLLED DOCUMENT.		DWN 12JUL2001 MICHAEL S. FEHER		AMP Incorporated Harrisburg, PA 17105-3608	
DIMENSIONS: INCHES		CHK 12JUL2001 DONALD DECKER			
TOLERANCES UNLESS OTHERWISE SPECIFIED:		APVD 12JUL2001 DONALD DECKER		NAME RECEPTACLE, SHUR PLUG, .180 DIA	
0 PLC ±- 1 PLC ±- 2 PLC ±- 3 PLC ±.010 4 PLC ±- ANGLES ±-		PRODUCT SPEC -		APPLICATION SPEC 114-2017	
MATERIAL 4M BRASS		FINISH SEE TABLE		WEIGHT -	
		SIZE A3		CAGE CODE 00779	
		DRAWING NO C= 42868		RESTRICTED TO -	
		CUSTOMER DRAWING		SCALE 5:1 SHEET 1 OF 1 REV K	