

LEGEND = KEY PRODUCT CHARACTERISTICS



REVISION HISTORY

REV	DESCRIPTION	DATE	BY	CHG/No
0	FIRST ISSUE	05-03-10	MH	---
1	UPDATED DRAWING WITH ADDED DIMENSIONS	01-12-15	MH	----
2	REDUCED METAL WASHER O.D. FROM 15mm TO 14mm	20-04-16	MH	9342

A
B
C
D
E
F

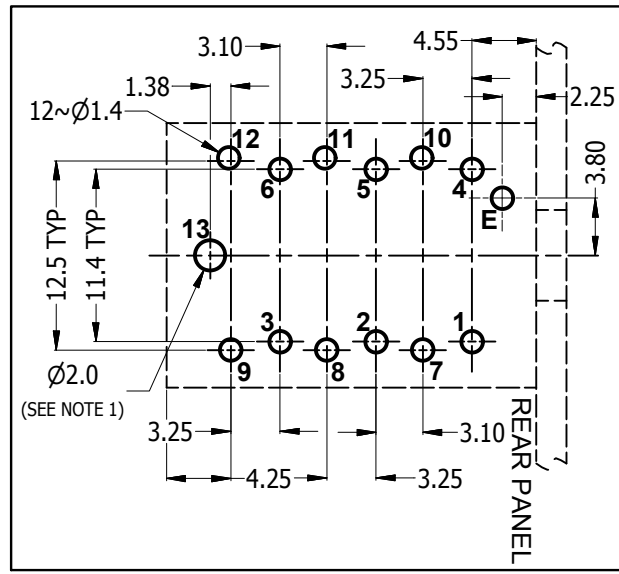
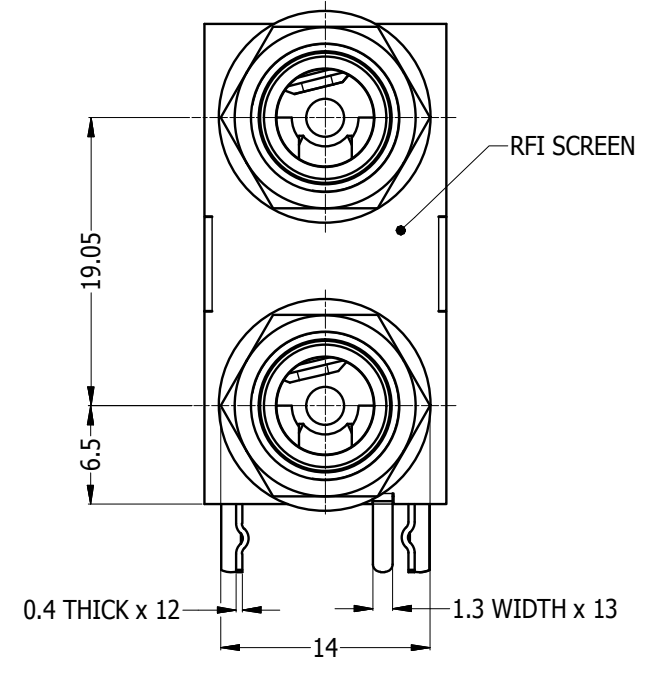
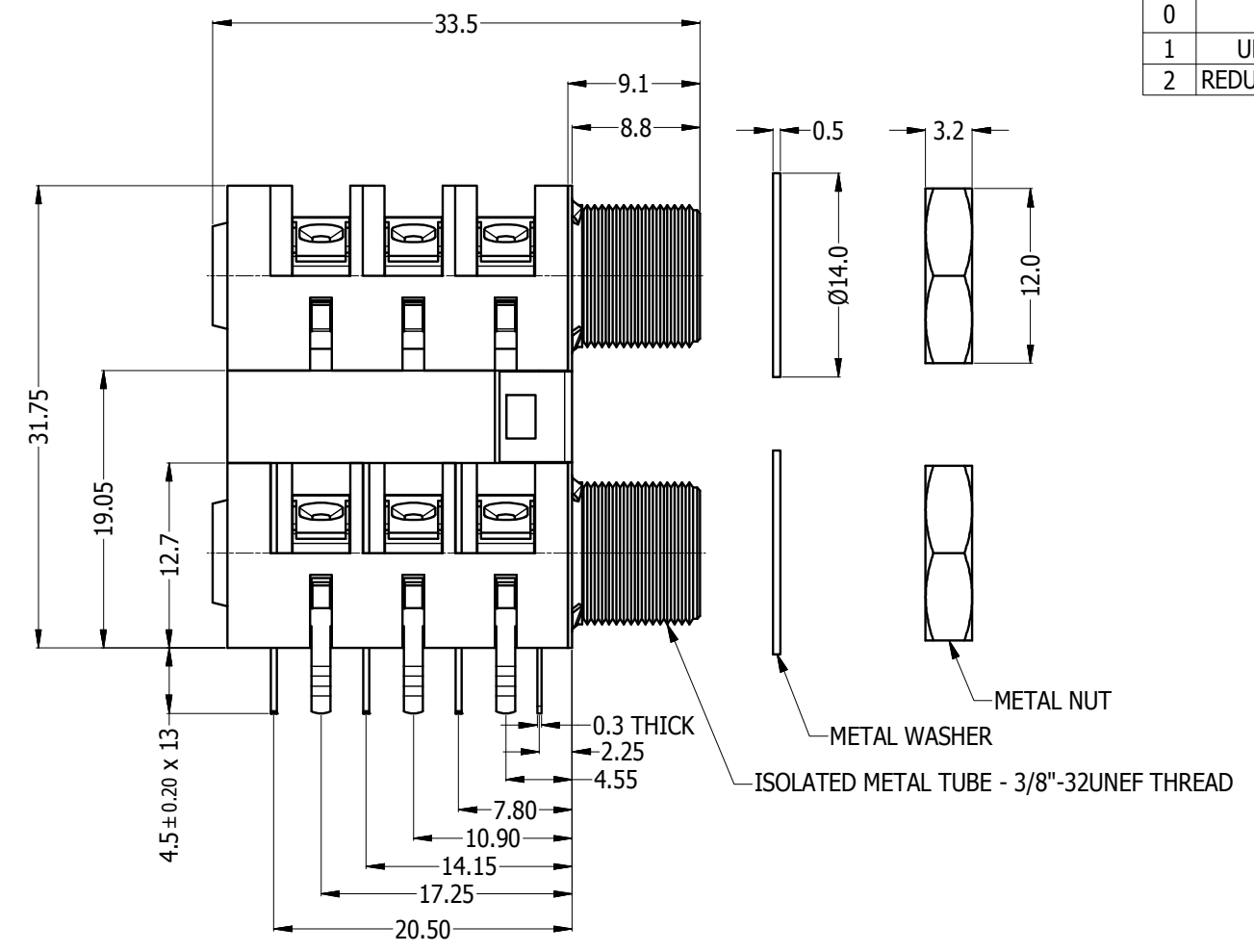
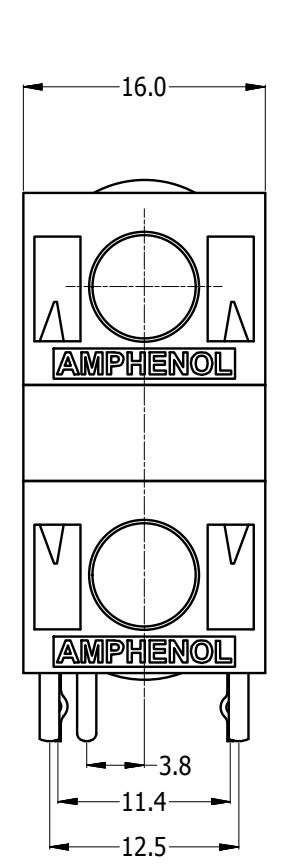

PCB LAYOUT
(CONNECTOR SIDE)

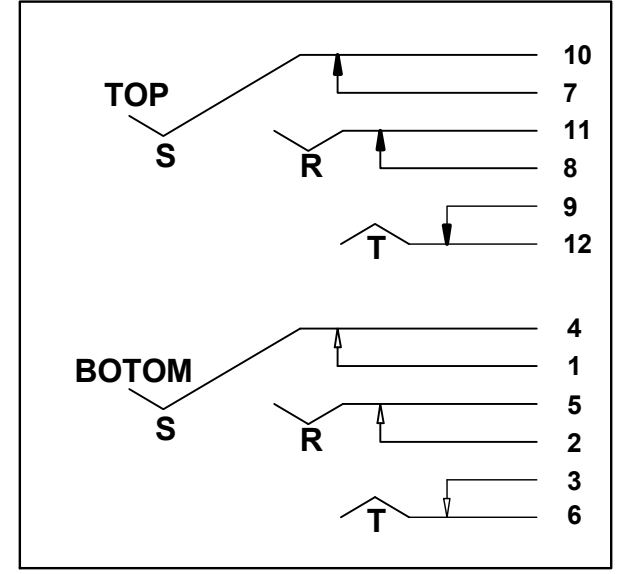

SCHEMATIC DIAGRAM

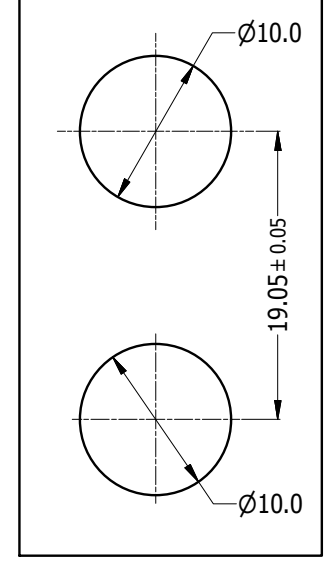

PANEL CUTOUT

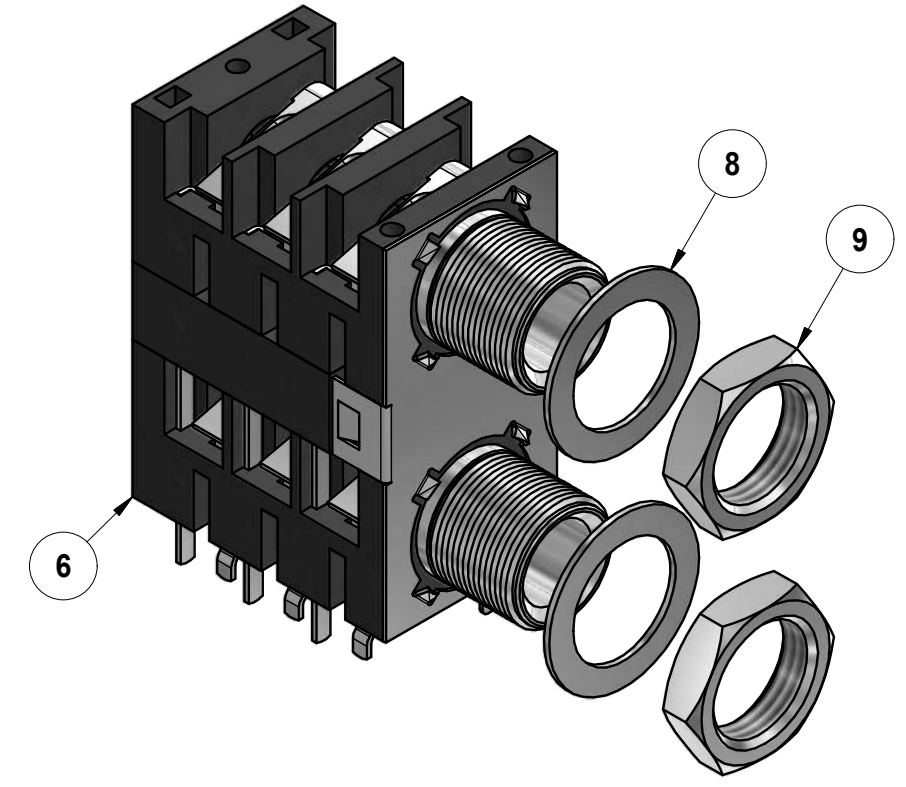

NOTE:
1. OPTIONAL MOUNTING HOLE FOR SELF-TAPPING M2 SCREW.
2. RECOMMENDED MAX TORQUE 2.5N ON METAL NUT ASSEMBLY.

ITEM	PART NUMBER	DESCRIPTION	QTY
6	50300026-331	STAMPED SHORT SPRING CONTACT Sn PLATED	1
9	52170056-331	METAL NUT - Ni PLATED	2
8	52770007-100	METAL WASHER - Ni PLATED	2

PART NUMBER TABLE	
CATALOGUE PN	HARDWARE OPTION
ACJS-LHDEM	NO NUTS & WASHERS
ACJS-MHDEM	METAL NUTS & WASHERS INCLUDED

UNLESS OTHERWISE SPECIFIED TOLERANCE TO BE		THIS DOCUMENT IS THE PROPERTY OF AMPHENOL AUSTRALIA PTY. LTD. NO PART THEREOF MAY BE REPRODUCED AND USED WITHOUT THE PRIOR WRITTEN CONSENT OF THE OWNER			
LINEAR	ANGULAR	MATERIAL:	DRN:	DATE:	TITLE:
X ± 0.5	X' ± 1	REFER TO COMPONENTS	MH	05-03-10	1/4" STEREO DUAL JACK CUSTOMER DRAWING
X.X ± 0.2	X.X' ± 30'	REFER TO COMPONENTS	M.H	20-04-16	
X.XX ± 0.1	X.XX' ± 15'	REFER TO COMPONENTS	P.M	20-04-16	
BREAK ALL SHARP EDGES AND REMOVE ALL BURRS		FINISH:	APP'D:	DATE:	SCALE:
DO NOT SCALE		REFER TO COMPONENTS	P.M	20-04-16	3:1
DIMENSIONS IN MILLIMETRES		THIRD ANGLE PROJECTION		SCALE:	SIZE:
				3:1	A3

Amphenol Amphenol Australia Pty.Ltd, 22 Industry Blvd, Carrum Downs, VIC 3201	
PART No:	SEE TABLE
DRAWING NO.	55010600-000-1
SHEET	1/2

1 2 3 4 5 6 7 8