

THIS DRAWING IS UNPUBLISHED. RELEASED FOR PUBLICATION, 19 .  
 © COPYRIGHT 19 BY AMP INCORPORATED. ALL INTERNATIONAL RIGHTS RESERVED.

MOD	LOC	DIST	P	F	ZONE	LTR	DESCRIPTION	DATE	APPD
2	BD	36				N	REDRAWN W/O CHANGE & REV PER EC 0020-307-94	05/25/94	TC

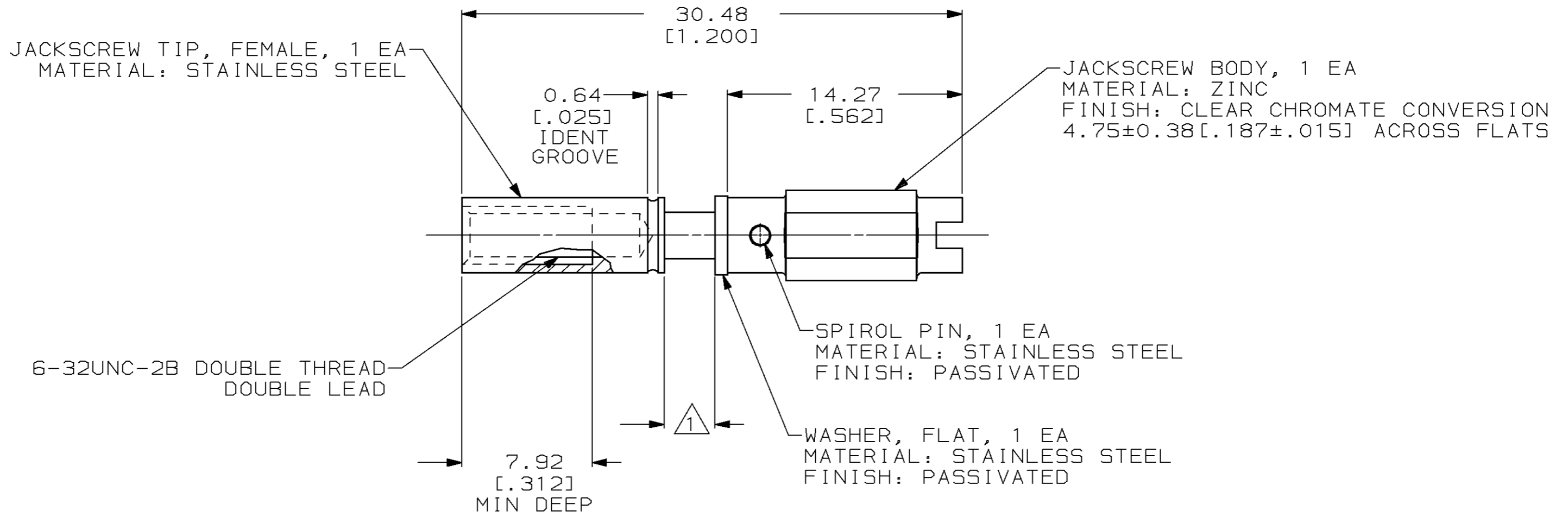

1 METAL THICKNESS OF PIN HOOD OR CABLE CLAMP. WHEN USING BOTH PIN HOOD AND CABLE CLAMP REMOVE WASHER.

THIS DRAWING IS A CONTROLLED DOCUMENT FOR AMP INCORPORATED. IT IS SUBJECT TO CHANGE AND THE CONTROLLING ENGINEERING ORGANIZATION SHOULD BE CONTACTED FOR THE LATEST REVISION.

DO NOT SCALE PRINT. UNLESS SPECIFIED DIMENSIONS IN mm [INCHES] TOLERANCES ON: 2 PLC DEC ± 0.13 [.005] 3 PLC DEC ± - ANGLES ± -		DR 05/25/94 K.FOLTZ	AMP Incorporated Harrisburg, PA 17105-3608
MATERIAL SEE CALLOUT	CHK 06/16/94 R.STONE	APPD 06/17/94 T.COULSON	
FINISH SEE CALLOUT	APPD 06/17/94 T.COULSON	PRODUCT SPEC -	NAME JACKSCREW ASSY, FEMALE, SPECIAL, M SERIES
		APPLICATION SPEC -	SIZE B CAGE CODE 00779 DRAWING NO C-201389
		WEIGHT -	SCALE 4:1 SHEET 1 OF 1

201389-1  
PART NO