

Datasheet



- An easy-to-use, self-contained, opposed-mode sensor pair in a U-shaped housing
- Rugged, sealed, die-cast metal housing is rated IEC IP67 (NEMA 6)
- Easy and economical to mount; molded-in beam guides simplify beam placement
- Eight slot widths from 10 mm to 220 mm for a wide variety of sensing applications
- Current sourcing (PNP), current sinking (NPN), or bipolar (one NPN and one PNP) output, depending on model
- Fast 500-microsecond response time
- 10 V dc to 30 V dc supply voltage
- Single-turn potentiometer sensitivity adjustment
- Visible red beam
- Selectable Light Operate (L.O.) or Dark Operate (D.O.) with sealed switch



WARNING: Not To Be Used for Personnel Protection

Never use this device as a sensing device for personnel **protection**. Doing so could lead to serious injury or death. This device does not include the self-checking redundant circuitry necessary to allow its use in personnel safety applications. A sensor failure or malfunction can cause either an energized or de-energized sensor output condition.

Models

QD Models ¹	Slot Width	Output Type	Cabled Models ²	Slot Width	Output Type
SLM10P6Q	10 mm (0.39 in)	PNP	SLM10B6	10 mm (0.39 in)	Bipolar (one NPN and one PNP)
SLM10N6Q		NPN	SLM20B6	20 mm (0.79 in)	
SLM20P6Q	20 mm (0.79 in)	PNP	SLM30B6	30 mm (1.18 in)	
SLM20N6Q		NPN	SLM50B6	50 mm (1.97 in)	
SLM30P6Q	30 mm (1.18 in)	PNP	SLM80B6	80 mm (3.15 in)	
SLM30N6Q		NPN	SLM120B6	120 mm (4.72 in)	
SLM50P6Q	50 mm (1.97 in)	PNP	SLM180B6	180 mm (7.09 in)	
SLM50N6Q		NPN	SLM220B6	220 mm (8.66 in)	
SLM80P6Q	80 mm (3.15 in)	PNP			
SLM80N6Q		NPN			
SLM120P6Q	120 mm (4.72 in)	PNP			
SLM120N6Q		NPN			
SLM180P6Q	180 mm (7.09 in)	PNP			
SLM180N6Q		NPN			
SLM220P6Q	220 mm (8.66 in)	PNP			
SLM220N6Q		NPN			

¹ Integral 3-pin M8/Pico-style quick disconnect models are listed. Models with a quick disconnect require a mating cordset.

² Integral 2 m (6.5 ft) unterminated cable models are listed.

- To order the 9 m (30 ft) PVC cable model, add the suffix "W/30" to the cabled model number. For example, SLM10B6 W/30.
- To order the 150 mm (6 in) PUR cable model with a 4-pin M12/Euro-style quick disconnect, add the suffix "QPMA" to the model number. For example, SLM10B6QPMA.
- Models with a quick disconnect require a mating cordset.



Overview

The SLM Series Slot Sensor (sometimes called a “fork sensor”) comprises an opposed-mode emitter and its receiver inside a single convenient housing.

Opposed-mode sensing is very reliable, and the single, self-contained housing provides easy installation, with no sensor alignment required. In addition, molded-in arrows on the housing show at a glance the position of the beam, simplifying installation placement. Applications include counting, gear tooth detection, edge detection, part sensing on conveyor rails and belts, position and orientation verification, dimension verification, tool break monitoring, and level monitoring.

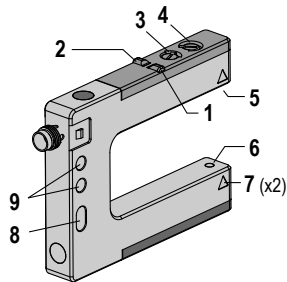

1. Output LED (amber)
2. Power on LED (green)
3. Dark/ Light Operate select switch
4. Sensitivity potentiometer
5. Receiver aperture
6. Emitter aperture
7. Beam position arrows
8. Mounting hole (all models except SLM10 and SLM20)
9. Mounting holes (all models)

Wiring Diagrams

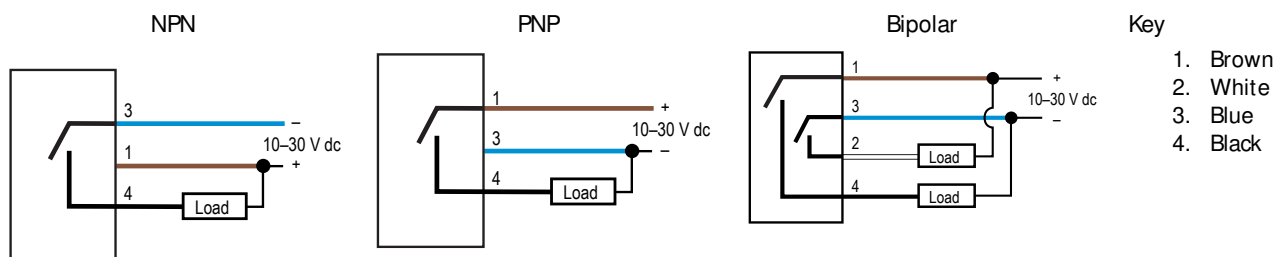

Configuring the Sensor

For the best results, place the objects to be detected midway between the emitter and receiver.

Adjusting the Sensitivity

Adjust the sensor’s sensitivity by turning the 270-degree-turn Sensitivity potentiometer with a small flat-blade screwdriver.

Apply power to the sensor and turn the potentiometer all the way clockwise (maximum gain). If the object to be sensed does not block the beam at the maximum gain, turn the gain down a little at a time, testing with the object, until the object can be sensed reliably.

If adjusting the sensitivity with the potentiometer does not provide reliable object detection, investigate alternative sensing methods.

Selecting Light or Dark Operate

Select dark operate (D.O.) or light operate (L.O.) by turning the DO/LO selector switch to the desired setting using a small flat-blade screwdriver.

If dark operate is selected, the output conducts when the receiver element does not see the emitted light (object is present). If light operate is selected, the output conducts when the receiver element sees the emitted light (object is absent).

Specifications

Supply Voltage and Current

10 V dc to 30 V dc (10% max. ripple) at less than 25 mA, exclusive of load

Supply Protection Circuitry

Protected against reverse polarity and transient voltages

Output Configuration

Cabled and Euro-style QD models: Bipolar: One current sourcing (PNP) and one current sinking (NPN)

Pico-style QD models: Current sourcing (PNP) or current sinking (NPN), depending on model

Output Rating

100 mA with short circuit protection

OFF-state leakage current:

NPN: < 200 µA

PNP: < 10 µA

ON-state saturation voltage:

NPN: 1.6 V at 100 mA

PNP: 2.0 V at 100 mA

Output Protection Circuitry

Protected against output short-circuit and false pulse on power up
100 ms max. delay at power up; outputs do not conduct during this time

Output Response Time

500 microseconds

Repeatability

95 microseconds

Operating Conditions

-20 °C to +60 °C (-4 °F to +140 °F)

95% at +55 °C maximum relative humidity (non-condensing)

Slot Opening

10 mm, 20 mm, 30 mm, 50 mm, 80 mm, 120 mm, 180 mm, or 220 mm (depending on model); beam is 5 mm (0.2 in) from outer edge

Adjustments

1-turn potentiometer sensitivity adjustment
Light/dark operate selection switch

Indicators

Two LED Indicators: Power (green) and Output (amber)

Green on: Power on

Green flashing: Sensor short circuit

Amber on: Output is activated

Construction

Housing: die-cast zinc with nickel plating

Endcaps: ABS

Optic windows: acrylic

Connections

Cabled models: 2 m (6.5 ft) or 9 m (30 ft) 4-conductor, PVC-jacketed cable

Pico-style QD models: 3-pin, threaded integral QD connector

Euro-style QD models: 150 mm (6 in) PUR cable with 4-pin, threaded connector

Environmental Rating

IEC IP67; NEMA 6

Required Overcurrent Protection



WARNING: Electrical connections must be made by qualified personnel in accordance with local and national electrical codes and regulations.

Overcurrent protection is required to be provided by end product application per the supplied table.

Overcurrent protection may be provided with external fusing or via Current Limiting, Class 2 Power Supply.

Supply wiring leads < 24 AWG shall not be spliced.

For additional product support, go to www.bannerengineering.com.

Supply Wiring (AWG)	Required Overcurrent Protection (Amps)
20	5.0
22	3.0
24	2.0
26	1.0
28	0.8
30	0.5

Certifications



	SLM10	SLM20	SLM30	SLM50	SLM80	SLM120	SLM180	SLM220
Minimum object detection at maximum gain ³	1.00 mm (0.040 in)	1.25 mm (0.050 in)	1.50 mm (0.060 in)	1.65 mm (0.065 in)	1.80 mm (0.070 in)	1.80 mm (0.070 in)	1.80 mm (0.070 in)	2.40 mm (0.095 in)
Minimum object detection at 2 times excess gain ³	0.30 mm (0.012 in)	0.30 mm (0.012 in)	0.40 mm (0.016 in)	0.60 mm (0.024 in)	0.75 mm (0.030 in)	0.90 mm (0.035 in)	0.90 mm (0.035 in)	1.00 mm (0.039 in)
Hysteresis ⁴	0.10 mm (0.004 in)	0.10 mm (0.004 in)	0.10 mm (0.004 in)	0.10 mm (0.004 in)	0.20 mm (0.008 in)	0.20 mm (0.008 in)	0.20 mm (0.008 in)	0.20 mm (0.008 in)
Repeatability ⁵	0.02 mm (0.001 in)	0.02 mm (0.001 in)	0.02 mm (0.001 in)	0.04 mm (0.002 in)	0.06 mm (0.002 in)	0.08 mm (0.003 in)	0.08 mm (0.003 in)	0.08 mm (0.003 in)

³ The smallest diameter rod that can be detected when passed slowly through sensing beam. Minimum object detection is measured midway between the emitter and receiver. For best results, place the object to be detected in the midway position when possible. The minimum object detection size may increase if the object is very close to the receiver side.

⁴ The distance an object must move to toggle between output OFF and output ON state.

⁵ The variation in switching distance for a standard target at controlled sensing conditions.

Dimensions

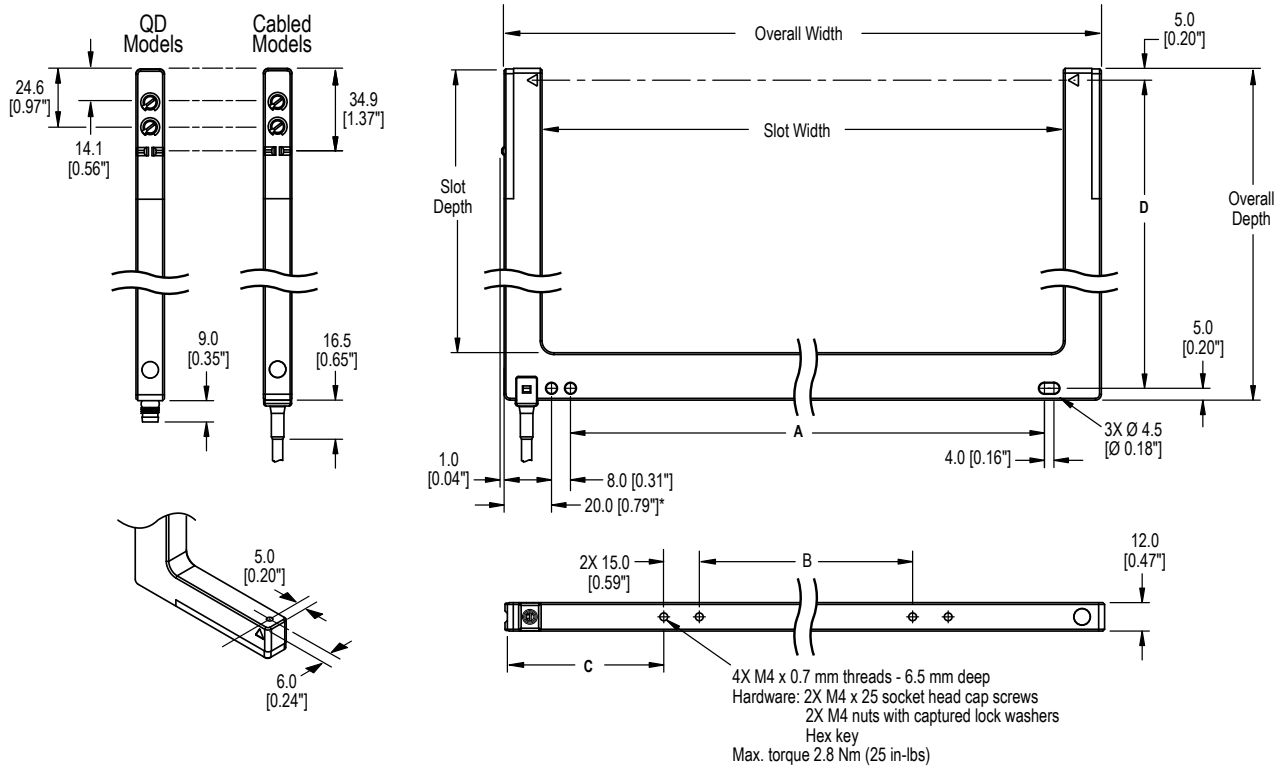

*Model SLM10.. measures 18.0 [0.71"]

All measurements are listed in millimeters [inches], unless noted otherwise.

Models	Slot Width	Slot Depth	Overall Width	Overall Depth	A Side Mount	B Back Mount	C	D
SLM10	10 mm (0.39")	60.8 mm (2.39")	42 mm (1.65")	80 mm (3.15")	n/a	15 mm (0.59")	33.5 mm (1.32")	70 mm (2.76")
SLM20	20 mm (0.79")		52 mm (2.05")		n/a			
SLM30	30 mm (1.18")		62 mm (2.44")		10 mm (0.39")			
SLM50	50 mm (1.97")		82 mm (3.23")		30 mm (1.18")			
SLM80	80 mm (3.15")		112 mm (4.41")		60 mm (2.36")			
SLM120	120 mm (4.72")	120.7 mm (4.75")	152 mm (5.98")	140 mm (5.51")	100 mm (3.94")	30 mm (1.18")	46 mm (1.81")	130 mm (5.12")
SLM180	180 mm (7.09")		212 mm (8.35")		160 mm (6.30")	70 mm (2.76")	56 mm (2.20")	
SLM220	220 mm (8.66")		252 mm (9.92")		200 mm (7.87")	90 mm (3.54")	66 mm (2.60")	

Accessories

3-Pin Threaded M8/ Pico-Style Cordsets				
Model	Length	Style	Dimensions	Pinout (Female)
PKG3M-2	2 m (6.56 ft)	Straight		<p>1 = Brown 3 = Blue 4 = Black</p>
PKG3M-5	5 m (16.40 ft)			
PKG3M-7	7 m (22.97 ft)			
PKG3M-9	9 m (29.53 ft)			
PKW3M-2	2 m (6.56 ft)	Right-Angle		
PKW3M-5	5 m (16.40 ft)			
PKW3M-9	9 m (29.53 ft)			

3-Pin Snap/ Pico-Style Cordsets				
Model	Length	Style	Dimensions	Pinout (Female)
PKG3Z-2	2 m (6.56 ft)	Straight		<p>1 = Brown 3 = Blue 4 = Black</p>
PKW3-2	2 m (6.56 ft)	Right-Angle		

4-Pin Threaded M12/ Euro-Style Cordsets				
Model	Length	Style	Dimensions	Pinout (Female)
MQDC-406	1.83 m (6 ft)	Straight		<p>1 = Brown 2 = White 3 = Blue 4 = Black</p>
MQDC-415	4.57 m (15 ft)			
MQDC-430	9.14 m (30 ft)			
MQDC-450	15.2 m (50 ft)	Right-Angle		
MQDC-406FA	1.83 m (6 ft)			
MQDC-415FA	4.57 m (15 ft)			
MQDC-430FA	9.14 m (30 ft)			
MQDC-450FA	15.2 m (50 ft)			

Banner Engineering Corp. Limited Warranty

Banner Engineering Corp. warrants its products to be free from defects in material and workmanship for one year following the date of shipment. Banner Engineering Corp. will repair or replace, free of charge, any product of its manufacture which, at the time it is returned to the factory, is found to have been defective during the warranty period. This warranty does not cover damage or liability for misuse, abuse, or the improper application or installation of the Banner product.

THIS LIMITED WARRANTY IS EXCLUSIVE AND IN LIEU OF ALL OTHER WARRANTIES WHETHER EXPRESS OR IMPLIED (INCLUDING, WITHOUT LIMITATION, ANY WARRANTY OF MERCHANTABILITY OR FITNESS FOR A PARTICULAR PURPOSE), AND WHETHER ARISING UNDER COURSE OF PERFORMANCE, COURSE OF DEALING OR TRADE USAGE.

This Warranty is exclusive and limited to repair or, at the discretion of Banner Engineering Corp., replacement. IN NO EVENT SHALL BANNER ENGINEERING CORP. BE LIABLE TO BUYER OR ANY OTHER PERSON OR ENTITY FOR ANY EXTRA COSTS, EXPENSES, LOSSES, LOSS OF PROFITS, OR ANY INCIDENTAL, CONSEQUENTIAL OR SPECIAL DAMAGES RESULTING FROM ANY PRODUCT DEFECT OR FROM THE USE OR INABILITY TO USE THE PRODUCT, WHETHER ARISING IN CONTRACT OR WARRANTY, STATUTE, TORT, STRICT LIABILITY, NEGLIGENCE, OR OTHERWISE.

Banner Engineering Corp. reserves the right to change, modify or improve the design of the product without assuming any obligations or liabilities relating to any product previously manufactured by Banner Engineering Corp. Any misuse, abuse, or improper application or installation of this product or use of the product for personal protection applications when the product is identified as not intended for such purposes will void the product warranty. Any modifications to this product without prior express approval by Banner Engineering Corp will void the product warranties. All specifications published in this document are subject to change; Banner reserves the right to modify product specifications or update documentation at any time. Specifications and product information in English supersede that which is provided in any other language. For the most recent version of any documentation, refer to: www.bannerengineering.com.