



2.5V LVDS 1:10 GLITCHLESS CLOCK BUFFER TERABUFFER™ II

IDT5T93GL101

FEATURES:

- Guaranteed Low Skew < 75ps (max)
- Very low duty cycle distortion < 100ps (max)
- High speed propagation delay < 2.2ns (max)
- Up to 450MHz operation
- Selectable inputs
- Hot insertable and over-voltage tolerant inputs
- 3.3V / 2.5V LVTTTL, HSTL, eHSTL, LVEPECL (2.5V), LVPECL (3.3V), CML, or LVDS input interface
- Selectable differential inputs to ten LVDS outputs
- Power-down mode
- 2.5V V_{DD}
- Available in TQFP package

APPLICATIONS:

- Clock distribution

DESCRIPTION:

The IDT5T93GL101 2.5V differential clock buffer is a user-selectable differential input to ten LVDS outputs. The fanout from a differential input to ten LVDS outputs reduces loading on the preceding driver and provides an efficient clock distribution network. The IDT5T93GL101 can act as a translator from a differential HSTL, eHSTL, LVEPECL (2.5V), LVPECL (3.3V), CML, or LVDS input to LVDS outputs. A single-ended 3.3V / 2.5V LVTTTL input can also be used to translate to LVDS outputs. The redundant input capability allows for a glitchless change-over from a primary clock source to a secondary clock source. Selectable inputs are controlled by SEL. During the switchover, the output will disable low for up to three clock cycles of the previously-selected input clock. The outputs will remain low for up to three clock cycles of the newly-selected clock, after which the outputs will start from the newly-selected input. A FSEL pin has been implemented to control the switchover in cases where a clock source is absent or is driven to DC levels below the minimum specifications.

The IDT5T93GL101 outputs can be asynchronously enabled/disabled. When disabled, the outputs will drive to the value selected by the GL pin. Multiple power and grounds reduce noise.

FUNCTIONAL BLOCK DIAGRAM

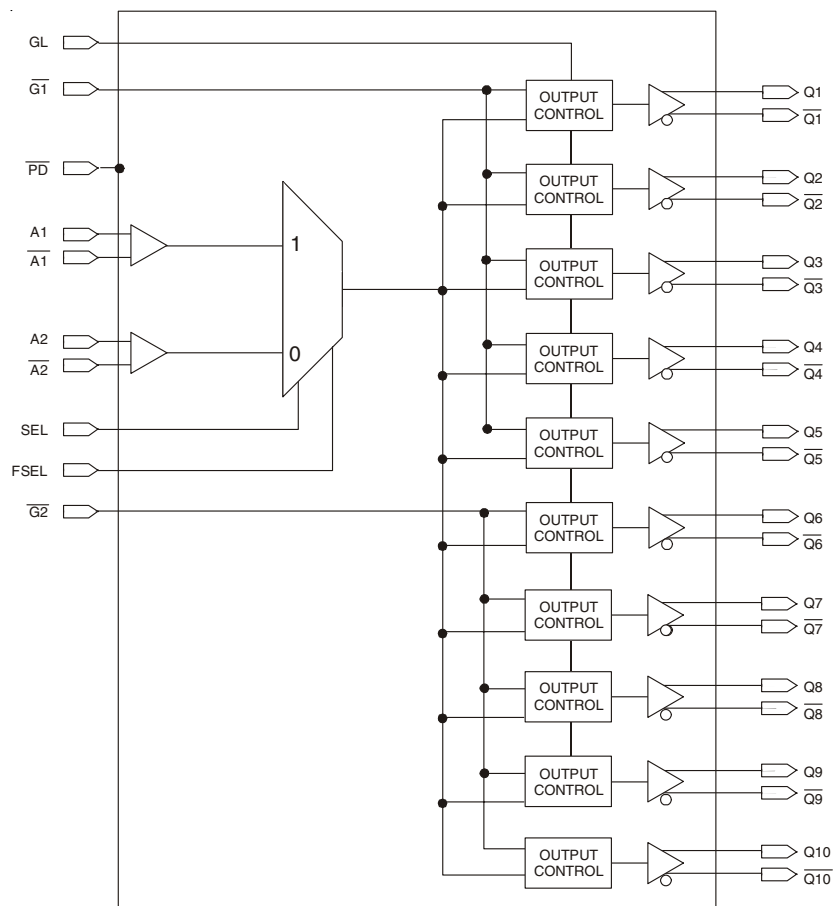

The IDT logo is a registered trademark of Integrated Device Technology, Inc.

INDUSTRIAL TEMPERATURE RANGE

JANUARY 2007

PIN CONFIGURATION

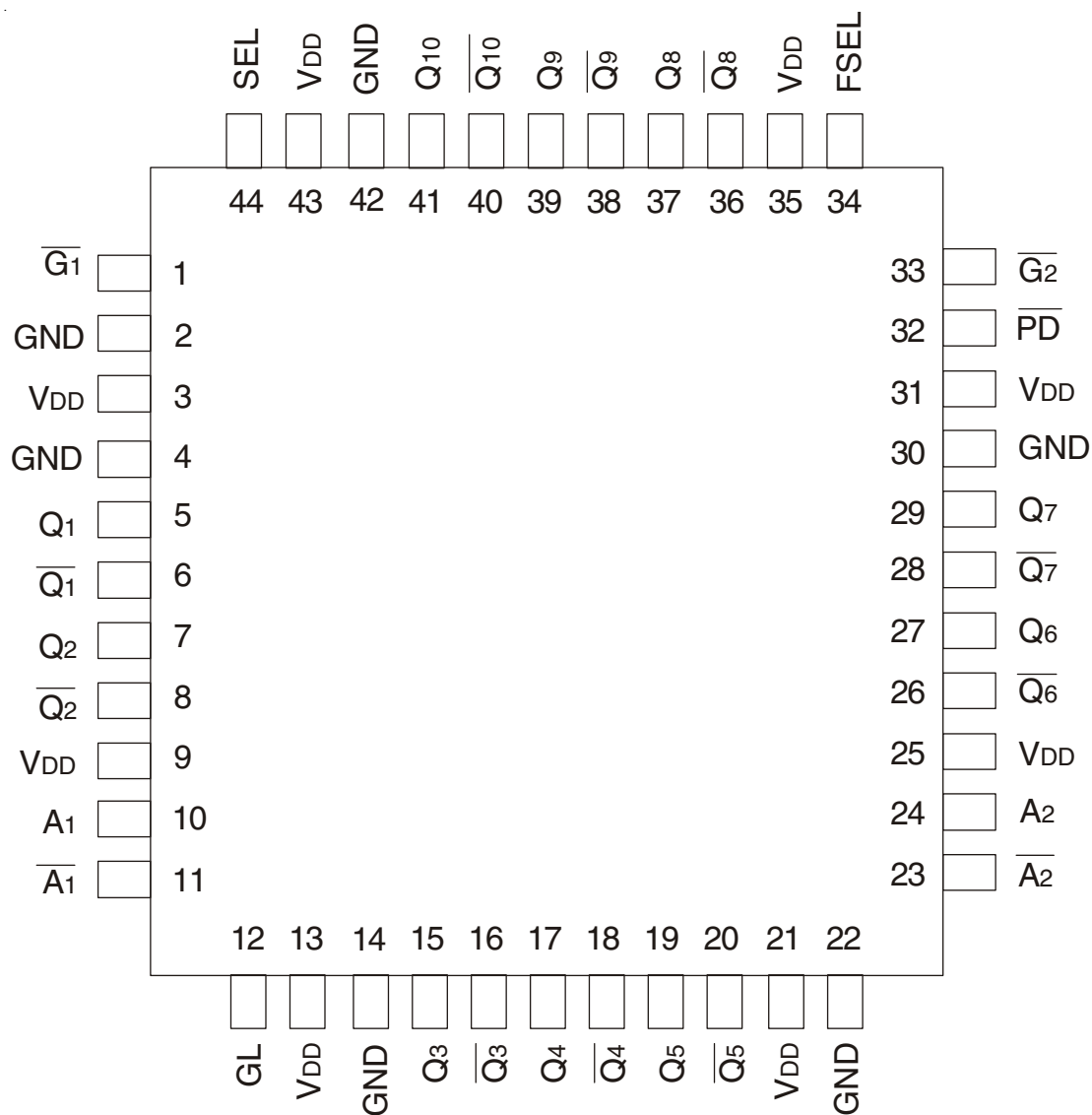

TQFP
 TOP VIEW

ABSOLUTE MAXIMUM RATINGS⁽¹⁾

Symbol	Description	Max	Unit
V _{DD}	Power Supply Voltage	-0.5 to +3.6	V
V _I	Input Voltage	-0.5 to +3.6	V
V _O	Output Voltage ⁽²⁾	-0.5 to V _{DD} +0.5	V
T _{STG}	Storage Temperature	-65 to +150	°C
T _J	Junction Temperature	150	°C

NOTES:

- Stresses greater than those listed under ABSOLUTE MAXIMUM RATINGS may cause permanent damage to the device. This is a stress rating only and functional operation of the device at these or any other conditions above those indicated in the operational sections of this specification is not implied. Exposure to absolute maximum rating conditions for extended periods may affect reliability.
- Not to exceed 3.6V.

CAPACITANCE⁽¹⁾ (T_A = +25°C, F = 1.0MHz)

Symbol	Parameter	Min	Typ.	Max.	Unit
C _{IN}	Input Capacitance	—	—	3	pF

NOTE:

- This parameter is measured at characterization but not tested

RECOMMENDED OPERATING RANGE

Symbol	Description	Min.	Typ.	Max.	Unit
T _A	Ambient Operating Temperature	-40	+25	+85	°C
V _{DD}	Internal Power Supply Voltage	2.3	2.5	2.7	V

PIN DESCRIPTION

Symbol	I/O	Type	Description
A _[1:2]	I	Adjustable ^(1,4)	Clock input. A _[1:2] is the "true" side of the differential clock input.
\bar{A} _[1:2]	I	Adjustable ^(1,4)	Complementary clock inputs. \bar{A} _[1:2] is the complementary side of A _[1:2] . For LVTTTL single-ended operation, \bar{A} _[1:2] should be set to the desired toggle voltage for A _[1:2] : 3.3V LVTTTL V _{REF} = 1650mV 2.5V LVTTTL V _{REF} = 1250mV
\bar{G} ₁	I	LVTTTL	Gate control for differential outputs Q ₁ and \bar{Q} ₁ through Q ₅ and \bar{Q} ₅ . When \bar{G} ₁ is LOW, the differential outputs are active. When \bar{G} ₁ is HIGH, the differential outputs are asynchronously driven to the level designated by GL ⁽²⁾ .
\bar{G} ₂	I	LVTTTL	Gate control for differential outputs Q ₆ and \bar{Q} ₆ through Q ₁₀ and \bar{Q} ₁₀ . When \bar{G} ₂ is LOW, the differential outputs are active. When \bar{G} ₂ is HIGH, the differential outputs are asynchronously driven to the level designated by GL ⁽²⁾ .
GL	I	LVTTTL	Specifies output disable level. If HIGH, "true" outputs disable HIGH and "complementary" outputs disable LOW. If LOW, "true" outputs disable LOW and "complementary" outputs disable HIGH.
Q _n	O	LVDS	Clock outputs
\bar{Q} _n	O	LVDS	Complementary clock outputs
SEL	I	LVTTTL	Reference clock select. When LOW, selects A ₂ and \bar{A} ₂ . When HIGH, selects A ₁ and \bar{A} ₁ .
\bar{P} _D	I	LVTTTL	Power-down control. Shuts off entire chip. If LOW, the device goes into low power mode. Inputs and outputs are disabled. Both "true" and "complementary" outputs will pull to V _{DD} . Set HIGH for normal operation. ⁽³⁾
FSEL	I	LVTTTL	At a rising edge, FSEL forces select to the input designated by SEL. Set LOW for normal operation.
V _{DD}		PWR	Power supply for the device core and inputs
GND		PWR	Ground

NOTES:

- Inputs are capable of translating the following interface standards:
 - Single-ended 3.3V and 2.5V LVTTTL levels
 - Differential HSTL and eHSTL levels
 - Differential LVEPECL (2.5V) and LVPECL (3.3V) levels
 - Differential LVDS levels
 - Differential CML levels
- Because the gate controls are asynchronous, runt pulses are possible. It is the user's responsibility to either time the gate control signals to minimize the possibility of runt pulses or be able to tolerate them in down stream circuitry.
- It is recommended that the outputs be disabled before entering power-down mode. It is also recommended that the outputs remain disabled until the device completes power-up after asserting \bar{P} _D.
- The user must take precautions with any differential input interface standard being used in order to prevent instability when there is no input signal.

DC ELECTRICAL CHARACTERISTICS OVER RECOMMENDED OPERATING RANGE FOR LVTTTL⁽¹⁾

Symbol	Parameter	Test Conditions	Min.	Typ. ⁽²⁾	Max	Unit
Input Characteristics						
I _{IH}	Input HIGH Current	V _{DD} = 2.7V	—	—	±5	μA
I _{IL}	Input LOW Current	V _{DD} = 2.7V	—	—	±5	
V _{IK}	Clamp Diode Voltage	V _{DD} = 2.3V, I _{IN} = -18mA	—	-0.7	-1.2	V
V _{IN}	DC Input Voltage		-0.3		+3.6	V
V _{IH}	DC Input HIGH		1.7		—	V
V _{IL}	DC Input LOW		—		0.7	V
V _{THI}	DC Input Threshold Crossing Voltage		—	V _{DD} /2	—	V
V _{REF}	Single-Ended Reference Voltage ⁽³⁾	3.3V LVTTTL	—	1.65	—	V
		2.5V LVTTTL	—	1.25	—	

NOTES:

1. See RECOMMENDED OPERATING RANGE table.
2. Typical values are at V_{DD} = 2.5V, +25°C ambient.
3. For A_[1:2] single-ended operation, $\bar{A}_{[1:2]}$ is tied to a DC reference voltage.

DC ELECTRICAL CHARACTERISTICS OVER RECOMMENDED OPERATING RANGE FOR DIFFERENTIAL INPUTS⁽¹⁾

Symbol	Parameter	Test Conditions	Min.	Typ. ⁽⁴⁾	Max	Unit
Input Characteristics						
I _{IH}	Input HIGH Current	V _{DD} = 2.7V	—	—	±5	μA
I _{IL}	Input LOW Current	V _{DD} = 2.7V	—	—	±5	
V _{IK}	Clamp Diode Voltage	V _{DD} = 2.3V, I _{IN} = -18mA	—	-0.7	-1.2	V
V _{IN}	DC Input Voltage		-0.3		+3.6	V
V _{DIF}	DC Differential Voltage ⁽²⁾		0.1		—	V
V _{CM}	DC Common Mode Input Voltage ⁽³⁾		0.05		V _{DD}	V

NOTES:

1. See RECOMMENDED OPERATING RANGE table.
2. V_{DIF} specifies the minimum input differential voltage (V_{TR} - V_{CP}) required for switching where V_{TR} is the "true" input level and V_{CP} is the "complement" input level. The DC differential voltage must be maintained to guarantee retaining the existing HIGH or LOW input. The AC differential voltage must be achieved to guarantee switching to a new state.
3. V_{CM} specifies the maximum allowable range of (V_{TR} + V_{CP}) /2.
4. Typical values are at V_{DD} = 2.5V, +25°C ambient.

DC ELECTRICAL CHARACTERISTICS OVER RECOMMENDED OPERATING RANGE FOR LVDS⁽¹⁾

Symbol	Parameter	Test Conditions	Min.	Typ. ⁽²⁾	Max	Unit
Output Characteristics						
V _{OT(+)}	Differential Output Voltage for the True Binary State		247	—	454	mV
V _{OT(-)}	Differential Output Voltage for the False Binary State		247	—	454	mV
ΔV _{OT}	Change in V _{OT} Between Complementary Output States		—	—	50	mV
V _{OS}	Output Common Mode Voltage (Offset Voltage)		1.125	1.2	1.375	V
ΔV _{OS}	Change in V _{OS} Between Complementary Output States		—	—	50	mV
I _{OS}	Outputs Short Circuit Current	V _{OUT +} and V _{OUT -} = 0V	—	12	24	mA
I _{OSD}	Differential Outputs Short Circuit Current	V _{OUT +} = V _{OUT -}	—	6	12	mA

NOTES:

1. See RECOMMENDED OPERATING RANGE table.
2. Typical values are at V_{DD} = 2.5V, +25°C ambient.

DIFFERENTIAL INPUT AC TEST CONDITIONS FOR HSTL

Symbol	Parameter	Value	Units
V _{DIF}	Input Signal Swing ⁽¹⁾	1	V
V _X	Differential Input Signal Crossing Point ⁽²⁾	750	mV
D _H	Duty Cycle	50	%
V _{THI}	Input Timing Measurement Reference Level ⁽³⁾	Crossing Point	V
t _R , t _F	Input Signal Edge Rate ⁽⁴⁾	2	V/ns

NOTES:

1. The 1V peak-to-peak input pulse level is specified to allow consistent, repeatable results in an automatic test equipment (ATE) environment. This device meets the V_{DIF} (AC) specification under actual use conditions.
2. A 750mV crossing point level is specified to allow consistent, repeatable results in an automatic test equipment (ATE) environment. This device meets the V_X specification under actual use conditions.
3. In all cases, input waveform timing is marked at the differential cross-point of the input signals.
4. The input signal edge rate of 2V/ns or greater is to be maintained in the 20% to 80% range of the input waveform.

DIFFERENTIAL INPUT AC TEST CONDITIONS FOR eHSTL

Symbol	Parameter	Value	Units
V _{DIF}	Input Signal Swing ⁽¹⁾	1	V
V _X	Differential Input Signal Crossing Point ⁽²⁾	900	mV
D _H	Duty Cycle	50	%
V _{THI}	Input Timing Measurement Reference Level ⁽³⁾	Crossing Point	V
t _R , t _F	Input Signal Edge Rate ⁽⁴⁾	2	V/ns

NOTES:

1. The 1V peak-to-peak input pulse level is specified to allow consistent, repeatable results in an automatic test equipment (ATE) environment. This device meets the V_{DIF} (AC) specification under actual use conditions.
2. A 900mV crossing point level is specified to allow consistent, repeatable results in an automatic test equipment (ATE) environment. This device meets the V_X specification under actual use conditions.
3. In all cases, input waveform timing is marked at the differential cross-point of the input signals.
4. The input signal edge rate of 2V/ns or greater is to be maintained in the 20% to 80% range of the input waveform.

DIFFERENTIAL INPUT AC TEST CONDITIONS FOR LVEPECL (2.5V) AND LVPECL (3.3V)

Symbol	Parameter	Value	Units
V _{DIF}	Input Signal Swing ⁽¹⁾	732	mV
V _X	Differential Input Signal Crossing Point ⁽²⁾	LVEPECL	1082
		LVPECL	1880
D _H	Duty Cycle	50	%
V _{THI}	Input Timing Measurement Reference Level ⁽³⁾	Crossing Point	V
t _R , t _F	Input Signal Edge Rate ⁽⁴⁾	2	V/ns

NOTES:

1. The 732mV peak-to-peak input pulse level is specified to allow consistent, repeatable results in an automatic test equipment (ATE) environment. This device meets the V_{DIF} (AC) specification under actual use conditions.
2. 1082mV LVEPECL (2.5V) and 1880mV LVPECL (3.3V) crossing point levels are specified to allow consistent, repeatable results in an automatic test equipment (ATE) environment. This device meets the V_X specification under actual use conditions.
3. In all cases, input waveform timing is marked at the differential cross-point of the input signals.
4. The input signal edge rate of 2V/ns or greater is to be maintained in the 20% to 80% range of the input waveform.

DIFFERENTIAL INPUT AC TEST CONDITIONS FOR LVDS

Symbol	Parameter	Value	Units
V _{DIF}	Input Signal Swing ⁽¹⁾	400	mV
V _X	Differential Input Signal Crossing Point ⁽²⁾	1.2	V
D _H	Duty Cycle	50	%
V _{THI}	Input Timing Measurement Reference Level ⁽³⁾	Crossing Point	V
t _R , t _F	Input Signal Edge Rate ⁽⁴⁾	2	V/ns

NOTES:

1. The 400mV peak-to-peak input pulse level is specified to allow consistent, repeatable results in an automatic test equipment (ATE) environment. This device meets the V_{DIF} (AC) specification under actual use conditions.
2. A 1.2V crossing point level is specified to allow consistent, repeatable results in an automatic test equipment (ATE) environment. This device meets the V_X specification under actual use conditions.
3. In all cases, input waveform timing is marked at the differential cross-point of the input signals.
4. The input signal edge rate of 2V/ns or greater is to be maintained in the 20% to 80% range of the input waveform.

AC DIFFERENTIAL INPUT SPECIFICATIONS⁽¹⁾

Symbol	Parameter	Min.	Typ.	Max	Unit
V _{DIF}	AC Differential Voltage ⁽²⁾	0.1	—	3.6	V
V _{IX}	Differential Input Crosspoint Voltage	0.05	—	V _{DD}	V
V _{CM}	Common Mode Input Voltage Range ⁽³⁾	0.05	—	V _{DD}	V
V _{IN}	Input Voltage	-0.3		+3.6	V

NOTES:

1. The output will not change state until the inputs have crossed and the minimum differential voltage defined by V_{DIF} has been met or exceeded.
2. V_{DIF} specifies the minimum input voltage (V_{TR} - V_{CP}) required for switching where V_{TR} is the "true" input level and V_{CP} is the "complement" input level. The AC differential voltage must be achieved to guarantee switching to a new state.
3. V_{CM} specifies the maximum allowable range of (V_{TR} + V_{CP}) /2.

POWER SUPPLY CHARACTERISTICS FOR LVDS OUTPUTS⁽¹⁾

Symbol	Parameter	Test Conditions	Typ.	Max	Unit
I _{DDQ}	Quiescent V _{DD} Power Supply Current	V _{DD} = Max., All Input Clocks = LOW ⁽²⁾ Outputs enabled	—	295	mA
I _{TOT}	Total Power V _{DD} Supply Current	V _{DD} = 2.7V., F _{REFERENCE CLOCK} = 450MHz	—	305	mA
I _{PD}	Total Power Down Supply Current	\overline{PD} = LOW	—	5	mA

NOTES:

1. These power consumption characteristics are for all the valid input interfaces and cover the worst case conditions.
2. The true input is held LOW and the complementary input is held HIGH.

AC ELECTRICAL CHARACTERISTICS OVER OPERATING RANGE^(1,5)

Symbol	Parameter	Min.	Typ.	Max	Unit
--------	-----------	------	------	-----	------

Skew Parameters

$t_{sk(o)}$	Same Device Output Pin-to-Pin Skew ⁽²⁾	—	—	75	ps
$t_{sk(P)}$	Pulse Skew ⁽³⁾	—	—	100	ps
$t_{sk(PP)}$	Part-to-Part Skew ⁽⁴⁾	—	—	300	ps

Propagation Delay

t_{PLH}	Propagation Delay A, \bar{A} Crosspoint to Q_n , \bar{Q}_n Crosspoint	—	1.5	2.2	ns
t_{PHL}					
f_o	Frequency Range ⁽⁶⁾	—	—	450	MHz

Output Gate Enable/Disable Delay

t_{PGE}	Output Gate Enable Crossing V_{THI} to Q_n/\bar{Q}_n Crosspoint	—	—	3.5	ns
t_{PGD}	Output Gate Disable Crossing V_{THI} to Q_n/\bar{Q}_n Crosspoint Driven to GL Designated Level	—	—	3.5	ns

Power Down Timing

t_{PWRDN}	\bar{PD} Crossing V_{THI} to $Q_n = V_{DD}$, $\bar{Q}_n = V_{DD}$	—	—	100	μ S
t_{PWRUP}	Output Gate Disable Crossing V_{THI} to Q_n/\bar{Q}_n Driven to GL Designated Level	—	—	100	μ S

NOTES:

1. AC propagation measurements should not be taken within the first 100 cycles of startup.
2. Skew measured between crosspoints of all differential output pairs under identical input and output interfaces, transitions and load conditions on any one device.
3. Skew measured is the difference between propagation delay times t_{PHL} and t_{PLH} of any single differential output pair under identical input and output interfaces, transitions and load conditions on any one device.
4. Skew measured is the magnitude of the difference in propagation times between any single differential output pair of two devices, given identical transitions and load conditions at identical V_{DD} levels and temperature.
5. All parameters are tested with a 50% input duty cycle.
6. Guaranteed by design but not production tested.

DIFFERENTIAL AC TIMING WAVEFORMS

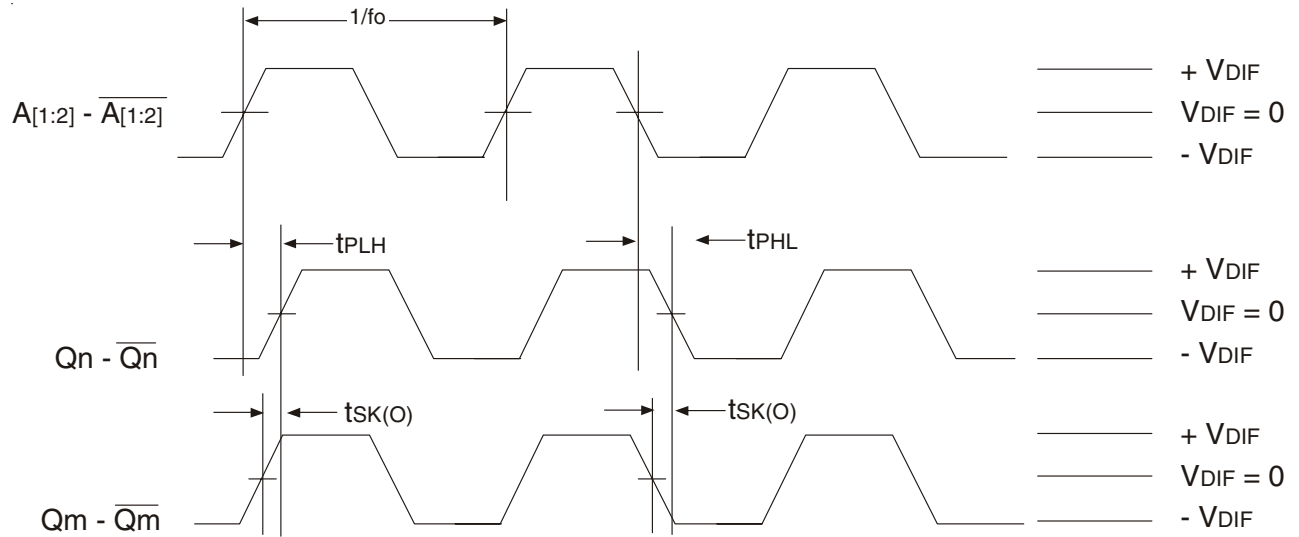

Output Propagation and Skew Waveforms

NOTES:

1. Pulse skew is calculated using the following expression:

$$t_{sk(P)} = |t_{PHL} - t_{PLH}|$$

Note that the t_{PHL} and t_{PLH} shown above are not valid measurements for this calculation because they are not taken from the same pulse.

2. AC propagation measurements should not be taken within the first 100 cycles of startup.

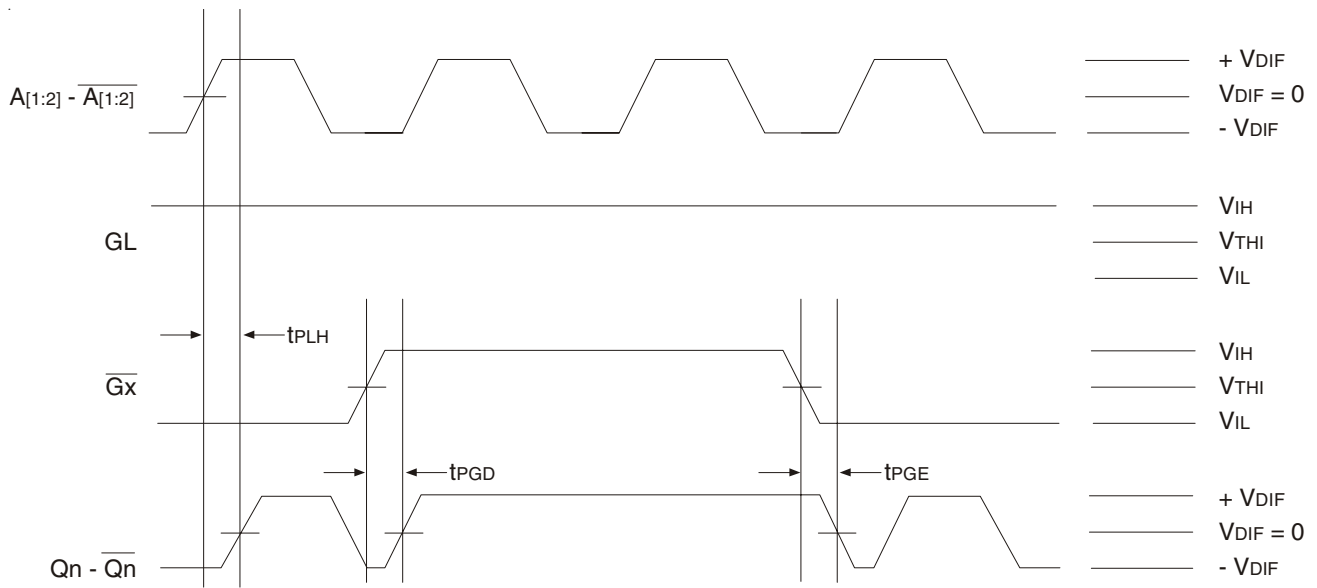

Differential Gate Disable/Enable Showing Runt Pulse Generation

NOTE:
1. As shown, it is possible to generate runt pulses on gate disable and enable of the outputs. It is the user's responsibility to time their \overline{Gx} signals to avoid this problem.

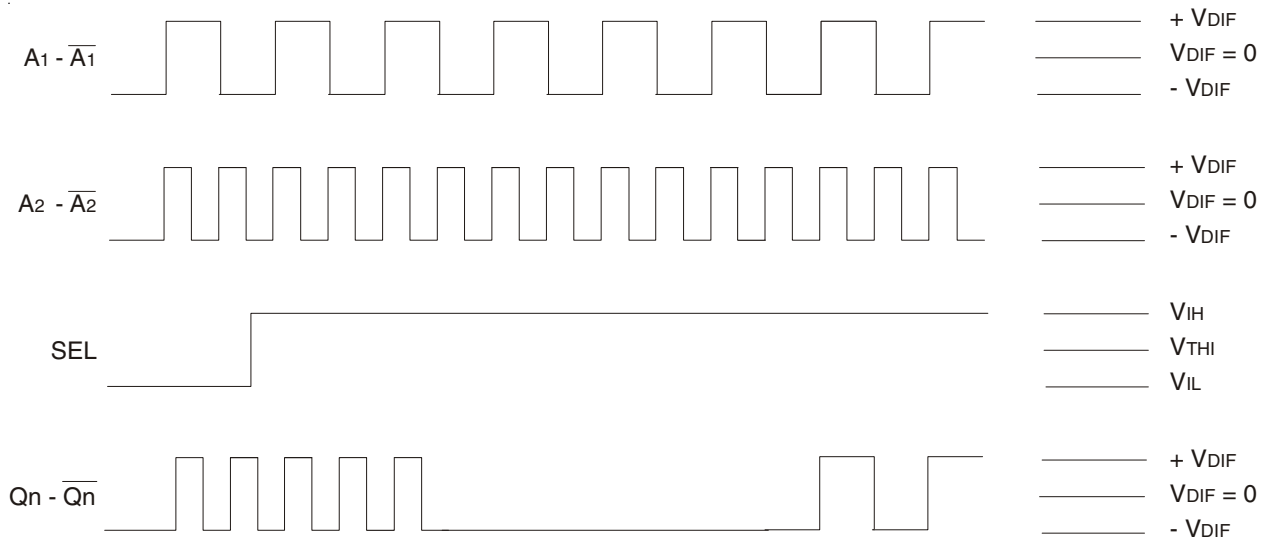

Glitchless Output Operation with Switching Input Clock Selection

NOTES:
1. When SEL changes, the output clock goes LOW on the falling edge of the output clock up to three cycles later. The output then stays LOW for up to three clock cycles of the new input clock. After this, the output starts with the rising edge of the new input clock.
2. AC propagation measurements should not be taken within the first 100 cycles of startup.

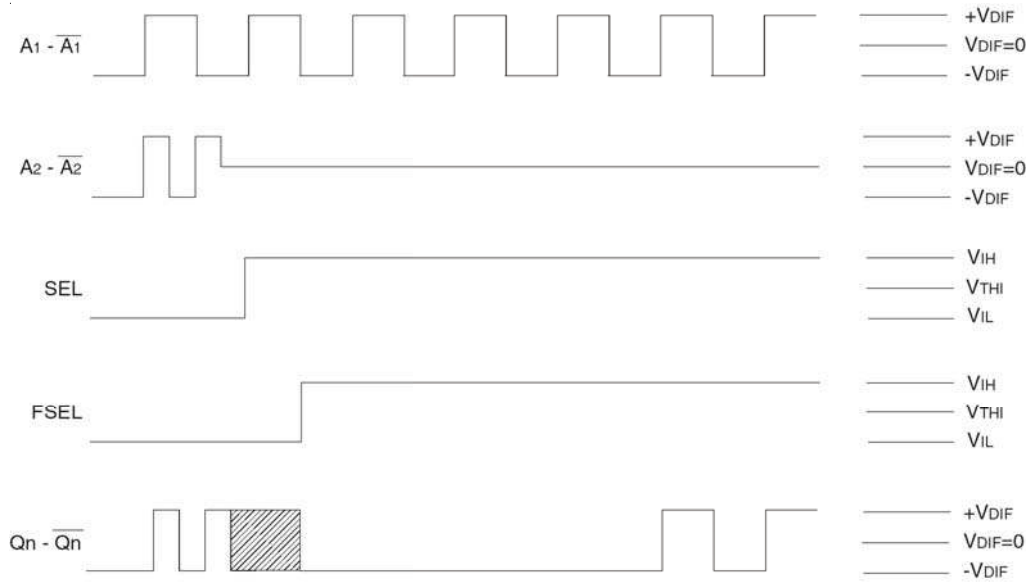

FSEL Operation for When Current Clock Dies

NOTES:

1. When the differential on the selected clock goes below the minimum DC differential, the outputs clock goes to an unknown state. When this happens, the SEL pin should be toggled and FSEL asserted in order to force selection of the new input clock. The output clock will start up after a number of cycles of the newly-selected input clock.
2. The FSEL pin should stay asserted until the problem with the dead clock can be fixed in the system.
3. It is recommended that the FSEL be tied HIGH for systems that use only one input. If this is not possible, the user must guarantee that the unused input have a differential greater than or equal to the minimum DC differential specified in the datasheet.

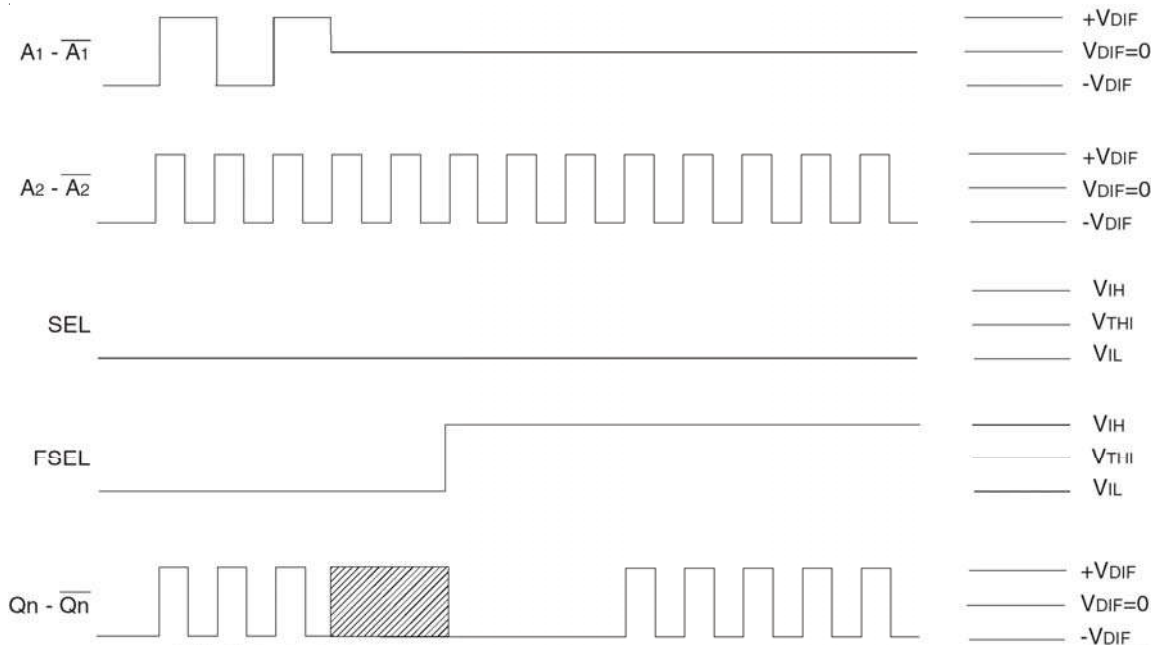

FSEL Operation for When Opposite Clock Dies

NOTES:

1. When the differential on the non-selected clock goes below the minimum DC differential, the outputs clock goes to an unknown state. When this happens, the FSEL pin should be asserted in order to force selection of the new input clock. The output clock will start up after a number of cycles of the newly-selected input clock.
2. The FSEL pin should stay asserted until the problem with the dead clock can be fixed in the system.
3. It is recommended that the FSEL be tied HIGH for systems that use only one input. If this is not possible, the user must guarantee that the unused input have a differential greater than or equal to the minimum DC differential specified in the datasheet.

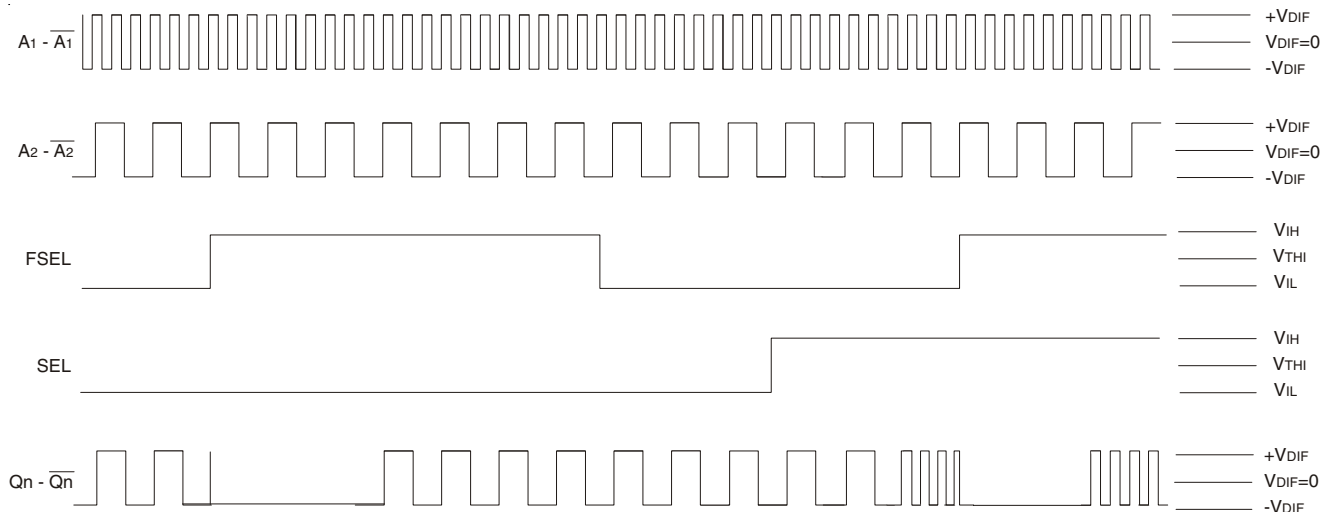

Selection of Input While Protecting Against When Opposite Clock Dies

NOTES:

1. If the user holds FSEL HIGH, the output will not be affected by the deselected input clock.
2. The output will immediately be driven to LOW once FSEL is asserted. This may cause glitching on the output. The output will restart with the input clock selected by the SEL pin.
3. If the user decides to switch input clocks, the user must de-assert FSEL, then assert FSEL after toggling the SEL input pin. The output will be driven LOW and will restart with the input clock selected by the SEL pin.

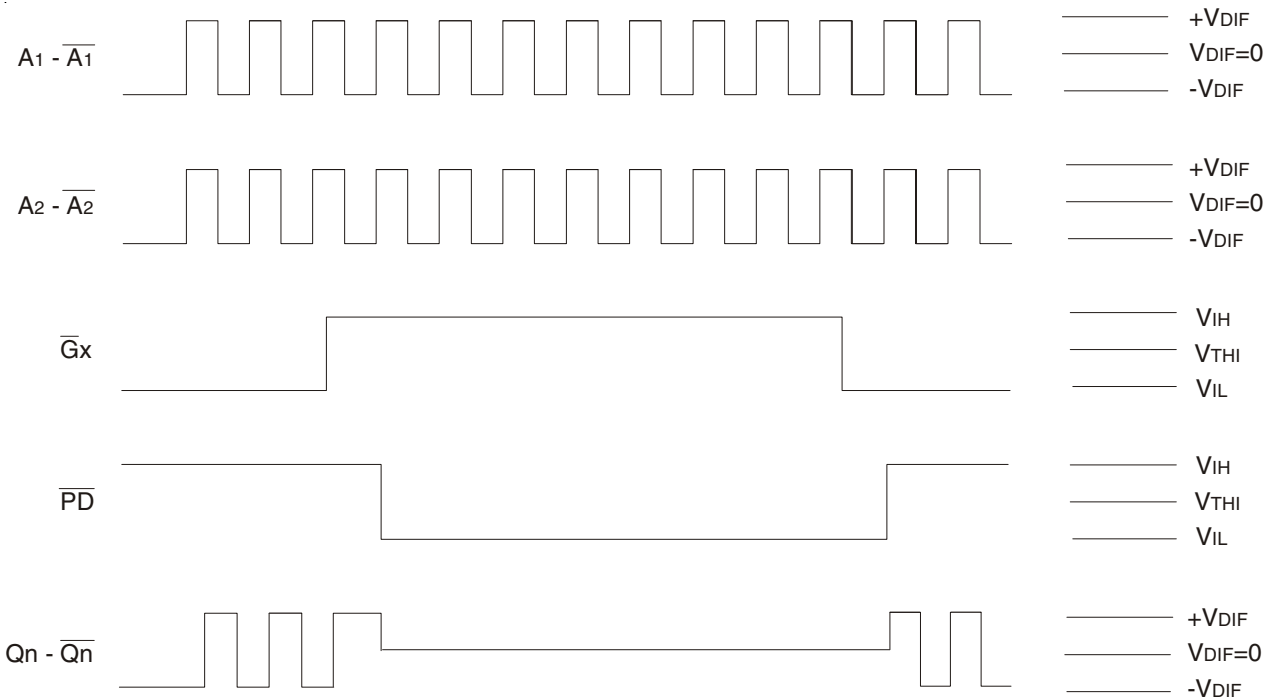

Power Down Timing

NOTES:

1. It is recommended that outputs be disabled before entering power-down mode. It is also recommended that the outputs remain disabled until the device completes power-up after asserting \overline{PD} .
2. The POWER DOWN TIMING diagram assumes that \overline{GL} is HIGH.
3. It should be noted that during power-down mode, the outputs are both pulled to V_{DD} . In the POWER DOWN TIMING diagram this is shown when $Q_n - \overline{Q_n}$ goes to $V_{DIF} = 0$.

TEST CIRCUITS AND CONDITIONS

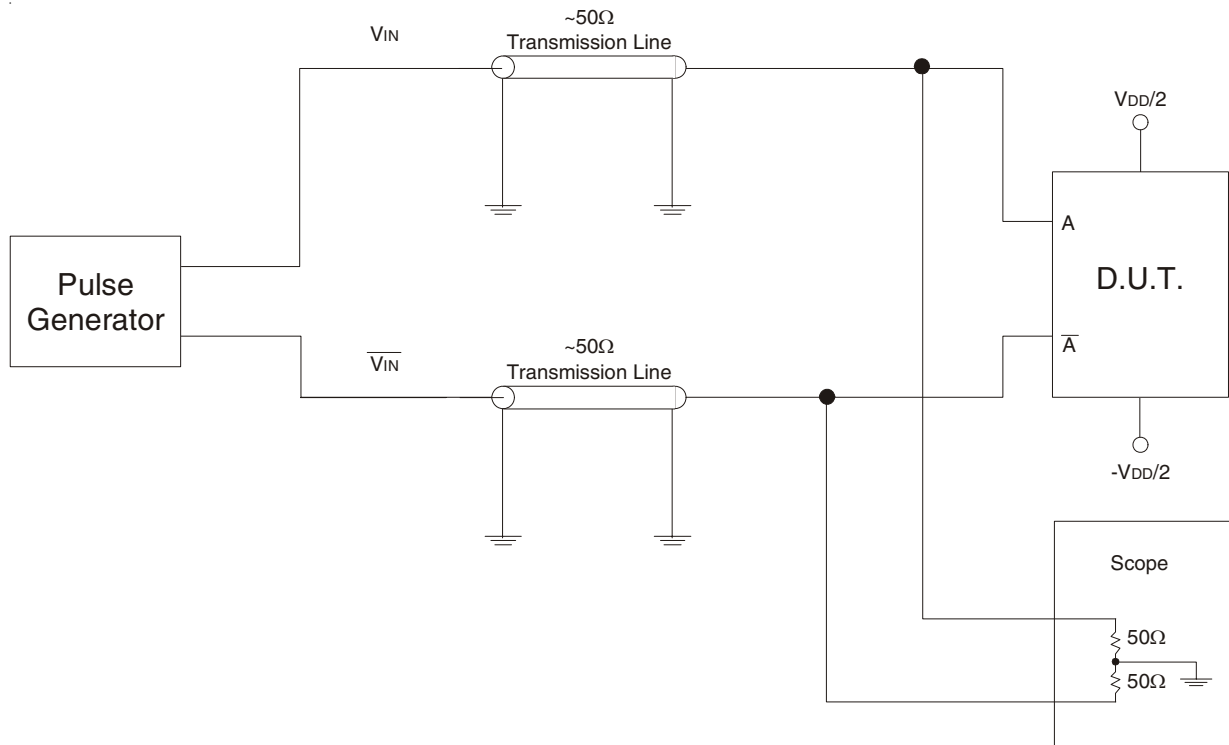

Test Circuit for Differential Input

DIFFERENTIAL INPUT TEST CONDITIONS

Symbol	$V_{DD} = 2.5V \pm 0.2V$	Unit
V_{THI}	Crossing of A and \overline{A}	V

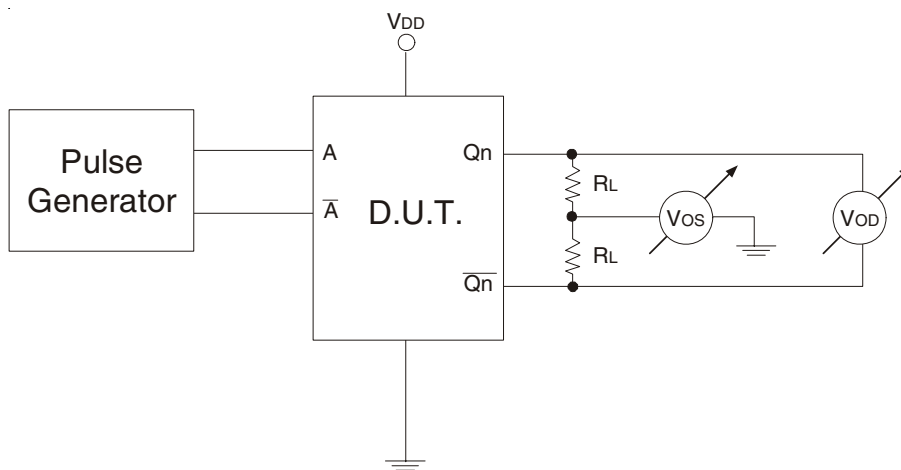

Test Circuit for DC Outputs and Power Down Tests

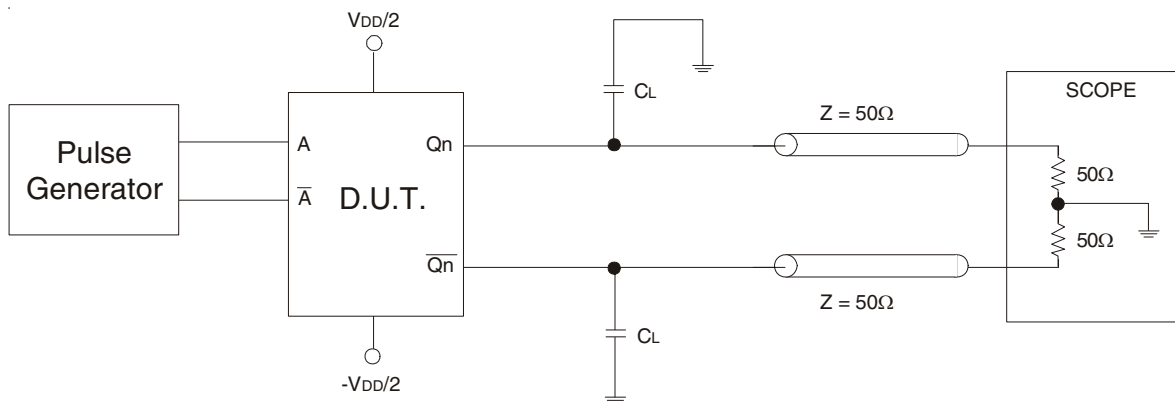

Test Circuit for Propagation, Skew, and Gate Enable/Disable Timing

LVDS OUTPUT TEST CONDITION

Symbol	$V_{DD} = 2.5V \pm 0.2V$	Unit
C_L	$0^{(1)}$	pF
	$8^{(1,2)}$	
R_L	50	Ω

NOTES:

1. Specifications only apply to "Normal Operations" test condition. The T_{IA}/E_{IA} specification load is for reference only.
2. The scope inputs are assumed to have a 2pF load to ground. T_{IA}/E_{IA} - 644 specifies 5pF between the output pair. With $C_L = 8pF$, this gives the test circuit appropriate 5pF equivalent load.

ORDERING INFORMATION

IDT	XXXXX	XX	X		
	Device Type	Package	Process		
			I		-40°C to +85°C (Industrial)
			PF PFG		Thin Quad Flat Pack TQFP - Green
			5T93GL101		2.5V LVDS 1:10 Glitchless Clock Buffer Terabuffer™ II



CORPORATE HEADQUARTERS
6024 Silver Creek Valley Road
San Jose, CA 95138

for SALES:
800-345-7015 or 408-284-8200
fax: 408-284-2775
www.idt.com

for Tech Support:
clockhelp@idt.com