

**STRAIGHT PLUG FULL CRIMP TYPE**

**R125.071.120**

**CABLE 2.6/50 S**

Series : SMA

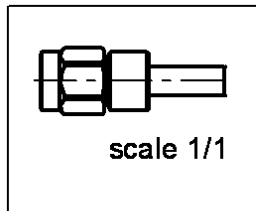
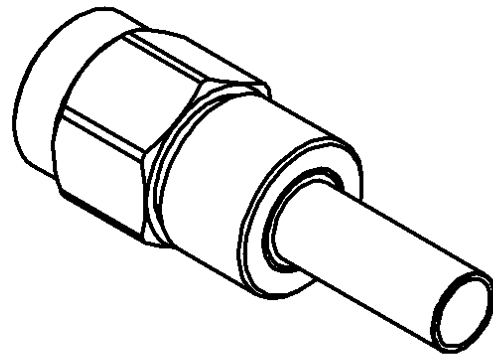
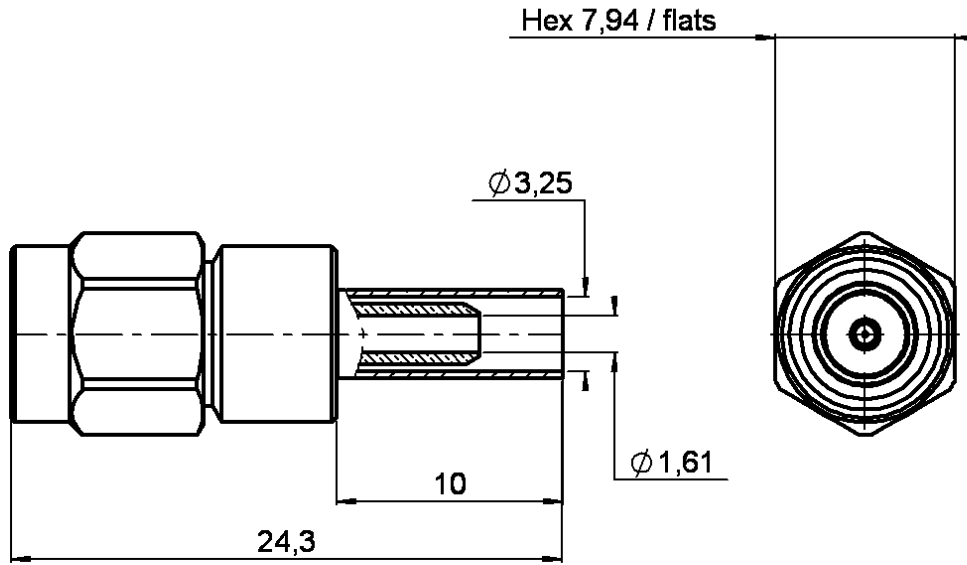

All dimensions are in mm.



COMPONENTS	MATERIALS	PLATING ( $\mu\text{m}$ )
BODY	STAINLESS STEEL	GOLD 0.5 OVER NICKEL 2
CENTER CONTACT	BRASS	GOLD 1.3 OVER NICKEL 2
OUTER CONTACT	-	-
INSULATOR	PTFE	-
GASKET	-	-
OTHERS PARTS	BRASS	GOLD 0.2 OVER NICKEL 2
-	-	-
-	-	-

Issue : 0315 A

In the effort to improve our products, we reserve the right to make changes judged to be necessary.



**STRAIGHT PLUG FULL CRIMP TYPE**

**R125.071.120**

**CABLE 2.6/50 S**

Series : SMA

**PACKAGING**

Standard	Unit	Other
<b>100</b>	<b>'W' option</b>	<b>Contact us</b>

**SPECIFICATION**

**ELECTRICAL CHARACTERISTICS**

Impedance		<b>50</b> Ω
Frequency		<b>0-12.4</b> GHz
VSWR	<b>1.15 +</b>	<b>0,0200</b> x F(GHz) Maxi
Insertion loss		<b>0.04</b> √F(GHz) dB Maxi
RF leakage	- (	- F(GHz)) dB Maxi
Voltage rating		<b>250</b> Veff Maxi
Dielectric withstanding voltage		<b>750</b> Veff mini
Insulation resistance		<b>5000</b> MΩ mini

**CABLE ASSEMBLY**

Stripping	a	b	c	d	e	f
mm	3,00	7,00	11,5	0,00	8,50	0,00

Assembly instruction : **Crimp 02**

Recommended cable(s)

- RG 188
- RG 316
- KX 22A
- RG 174
- RG 174 FTX
- KX 3B

Characteristics indicated on this data sheet are those that can be achieved with the highest performance cable. Intrinsic limitations of the cable may diminish the performance of the assembly

Cable retention

- pull off **90** N mini
- torque - N.cm

**MECHANICAL CHARACTERISTICS**

Center contact retention		
Axial force – Mating end	<b>18</b>	N mini
Axial force – Opposite end	<b>18</b>	N mini
Torque	<b>NA</b>	N.cm mini

Recommended torque		
Mating	<b>110</b>	N.cm
Panel nut	<b>NA</b>	N.cm
Clamp nut	<b>NA</b>	N.cm
A/F clamp nut	<b>0,0000</b>	mm

Mating life	<b>500</b>	Cycles mini
Weight	<b>4,2470</b>	g

**TOOLING**

Part Number	Description	Hexagon
.	.	.
<b>R282.235.003</b>	<b>CRIMPING DIES</b>	<b>3.25</b>
<b>R282.271.000</b>	<b>CRIMPING TOOL</b>	<b>3.25</b>
<b>R282.281.000</b>	<b>CRIMPING TOOL</b>	<b>2x4 pts</b>
<b>R282.293.000</b>	<b>CRIMPING TOOL</b> M22520/5-01	
<b>R282.967.012</b>	<b>POSITONER FOR</b> <b>CRIMPING TOOL</b>	

**ENVIRONMENTAL**

Operating temperature	<b>-65/+165</b>	°C
Hermetic seal	<b>NA</b>	Atm.cm3/s
Panel leakage	<b>NA</b>	

**OTHER CHARACTERISTICS**

Issue : 0315 A

In the effort to improve our products, we reserve the right to make changes judged to be necessary.

