

THIS DRAWING IS UNPUBLISHED. RELEASED FOR PUBLICATION
 © COPYRIGHT - - ALL RIGHTS RESERVED.

REVISIONS					
P	LTR	DESCRIPTION	DATE	DWN	APVD
F3		REVISED PER ECO-16-004223	16JUL2016	NK	MZ

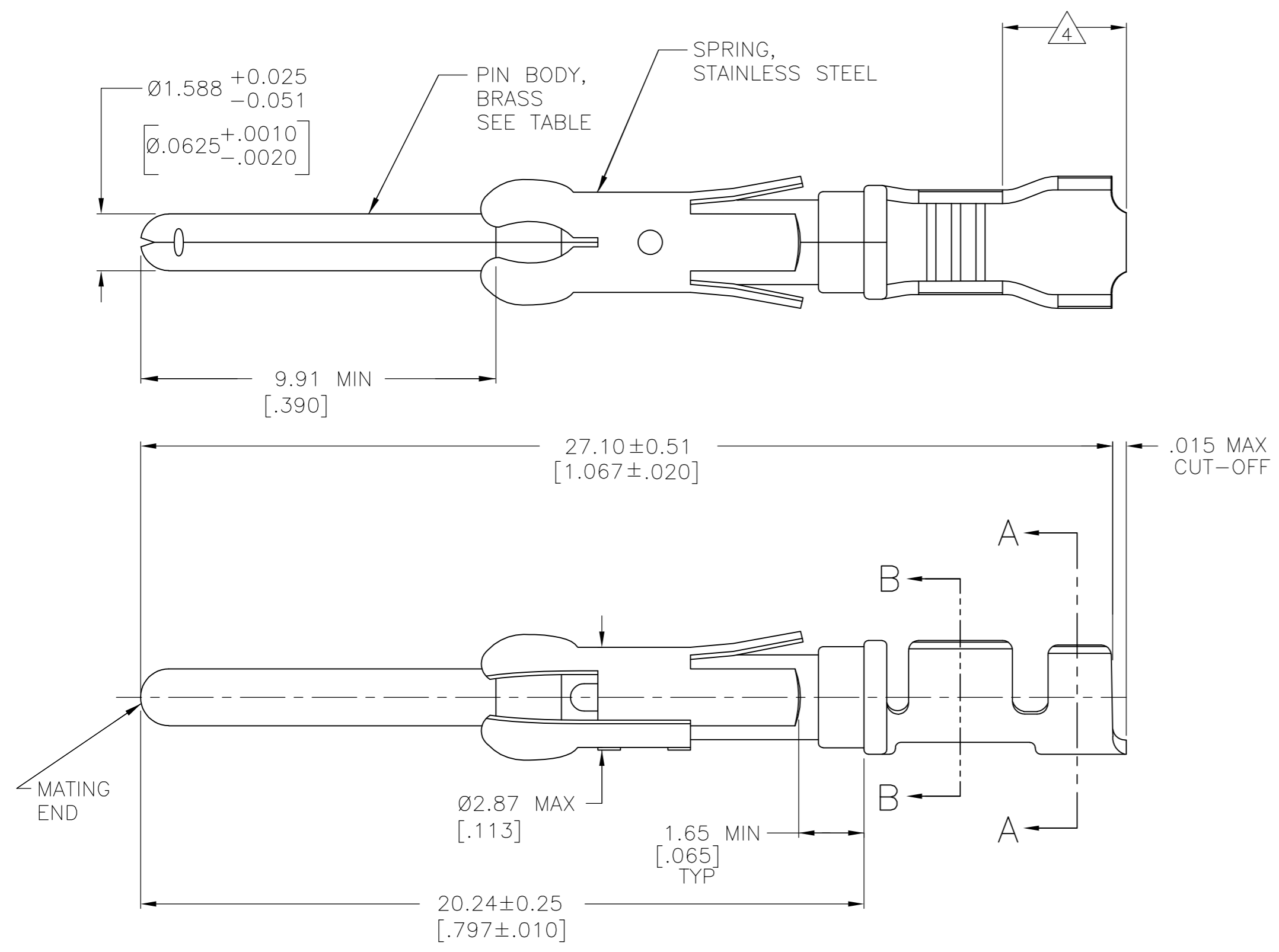

- 8 0.38µm [.000015] MIN GOLD PER MIL-G-45204 ON MATING END FOR A LENGTH OF 5.08 [.200] MIN, 1.27µm [.000050] MIN TIN-LEAD PER MIL-T-10727 ON OPPOSITE END FOR A LENGTH OF 5.69 [.224] MIN, BOTH OVER 1.27µm [.000050] MIN NICKEL PER QQ-N-290.
- 9 1.27µm [.000050] MIN TIN PER MIL-T-10727 OVER 1.27µm [.000050] MIN NICKEL PER QQ-N-290.

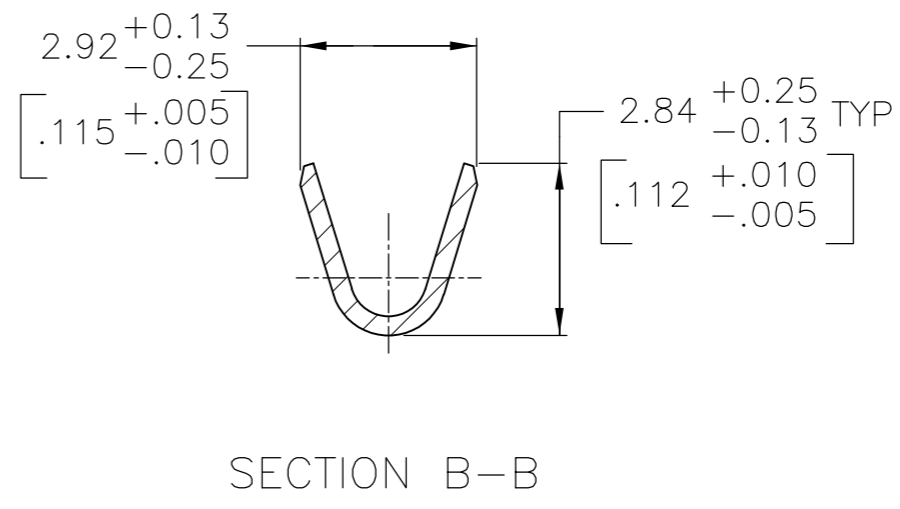
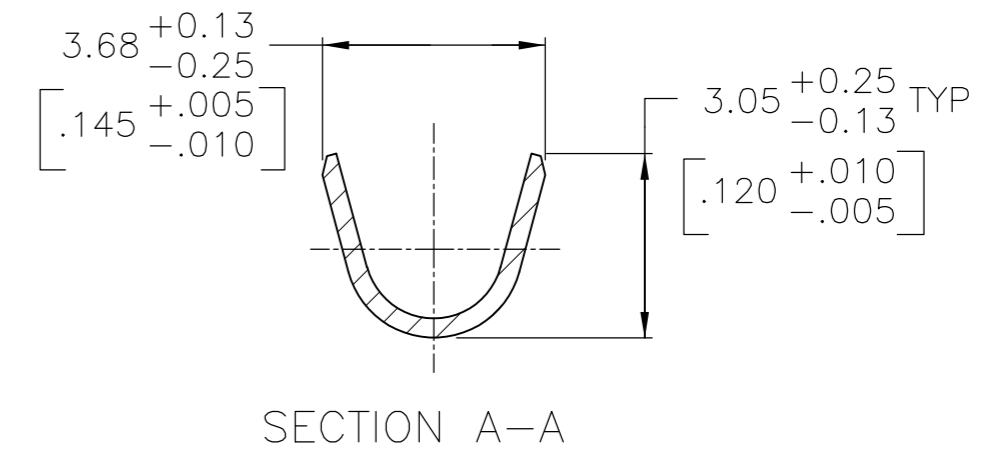

- 1 0.76µm [.000030] MIN PRECIOUS METAL PLATE ON MATING END FOR A LENGTH OF 5.08 [.200] MIN WITH 1.27µm [.000050] MIN MATTE TIN PLATE IN WIRE CRIMP AREA, BOTH OVER 1.27µm [.000050] MIN NICKEL PLATE. CONFORMS TO THE REQUIREMENTS OF TE PRODUCT SPEC 108-10042, BASED ON EIA/ECA-364-1000.01A (CONTROLLED ENVIRONMENT APPLICATIONS).
- 2 0.76µm [.000030] MIN PRECIOUS METAL PLATE ON MATING END FOR A LENGTH OF 5.08 [.200] MIN WITH A UNIFORM GRADIENT TO 0.25µm [.000010] ON REMAINDER, OVER 1.27µm [.000050] MIN NICKEL PLATE. GOLD FLASH ALL OVER. CONFORMS TO THE REQUIREMENTS OF TE PRODUCT SPEC 108-10042, BASED ON EIA/ECA-364-1000.01A (CONTROLLED ENVIRONMENT APPLICATIONS).
- 3 0.38µm [.000015] MIN GOLD PER MIL-G-45204 ON MATING END FOR A LENGTH OF 5.08 [.200] MIN WITH 1.27µm [.000050] MIN MATTE TIN PLATE IN WIRE CRIMP AREA, BOTH OVER 1.27µm [.000050] MIN NICKEL PER QQ-N-290.
- 4 GOLD PLATING NOT REQUIRED IN THIS AREA.
- 5 1.27µm [.000050] MIN TIN-LEAD PER MIL-T-10727 OVER 1.27µm [.000050] MIN NICKEL PER QQ-N-290.
- 6 ALL CONTACTS ON THIS DRAWING CAPABLE OF BEING USED WITH:
 A WIRE RANGE OF 18-16 AWG WITH AN INSULATION RANGE OF Ø2.03-2.54 [.080-.100] OR
 A WIRE SIZE OF 0.75mm² WITH AN INSULATION RANGE OF Ø1.35-1.65 [.053-.065] OR
 A WIRE SIZE OF 1.0mm² WITH AN INSULATION RANGE OF Ø1.45-1.80 [.057-.071].

PACKAGING TYPE	CONTACT FINISH	STRIP P/N REF	PART NO
SMALL PACK	9	1-66098-8 OR 1-66098-9	1-66099-6
STANDARD	9	1-66098-8 OR 1-66098-9	1-66099-5
SMALL PACK	1	66098-4	1-66099-4
SMALL PACK	3	66098-3	1-66099-3
SMALL PACK	5	66098-2	1-66099-2
SMALL PACK	2	66098-1	1-66099-1
STANDARD	8	1-66098-6	1-66099-0
STANDARD	1	66098-4	66099-4
STANDARD	3	66098-3	66099-3
STANDARD	5	66098-2	66099-2
STANDARD	2	66098-1	66099-1

OBSOLETE
 SUPERSEDED BY 66099-3

THIS DRAWING IS A CONTROLLED DOCUMENT.

DWN	05/29/92	L.SIPE	
CHK	6-11-92	W.LENKER	
APVD	7-7-92	G.STEINHAUER	
PRODUCT SPEC		-	
APPLICATION SPEC		-	
WEIGHT	-	SIZE	A2
CUSTOMER DRAWING		CAGE CODE	00779
		DRAWING NO	C=66099
		RESTRICTED TO	-
		SCALE	8:1
		SHEET	1 OF 1
		REV	F3

TE Connectivity
 PIN ASSEMBLY, LOOSE PIECE, TYPE III+