

# High Efficiency Audio Subsystem

## ISL99203

The ISL99203 is a fully integrated high efficiency class-D mono amplifier combined with a capfree headphone amplifier. It is designed to maximize performance for mobile phone applications while saving valuable board space. The application circuit requires a minimum requirement of external components and operates from a 2.4V to 5.5V input supply.

It is capable of delivering 1.5W of continuous output power with less than 10% THD+N driving a 8Ω load from a 5V supply. The speaker amplifier of the ISL99203 features a high-efficiency, low-noise modulation scheme. It operates with 85% efficiency at 400mW into 8Ω from 5V supply and has a signal-to-noise ratio (SNR) that is greater than 95dB. The architecture of the device allows it to achieve very low level pop and click. This minimizes voltage glitches at the output during turn-on and turn-off, thus reducing audible noise on activation and deactivation. EMI suppression is achieved by SRC (Slew Rate Control). The amplifier passes FCC Radiated Emissions Standards with 24 inches of Cable and achieves greater than 20dB margin under FCC limits.

The class-D amplifier is designed to operate without a low pass output filter thus saving cost and board space. The headphone amplifier is a GND-reference capfree amplifier. It can output up to 35mW into 32Ω at 3.3V.

## Features

- Operating Voltage 2.4V to 5.5V
- Low Quiescent Current
- Low Shutdown Current
- Low RFI Susceptibility
- Integrated Bypass Switch, I<sup>2</sup>C Controlled
- I<sup>2</sup>C Control Interface
- 40 Step Digital Volume Control
- 3 Independent Volume Channels
- 10 Distinct Output Modes
- Speaker Amp Class-D
- Protection for UV/TSD/OC
- Independent Gain Boost for Headphone and Speaker
- All Digital Interfaces 1.8V Compatible
- Exposed Pad at Ground Voltage

## Applications\* (see page 15)

- Mobile Phones
- PDAs
- Portable Media Players
- Portable Gaming

### Total Harmonic Distortion Plus Noise vs Power (Mono)

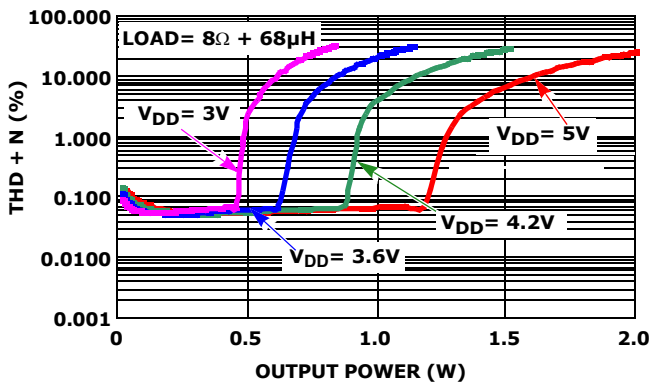

### Total Harmonic Distortion Plus Noise vs Power (Headphone)

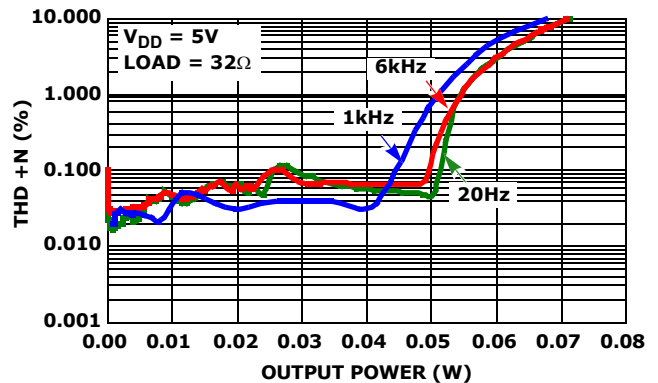

## Pin Configurations

ISL99203  
(20 BALL WLCSP)  
BOTTOM VIEW

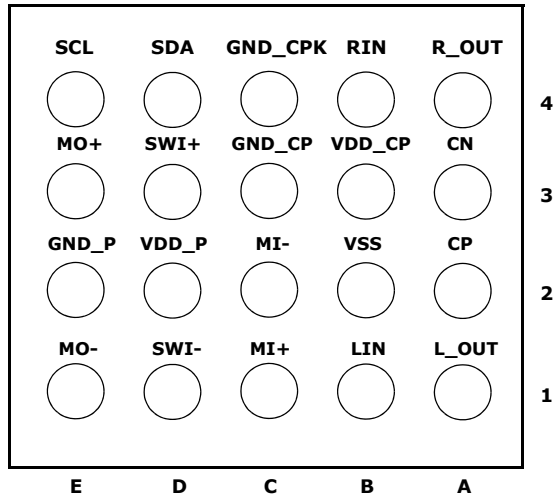

ISL99203  
(20 BALL WLCSP)  
TOP VIEW

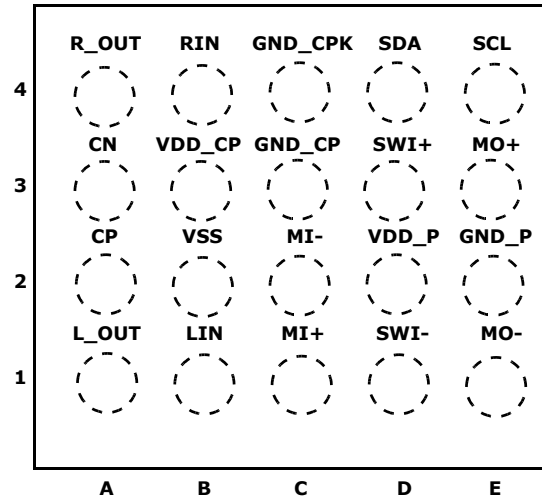

## Pin Descriptions

20 BUMP CSP	PIN NAME	PIN DESCRIPTION
C4	GND_CPK	Charge-Pump Ground
A1	L_OUT	Left Headphone Out
B2	VSS	Negative-Power Supply
A2	CP	Charge-Pump Cap +
A3	CN	Charge-Pump Cap -
A4	R_OUT	Right Headphone Out
B4	RIN	Right Input Channel
B3	VDD_CP	Charge-Pump Power Supply
C3	GND_CP	Charge-Pump Ground
D4	SDA	I <sup>2</sup> C Data
D3	SWI+	Switch Input +
E4	SCL	I <sup>2</sup> C Clock
E3	MO+	Mono O/P Positive
D2	VDD_P	Power Supply
E2	GND_P	Power Ground
E1	MO-	Mono O/P Negative
D1	SWI-	Switch Input -
C1	MI+	Mono Positive Input
C2	MI-	Mono Negative Input
B1	LIN	Left input Channel

## Ordering Information

PART NUMBER (Notes 1, 2, 3)	PART MARKING	TEMP RANGE (°C)	PACKAGE (Pb-free)	PKG. DWG. #
ISL99203IIZ-T	203	-40 to +85	20 Ball WLCSP	W4x5.20

### NOTES:

- Please refer to [TB347](#) for details on reel specifications.
- These Intersil Pb-free WLCSP and BGA packaged products employ special Pb-free material sets; molding compounds/die attach materials and SnAgCu - e1 solder ball terminals, which are RoHS compliant and compatible with both SnPb and Pb-free soldering operations. Intersil Pb-free WLCSP and BGA packaged products are MSL classified at Pb-free peak reflow temperatures that meet or exceed the Pb-free requirements of IPC/JEDEC J STD-020.
- For Moisture Sensitivity Level (MSL), please see device information page for [ISL99203](#). For more information on MSL please see tech brief [TB363](#).

Typical Application

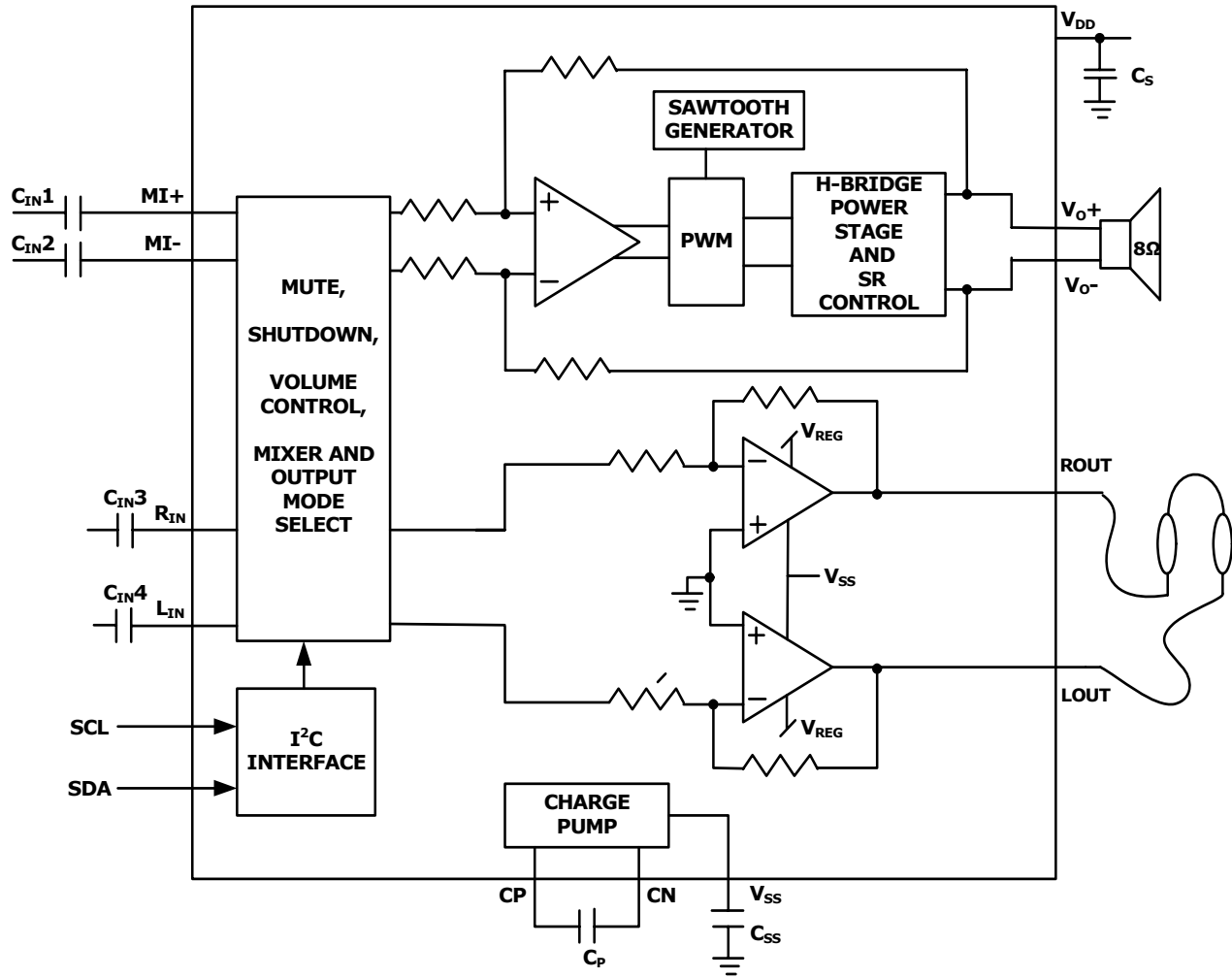

# Block Diagram

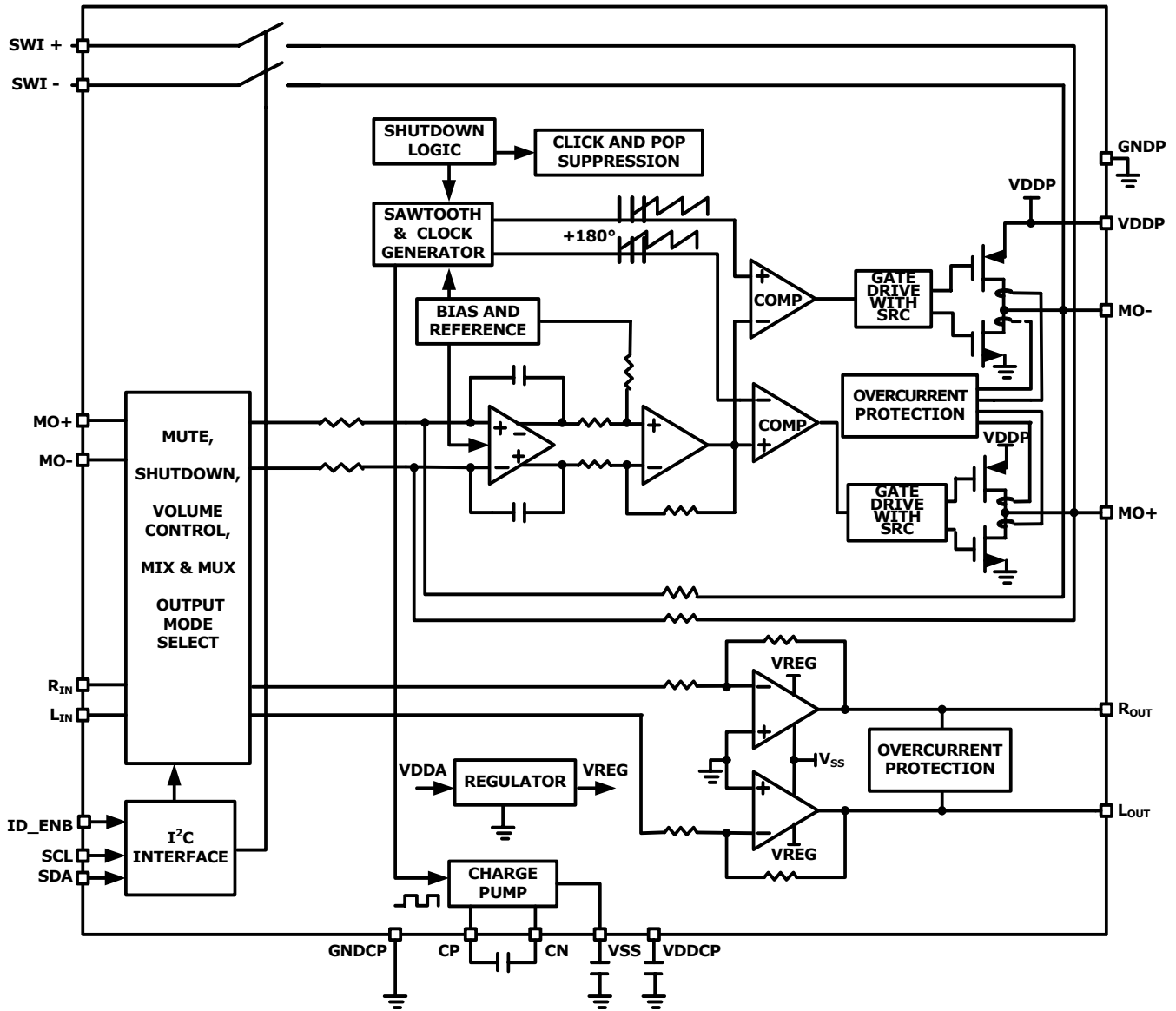

# ISL99203

## Absolute Maximum Ratings (Reference to GND)

Supply Voltage	-0.3V to 6V
LIN, RIN, MI+, MI-, SWI+, SWI-	-0.3V to V <sub>DD</sub> +0.3V
ESD Ratings	
Human Body Model	2kV
Machine Model	250V
Charged Device Model	1500V

## Recommended Operating Conditions

Ambient Temperature Range	-40°C to +85°C
Operating Supply Voltage (VDD Pin)	2.4V to 5.5V

## Thermal Information

Thermal Resistance (Typical, Note 4)	$\theta_{JA}$ (°C/W)
WLCSP Package	71
Maximum Junction Temperature (Plastic Package)	
Maximum Storage Temperature Range	-65°C to +150°C
Dissipation Ratings	
Derating Factor	
20 Balls 4x5 Array WLCSP	10.1mW/°C
Power Rating T <sub>A</sub>	
20 Balls 4x5 Array WLCSP	
+25°C	1.76W
+70°C	1.12W
+85°C	0.91W
Pb-Free Reflow Profile	
see link below	
<a href="http://www.intersil.com/pbfree/Pb-FreeReflow.asp">http://www.intersil.com/pbfree/Pb-FreeReflow.asp</a>	

**CAUTION:** Do not operate at or near the maximum ratings listed for extended periods of time. Exposure to such conditions may adversely impact product reliability and result in failures not covered by warranty.

### NOTE:

- $\theta_{JA}$  is measured with the component mounted on a high effective thermal conductivity test board in free air. See Tech Brief TB379 for details.

**Electrical Specifications** V<sub>DD</sub> = 3.6V. Typical Values Are Tested at V<sub>DD</sub> = 3.6V and the Ambient Temperature at +25°C. All Maximum and Minimum Values Are Established Under the Recommended Operating Supply Voltage Range and Ambient Temperature, Unless Otherwise Noted.

PARAMETER	SYMBOL	TEST CONDITIONS	MIN	TYP	MAX	UNITS
Output Power	P <sub>OUT</sub>	Mono, R <sub>L</sub> = 8Ω, THD = 1%, f = 1kHz, BTL, mode 1		740		mW
		Mono, R <sub>L</sub> = 8Ω, THD = 10%, f = 1kHz, BTL, mode 1		925		mW
		Headphone out R <sub>L</sub> = 32Ω, THD = 1%, f = 1kHz, mode 4		47		mW
		Headphone out R <sub>L</sub> = 32Ω, THD = 10%, f = 1kHz, mode 4		62		mW
Total Harmonic Distortion	THD+N	A-weighted, grounded inputs and output referred				
		Mono, R <sub>L</sub> = 8Ω, f = 1kHz, BTL, P <sub>OUT</sub> = 500mW, mode 1		0.05		%
		Headphone out, R <sub>L</sub> = 32Ω, f = 1kHz, P <sub>OUT</sub> = 50mW, mode 4		0.01		%
Output Offset Voltage	V <sub>OS</sub>	V <sub>IN</sub> = 0V, mode 1, Mono		2		mV
		V <sub>IN</sub> = 0V, mode 4 Headphones		0.2		mV
Quiescent Current	I <sub>qq</sub>	O/P modes 2, 4, 6, V <sub>IN</sub> = 0V, no load		4.5	6	mA
		O/P modes 1, 3, 5, 7, V <sub>IN</sub> = 0V, no load		6.5	8	mA
Shutdown Current	I <sub>SD</sub>	Output mode 0		0.01	0.5	μA
Digital Volume Control Range		Max Gain		18		dB
HP Mute Attenuation				96		dB
Input Impedance (Mono and HP)				12.5		kΩ
Average Switching Frequency	f <sub>SW</sub>	Output mode 1, V <sub>DD</sub> = 3.6V	250	325	400	kHz
Power Supply Rejection Ratio	PSRR-Mono	V <sub>RIPPLE</sub> = 200mV, f = 217Hz, R <sub>L</sub> = 8Ω, all inputs at GND, O/P mode 1		75		dB
	PSRR-HP	V <sub>RIPPLE</sub> = 200mV, f = 217Hz, R <sub>L</sub> = 32Ω, all inputs at GND, O/P mode 4		85		dB
Common Mode Rejection Ratio	CMRR	f = 217Hz, V <sub>cm</sub> = 1V <sub>P-P</sub> 0dB, mode 1, R <sub>L</sub> = 8Ω		61		dB
		f = 217Hz, V <sub>cm</sub> = 1V <sub>P-P</sub> 0dB, mode 2, R <sub>L</sub> = 32Ω		66		dB

# ISL99203

**Electrical Specifications**  $V_{DD} = 3.6V$ . Typical Values Are Tested at  $V_{DD} = 3.6V$  and the Ambient Temperature at  $+25^{\circ}C$ . All Maximum and Minimum Values Are Established Under the Recommended Operating Supply Voltage Range and Ambient Temperature, Unless Otherwise Noted. **(Continued)**

PARAMETER	SYMBOL	TEST CONDITIONS	MIN	TYP	MAX	UNITS
<b>PROTECTION</b>						
Thermal Shutdown				145		$^{\circ}C$
Thermal Shutdown Hysteresis				30		$^{\circ}C$
Overcurrent Shutdown		Mono		1.3		A
		HP		200		mA
Undervoltage Shutdown					2.4	V
Wake-up Time from Shutdown	$t_{WU}$			3.5		ms
<b>NOISE PERFORMANCE</b>						
Output Voltage Noise	$e_n$	Mono, mode 1		33		$\mu V$
		HP, mode 4, 7		12		$\mu V$

**Electrical Specifications**  $V_{DD} = 5V$ . Typical Values Are Tested at  $V_{DD} = 5V$  and the Ambient Temperature at  $+25^{\circ}C$ . All Maximum and Minimum Values Are Established Under the Recommended Operating Supply Voltage Range and Ambient Temperature, Unless Otherwise Noted.

PARAMETER	SYMBOL	TEST CONDITIONS	MIN	TYP	MAX	UNITS
Output Power	$P_{OUT}$	Mono, $R_L = 8\Omega$ , THD = 1%, $f = 1kHz$ , BTL, Mode 1		1		W
		Mono, $R_L = 8\Omega$ , THD = 10%, $f = 1kHz$ , BTL, Mode 1		1.375		W
		Headphone out $R_L = 32\Omega$ , THD = 1%, $f = 1kHz$ , SE, Mode 4		47		mW
		Headphone out $R_L = 32\Omega$ , THD = 10%, $f = 1kHz$ , SE, Mode 4		62		mW
Total Harmonic Distortion	THD+N	A-weighted, grounded inputs and output referred				
		Mono, $R_L = 8\Omega$ , $f = 1kHz$ , BTL, $P_{OUT} = 500mW$ , Mode 1		0.05		%
		Headphone out, $R_L = 32\Omega$ , $f = 1kHz$ , $P_{OUT} = 50mW$ , Mode 4		0.01		%
Output Offset Voltage	$V_{OS}$	$V_{IN} = 0V$ , mode 1, Mono		2		mV
		$V_{IN} = 0V$ , mode 4 Headphones		0.2		mV
Quiescent Current	$I_{qq}$	O/P modes 4		5		mA
		O/P modes 1		5.5		mA
Shutdown Current	$I_{SD}$	Output mode 0		0.01		$\mu A$
Digital Volume Control Range		Max Gain		18		dB
HP Mute Attenuation				96		dB
Input Impedance (Mono and HP)				12.5		$k\Omega$
Power Supply Rejection Ratio	PSRR-Mono	$V_{Ripple} = 200mV$ , $f = 217Hz$ , $R_L = 8\Omega$ , all inputs at GND, O/P mode 1		75		dB
	PSRR-HP	$V_{Ripple} = 200mV$ , $f = 217Hz$ , $R_L = 32\Omega$ , all inputs at GND, O/P mode 4, 7		85		dB
Common Mode rejection Ratio	CMRR	$f = 217Hz$ , $V_{cm} = 1V_{P-P}$ 0dB, mode 1, $R_L = 8\Omega$		61		dB
		$f = 217Hz$ , $V_{cm} = 1V_{P-P}$ 0dB, mode 2, $R_L = 32\Omega$		66		dB

# ISL99203

**Electrical Specifications**  $V_{DD} = 5V$ . Typical Values Are Tested at  $V_{DD} = 5V$  and the Ambient Temperature at  $+25^{\circ}C$ . All Maximum and Minimum Values Are Established Under the Recommended Operating Supply Voltage Range and Ambient Temperature, Unless Otherwise Noted. **(Continued)**

PARAMETER	SYMBOL	TEST CONDITIONS	MIN	TYP	MAX	UNITS
<b>PROTECTION</b>						
Thermal Shutdown				145		$^{\circ}C$
Thermal Shutdown Hysteresis				30		$^{\circ}C$
Overcurrent Shutdown		Mono		1.3		A
		HP		200		mA
Undervoltage Shutdown					2.4	V
Wake-up Time from Shutdown	$t_{WU}$			3.5		ms
<b>NOISE PERFORMANCE</b>						
Output Voltage Noise	$e_n$	Mono, Mode 1		33		$\mu V$
		HP, Mode 4, 7		12		$\mu V$

## SDA vs SCL Timing

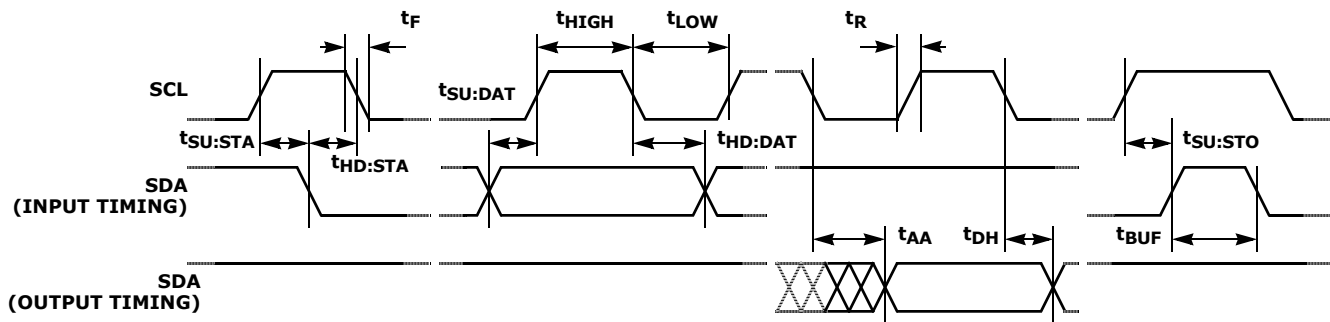

**TABLE 1. CHIP ADDRESS**

	A7	A6	A5	A4	A3	A2	A1	A0
Chip Address	1	1	1	1	1	0	Pin Controlled	0
ID_ENB = 0	1	1	1	1	1	0	0	0
ID_ENB = 1	1	1	1	1	1	0	1	0

**TABLE 2. CONTROL REGISTERS**

	D7	D6	D5	D4	D3	D2	D1	D0
Mode Control	0	0	0/1	0	X/MC3	MC2	MC1	MC0
Boost Control	0	1	1	X	Amp BYP	GBM	GBHPL	GBHPR
Mono Volume Control	1	0	0	MVC4	MVC3	MVC2	MVC1	MVC0
Extended Volume Control	1	0	1	0	0	RVC5	LVC5	MVC5
Left Volume Control	1	1	0	LVC4	LVC3	LVC2	LVC1	LVC0
Right Volume Control	1	1	1	RVC4	RVC3	RVC2	RVC1	RVC0

NOTE: GBM: Gain Boost on Mono Speaker; 0 = no boost, 1 = 3dB  
 GBHP: Gain Boost on Headphone; 0 = no boost, 1 = 3dB  
 Amp Bypass: 0 is no bypass (Switch OFF); 1 is bypass (Switch ON)

# ISL99203

**TABLE 3. OUTPUT MODES**

OUTPUT MODE	MC3	MC2	MC1	MC0	SPEAKER OUTPUT	RIGHT HP OUTPUT	LEFT HP OUTPUT
0	0	0	0	0	SD	SD	SD
1	0	0	0	1	$G_M \times M$	SD	SD
2	0	0	1	0	SD	$G_M \times M/2$	$G_M \times M/2$
3	0	0	1	1	$2 \times (G_L \times L + G_R \times R)$	SD	SD
4	0	1	0	0	SD	$G_R \times R$	$G_L \times L$
5	0	1	0	1	$2 \times (G_L \times L + G_R \times R) + G_M \times M$	SD	SD
6	0	1	1	0	SD	$G_M \times M/2 + G_R \times R$	$G_M \times M/2 + G_L \times L$
7	0	1	1	1	$2 \times (G_L \times L + G_R \times R)$	$G_R \times R$	$G_L \times L$
10	1	0	1	0	$2 \times (G_L \times L + G_R \times R)$	$G_M \times M/2$	$G_M \times M/2$
14	1	1	1	0	$2 \times (G_L \times L + G_R \times R)$	$G_M \times M/2 + G_R \times R$	$G_M \times M/2 + G_L \times L$

**NOTE:**

Power On Default Mode 0 0 0 0

M = Mono, Phone in

R =  $R_{IN}$

L =  $L_{IN}$

SD = Shutdown

GM = Mono Volume Control gain

GR = Right HP Volume Control Gain

GL = Left HP Volume Control gain

**TABLE 4. VOLUME CONTROL**

VOLUME STEP	VC5	VC4	VC3	VC2	VC1	VC0	GAIN (dB)
0	0	0	0	0	0	0	-82
1	0	0	0	0	0	1	-76
2	0	0	0	0	1	0	-70
3	0	0	0	0	1	1	-64.5
4	0	0	0	1	0	0	-58.5
5	0	0	0	1	0	1	-52
6	0	0	0	1	1	0	-46.5
7	0	0	0	1	1	1	-40.5
8	0	0	1	0	0	0	-34.5
9	0	0	1	0	0	1	-30
10	0	0	1	0	1	0	-26.5
11	0	0	1	0	1	1	-24
12	0	0	1	1	0	0	-21
13	0	0	1	1	0	1	-18
14	0	0	1	1	1	0	-15
15	0	0	0	1	1	1	-13.5
16	0	1	0	0	0	0	-11.5
17	0	1	0	0	0	1	-10
18	0	1	0	0	1	0	-8.5
19	0	1	0	0	1	1	-7
20	0	1	0	1	0	0	-6



# ISL99203

TABLE 4. VOLUME CONTROL (Continued)

VOLUME STEP	VC5	VC4	VC3	VC2	VC1	VC0	GAIN (dB)
21	0	1	0	1	0	1	-4.5
22	0	1	0	1	1	0	-3
23	0	1	0	1	1	1	-1.5
24	0	1	1	0	0	0	0
25	0	1	1	0	0	1	1.5
26	0	1	1	0	1	0	3
27	0	1	1	0	1	1	4.5
28	0	1	1	1	0	0	6
29	0	1	1	1	0	1	7.5
30	0	1	1	1	1	0	9
31	0	0	1	1	1	1	10.5
32	1	0	0	0	0	0	12
33	1	0	0	0	0	1	12.75
34	1	0	0	0	1	0	13.5
35	1	0	0	0	1	1	14.25
36	1	0	0	1	0	0	15
37	1	0	0	1	0	1	15.75
38	1	0	0	1	1	0	16.5
39	1	0	0	1	1	1	17.25
40	1	0	1	0	0	0	18

## Typical Performance Characteristics

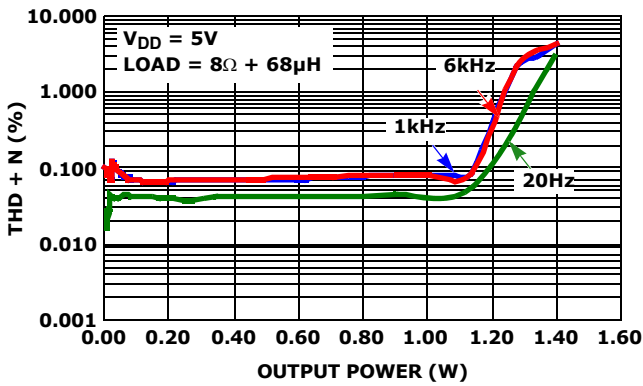

FIGURE 1. TOTAL HARMONIC DISTORTION PLUS NOISE vs POWER (MONO)

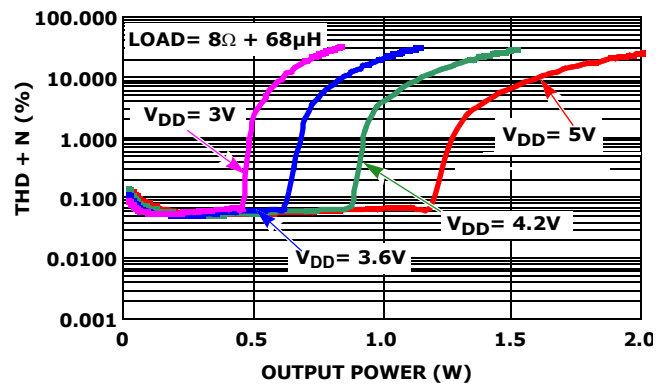

FIGURE 2. TOTAL HARMONIC DISTORTION PLUS NOISE vs POWER (MONO)

Typical Performance Characteristics (Continued)

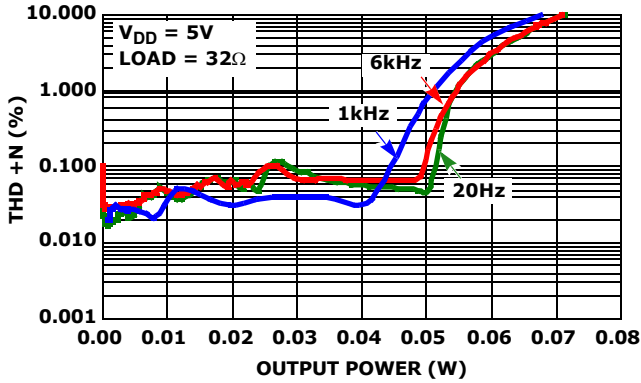

FIGURE 3. TOTAL HARMORNIC DISTORTION PLUS NOISE vs POWER (HEADPHONE)

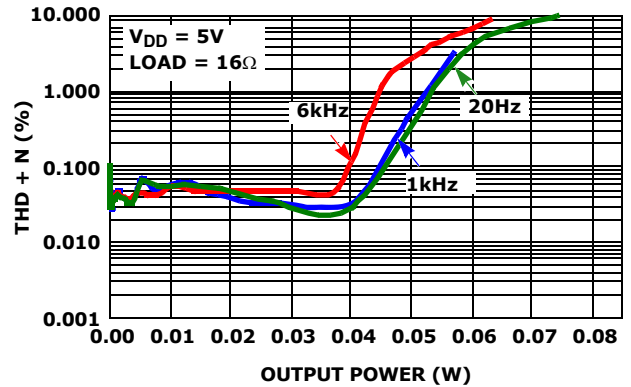

FIGURE 4. TOTAL HARMORNIC DISTORTION PLUS NOISE vs POWER (HEADPHONE)

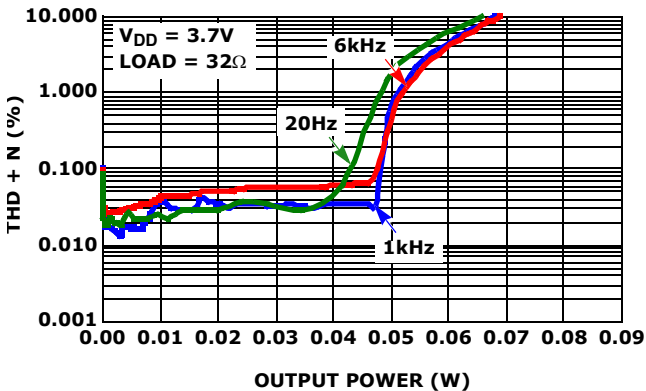

FIGURE 5. TOTAL HARMORNIC DISTORTION PLUS NOISE vs POWER (HEADPHONE)

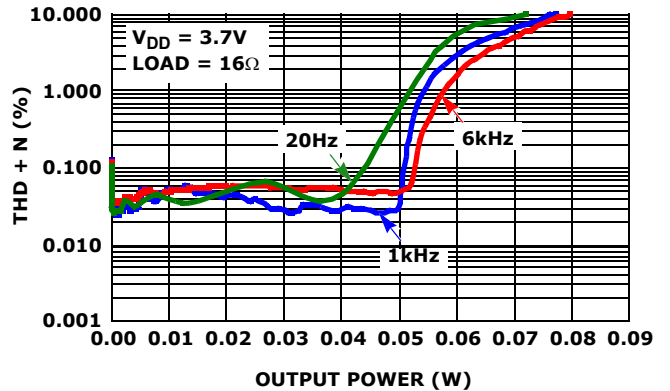

FIGURE 6. TOTAL HARMORNIC DISTORTION PLUS NOISE vs POWER (HEADPHONE)

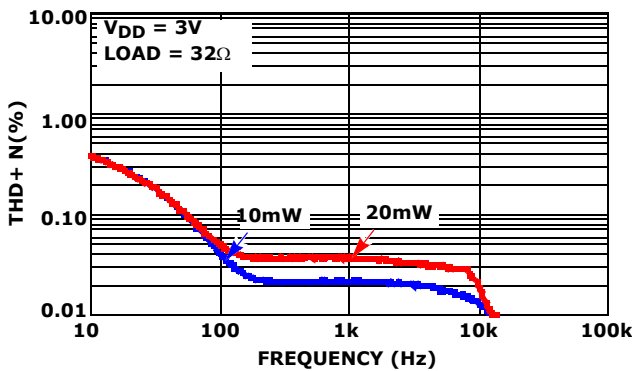

FIGURE 7. TOTAL HARMORNIC DISTORTION PLUS NOISE vs FREQUENCY (HEADPHONE)

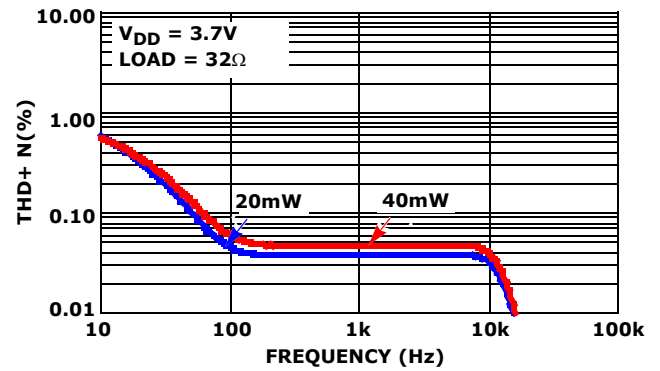

FIGURE 8. TOTAL HARMORNIC DISTORTION PLUS NOISE vs FREQUENCY (HEADPHONE)

Typical Performance Characteristics (Continued)

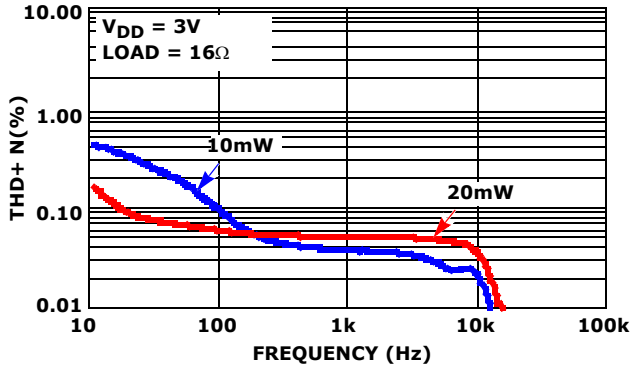

FIGURE 9. TOTAL HARMONIC DISTORTION PLUS NOISE vs FREQUENCY (HEADPHONE)

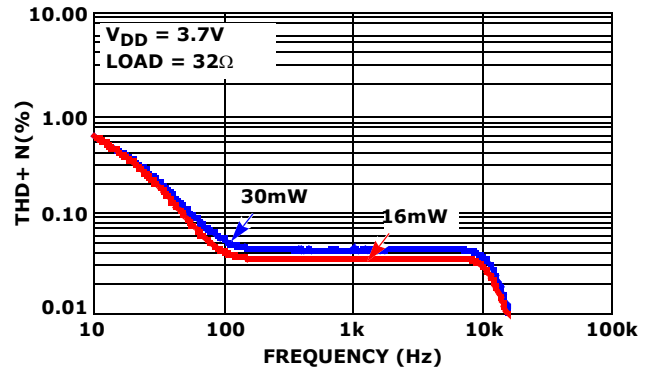

FIGURE 10. TOTAL HARMONIC DISTORTION PLUS NOISE vs FREQUENCY (HEADPHONE)

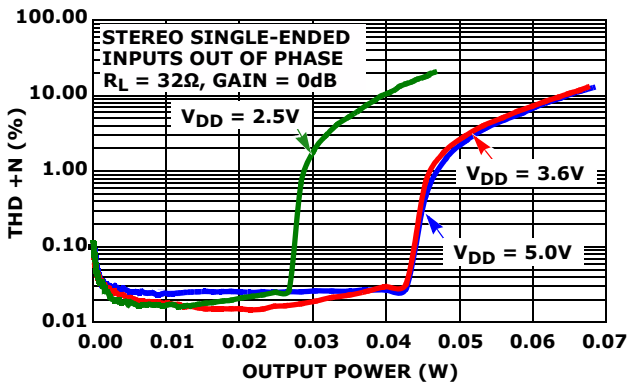

FIGURE 11. TOTAL HARMONIC DISTORTION + NOISE vs OUTPUT POWER

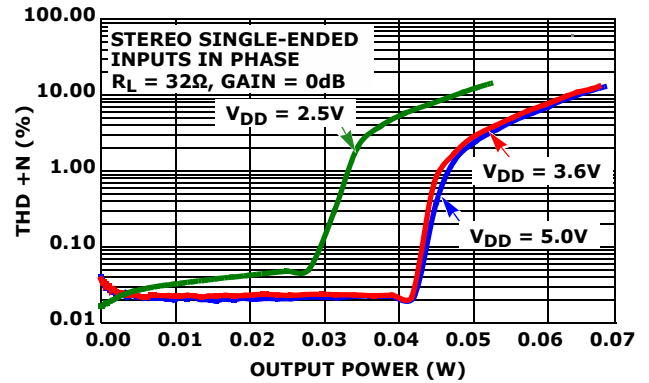

FIGURE 12. TOTAL HARMONIC DISTORTION + NOISE (HP) vs POWER

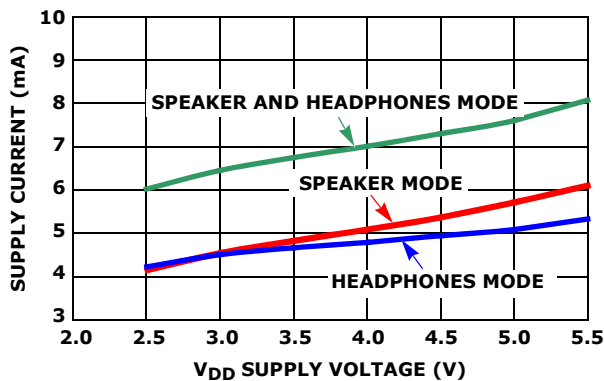

FIGURE 13. SUPPLY CURRENT vs SUPPLY VOLTAGE

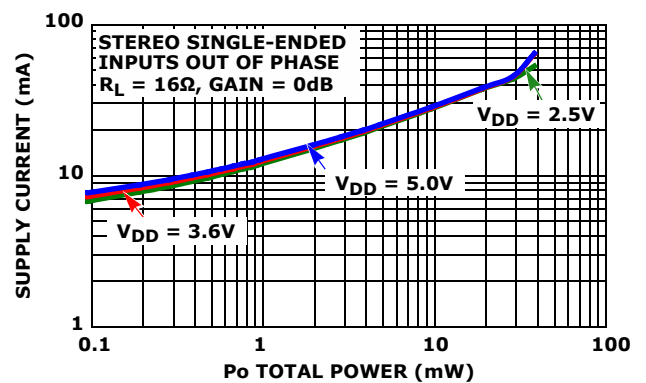

FIGURE 14. SUPPLY CURRENT (HEADPHONES) vs TOTAL OUTPUT POWER

Typical Performance Characteristics (Continued)

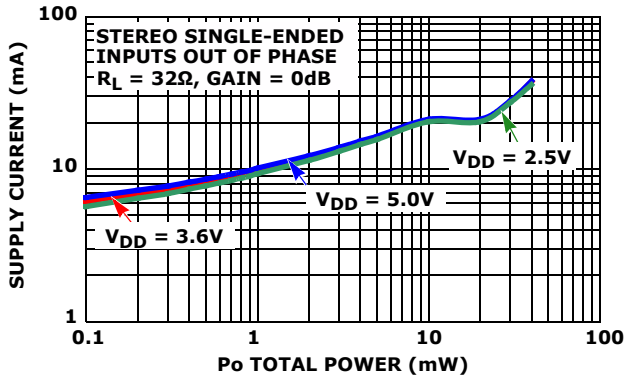

FIGURE 15. SUPPLY CURRENT (HEADPHONES) vs TOTAL OUTPUT POWER

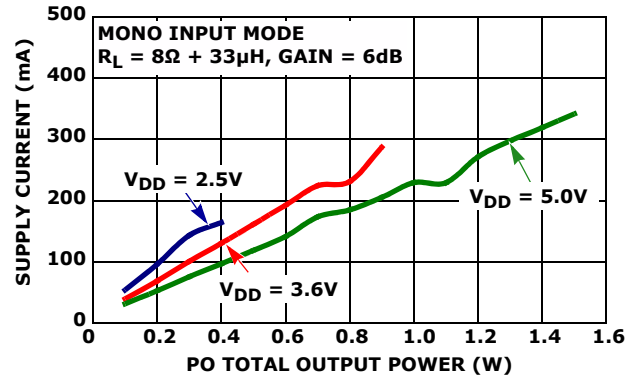

FIGURE 16. TOTAL POWER DISSIPATION (SPEAKER MODE) vs TOTAL OUTPUT POWER

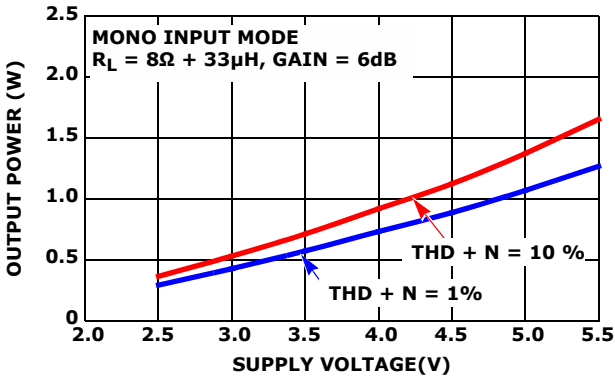

FIGURE 17. OUTPUT POWER (SPEAKER) vs SUPPLY VOLTAGE

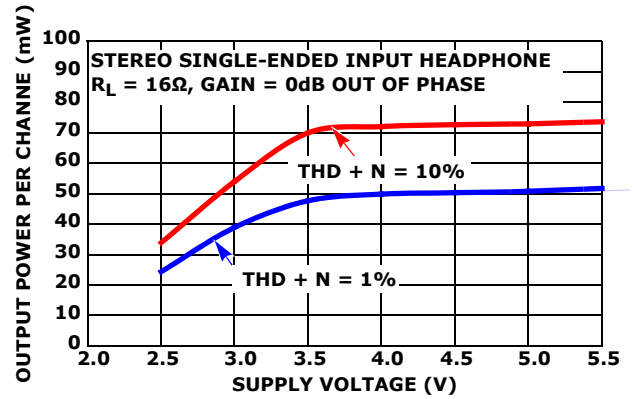

FIGURE 18. OUTPUT POWER PER CHANNEL (HEADPHONE) vs SUPPLY VOLTAGE

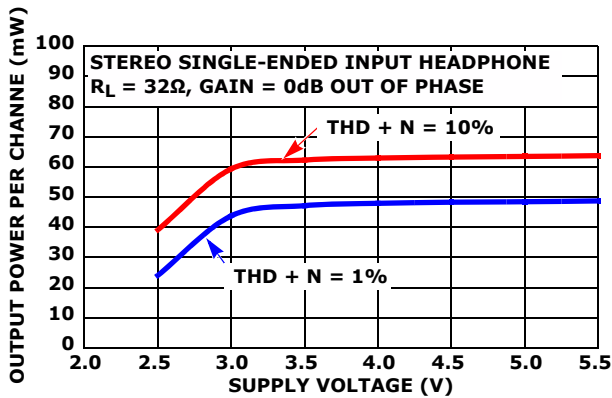

FIGURE 19. OUTPUT POWER PER CHANNEL (HEADPHONE) vs SUPPLY VOLTAGE

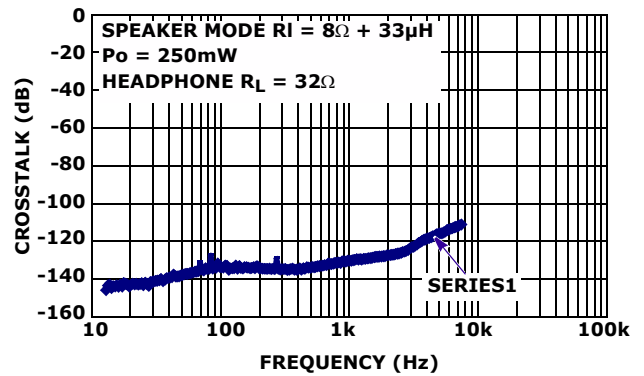

FIGURE 20. SPEAKER TO HEADPHONE CROSSTALK vs FREQUENCY

Typical Performance Characteristics (Continued)

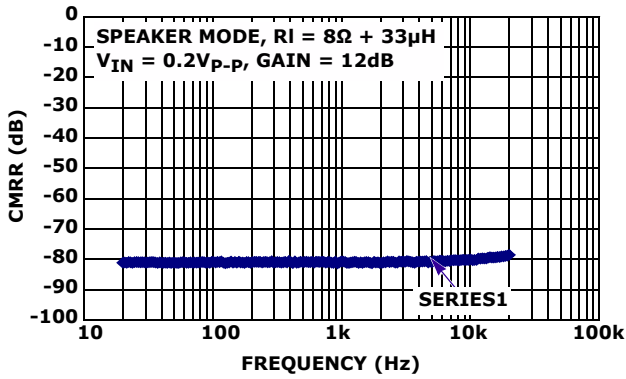

FIGURE 21. COMMON-MODE REJECTION RATIO vs FREQUENCY

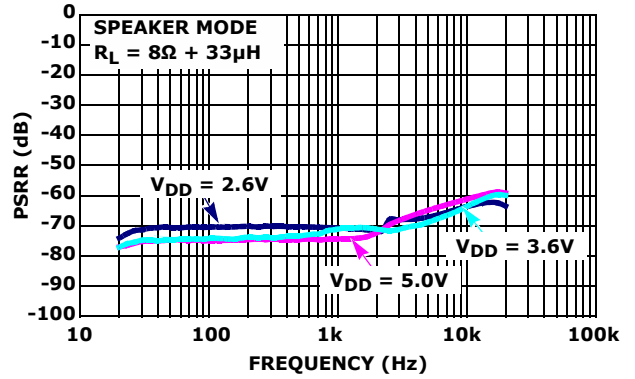

FIGURE 22. POWER SUPPLY REJECTION RATIO (SPEAKER) vs FREQUENCY

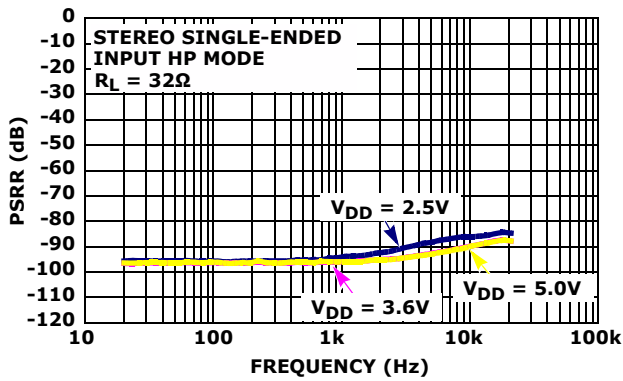

FIGURE 23. POWER SUPPLY REJECTION RATIO (HEADPHONES) vs FREQUENCY

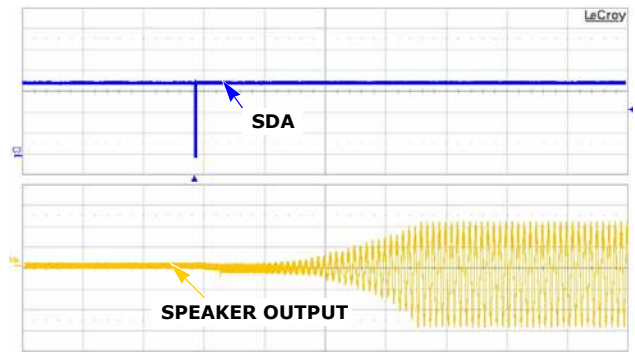

FIGURE 24. SPEAKER OUTPUT - START-UP

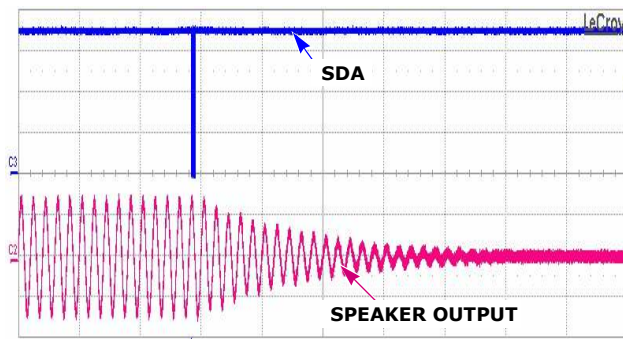

FIGURE 25. SPEAKER OUTPUT - SHUTDOWN

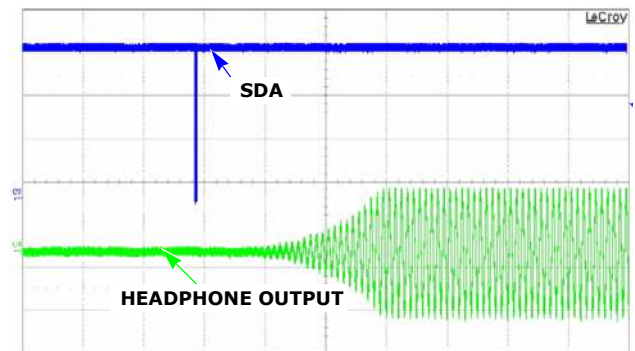

FIGURE 26. HEADPHONE OUTPUT - START-UP

## Typical Performance Characteristics (Continued)

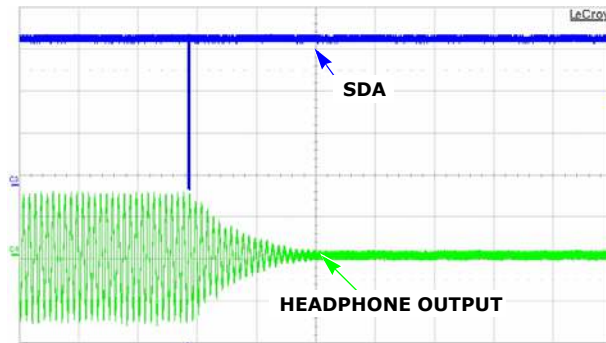

FIGURE 27. HEADPHONE OUTPUT - SHUTDOWN

### Theory of Operation

The ISL99203 supports an I<sup>2</sup>C bidirectional bus oriented protocol. The protocol defines any device that sends data onto the bus as a transmitter and the receiving device as the receiver. The device controlling the transfer is a master and the device being controlled is the slave. The master always initiates data transfers and provides the clock for both transmit and receive operations. Therefore, the ISL99203 operates as a slave device in all applications.

All communication over the I<sup>2</sup>C interface is conducted by sending the MSB of each byte of data first.

### Protocol Conventions

Data states on the SDA line must change only during SCL LOW periods. SDA state changes during SCL HIGH are reserved for indicating START and STOP conditions (see Figure 28). On power-up of the ISL99203, the SDA pin is in the input mode.

All I<sup>2</sup>C interface operations must begin with a START condition, which is a HIGH to LOW transition of SDA while SCL is HIGH. The ISL99203 continuously monitors the SDA and SCL lines for the START condition and does not respond to any command until this condition is met (see Figure 29). A START condition is ignored during the power-up of the device.

All I<sup>2</sup>C interface operations must be terminated by a STOP condition, which is a LOW to HIGH transition of SDA while SCL is HIGH (see Figure 28). A STOP condition at the end of a read operation, or at the end of a write operation places the device in its standby mode.

An ACK, Acknowledge, is a software convention used to indicate a successful data transfer. The transmitting device, either master or slave, releases the SDA bus after transmitting eight bits. During the ninth clock cycle, the receiver pulls the SDA line LOW to acknowledge the reception of the eight bits of data (see Figure 29).

The ISL99203 responds with an ACK after recognition of a START condition followed by a valid Identification Byte, and once again after successful receipt of an Address Byte. The ISL99203 also responds with an ACK after receiving a Data Byte of a write operation. The master must respond with an ACK after receiving a Data Byte of a read operation.

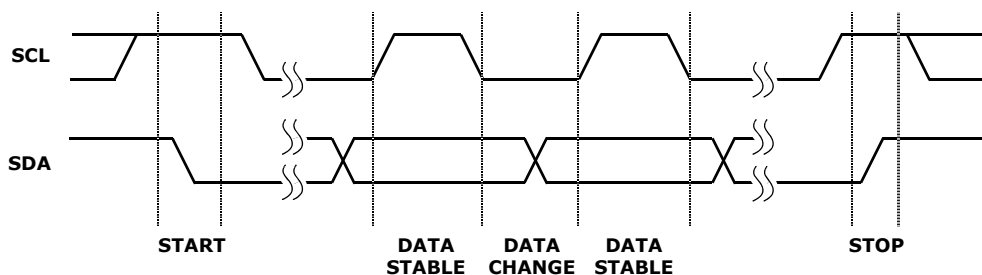

FIGURE 28. VALID DATA CHANGES, START, AND STOP CONDITIONS

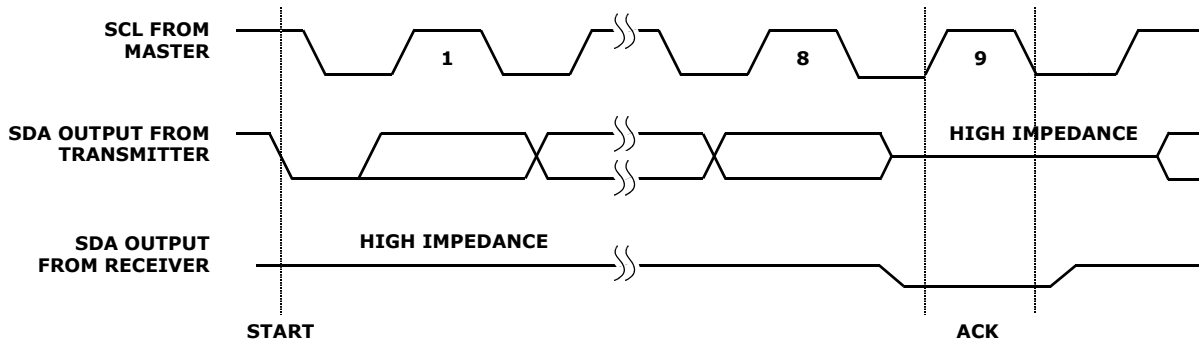

FIGURE 29. ACKNOWLEDGE RESPONSE FROM RECEIVER

## Revision History

The revision history provided is for informational purposes only and is believed to be accurate, but not warranted. Please go to web to make sure you have the latest Rev.

DATE	REVISION	CHANGE
6/21/10	FN7547.1	Added key performance graphics to page 1. Moved Pin Configurations, Pin Descriptions and ordering information to follow standards.
12/17/09	FN7547.0	Initial release.

## Products

Intersil Corporation is a leader in the design and manufacture of high-performance analog semiconductors. The Company's products address some of the industry's fastest growing markets, such as, flat panel displays, cell phones, handheld products, and notebooks. Intersil's product families address power management and analog signal processing functions. Go to [www.intersil.com/products](http://www.intersil.com/products) for a complete list of Intersil product families.

\* For a complete listing of Applications, Related Documentation and Related Parts, please see the respective device information page on intersil.com: [ISL99203](http://www.intersil.com/ISL99203)

To report errors or suggestions for this datasheet, please go to [www.intersil.com/askourstaff](http://www.intersil.com/askourstaff)

FITs are available from our website at <http://rel.intersil.com/reports/search.php>

For additional products, see [www.intersil.com/product\\_tree](http://www.intersil.com/product_tree)

Intersil products are manufactured, assembled and tested utilizing ISO9000 quality systems as noted in the quality certifications found at [www.intersil.com/design/quality](http://www.intersil.com/design/quality)

*Intersil products are sold by description only. Intersil Corporation reserves the right to make changes in circuit design, software and/or specifications at any time without notice. Accordingly, the reader is cautioned to verify that data sheets are current before placing orders. Information furnished by Intersil is believed to be accurate and reliable. However, no responsibility is assumed by Intersil or its subsidiaries for its use; nor for any infringements of patents or other rights of third parties which may result from its use. No license is granted by implication or otherwise under any patent or patent rights of Intersil or its subsidiaries.*

For information regarding Intersil Corporation and its products, see [www.intersil.com](http://www.intersil.com)

**Package Outline Drawing**  
**W4x5.20**

4x5 Array 20 Ball Wafer Level Chip Scale Package (WLCSP)  
Rev 1 8/09

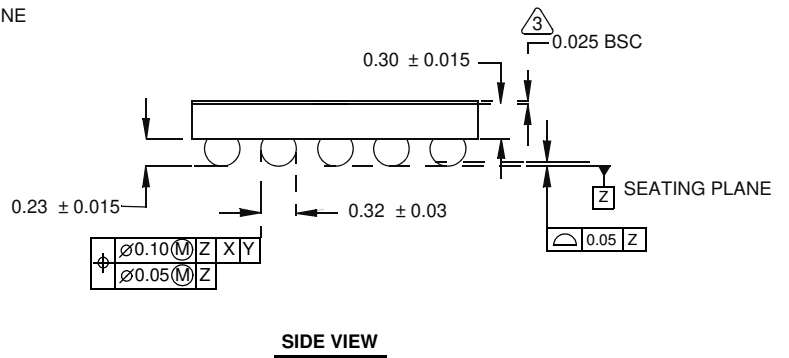
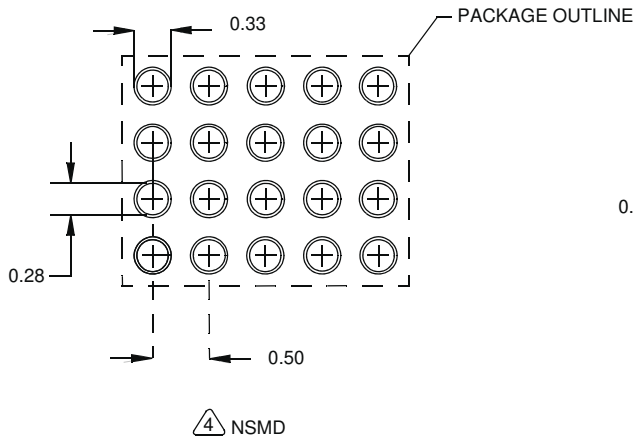
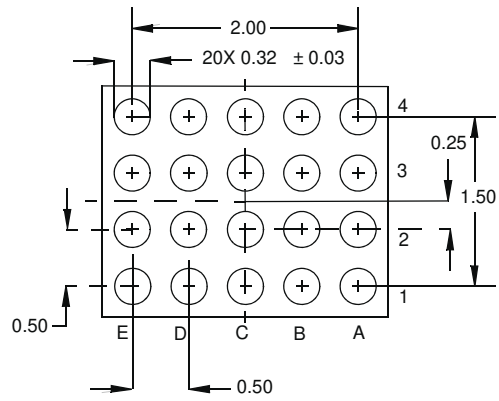
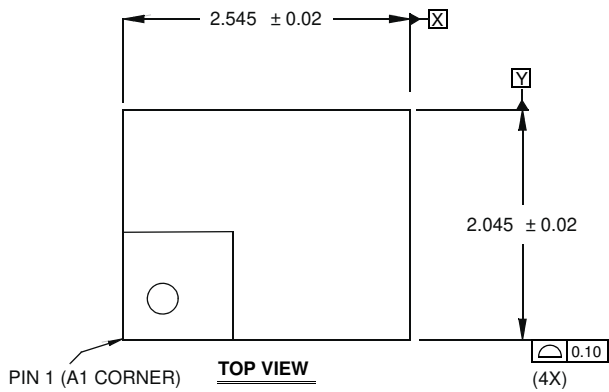

NOTES:

1. Dimensions are in millimeters.
2. Dimensioning and tolerancing conform to AMSE Y14.5m-1994, and JESD 95-1 SPP-10.
3. Back side coat 0.25mm thick applied to CSP package top.
4. NSMD refers to non-solder mask defined pad design per Intersil tech brief [www.intersil.com/data/tb/TB451.pdf](http://www.intersil.com/data/tb/TB451.pdf)