

Transfer or duplication of this document as well as the utilisation or communication of its content are not permitted unless express consent is granted. Violations give rise to claims for damages. All rights reserved in case of patent, utility model or design patent registrations.

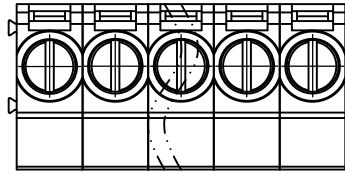

N=Number of contacts

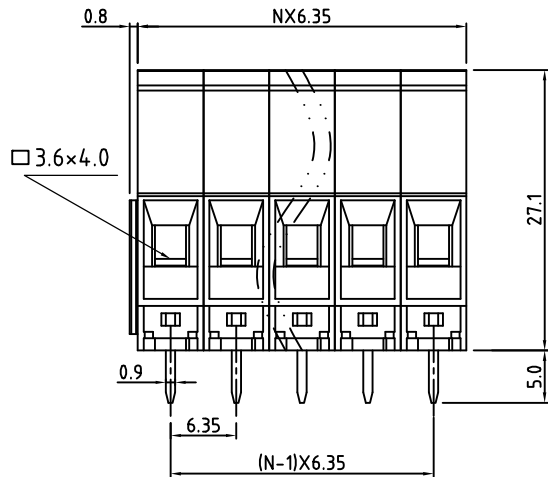

P.C.B. LAYOUT

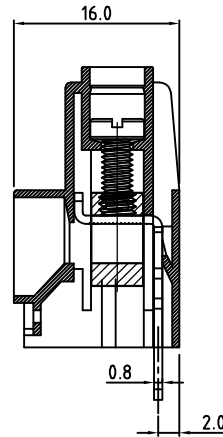
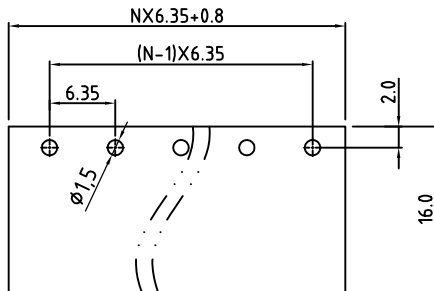

Technical Data:

Electrical

- Pitch: 6.35MM
- Voltage rating: 300V
- Current rating: 30 Amps
- Contact resistance: 20mΩ(max)
- Withstanding Voltage: 2500VAC(1min) Test time=60sec/1pcs
- Wire range: 6-20AWG
- Wire strip length: 8-9MM

Mechanical:

- Torque: 8.0kgf.cm/M3
- Operating temperature: -40°C to +105°C
- Soldering temperature: Temperature= 250°C±10°C / 5 seconds max
- Safety approval (pending):
- RoHS Compliance

Part No: **OSTKPXX0152**

| | |
|--|---|
| <p>No. of Poles</p> <p>02 2 Poles</p> <p>03 3 Poles</p> <p>... ..</p> <p>24 24 Poles</p> | <p>COLOR</p> <p>0: Black</p> <p>2: Red</p> <p>3: Orange</p> <p>4: Yellow</p> <p>5: Green (Standard)</p> <p>6: Blue</p> <p>8: Grey</p> |
|--|---|

Nonstandard colors
Mins could apply

| 4 | Screw | Steel / M3.0 | Cr3+ plated | 1xN |
|------|--------------|--------------|--|---------------|
| 3 | Contact | Copper Alloy | Ni plated | 1xN |
| 2 | Terminal | Copper Alloy | Tin plated | 1xN |
| 1 | Body | PA66 UL94V-0 | | 1 |
| ITEM | NAME OF PART | MATERIAL | NOTES | Q"TY |
| DWG. | DATE | UNITS: | MM | SHEET: 1 OF 1 |
| CHK. | DATE | SCALE: | NONE 2:1 (:) | REV.: A |
| APP. | DATE | TITLE: | OSTKP SERIES 6.35MM FRONT SINGLE ROW (WITHOUT COVER) | |
| | | PART NO. | OSTKPXX0152 | |
| | | DWG NO. | OSTKPXX0152.DWG | |

| REV | SIGN | DESCRIPTION | CHK. | DATE |
|-----|------|-------------|------|------|
| | | | | |



ON-SHORE TECHNOLOGY, INC.

| | |
|------|-------|
| X. | ±0.50 |
| X.X | ±0.30 |
| X.XX | ±0.10 |
| X* | ±1° |