

THIS DRAWING IS UNPUBLISHED. RELEASED FOR PUBLICATION 20
 © COPYRIGHT 20 BY - ALL RIGHTS RESERVED.

LOC	DIST	REVISIONS					
GP	00	P	LTR	DESCRIPTION	DATE	DWN	APVD
		A		RELEASED ECO-14-003843	31MAR2014	LAW	SB
		B		REVISED PER ECO-14-011711	01AUG2014	CJV	SLB

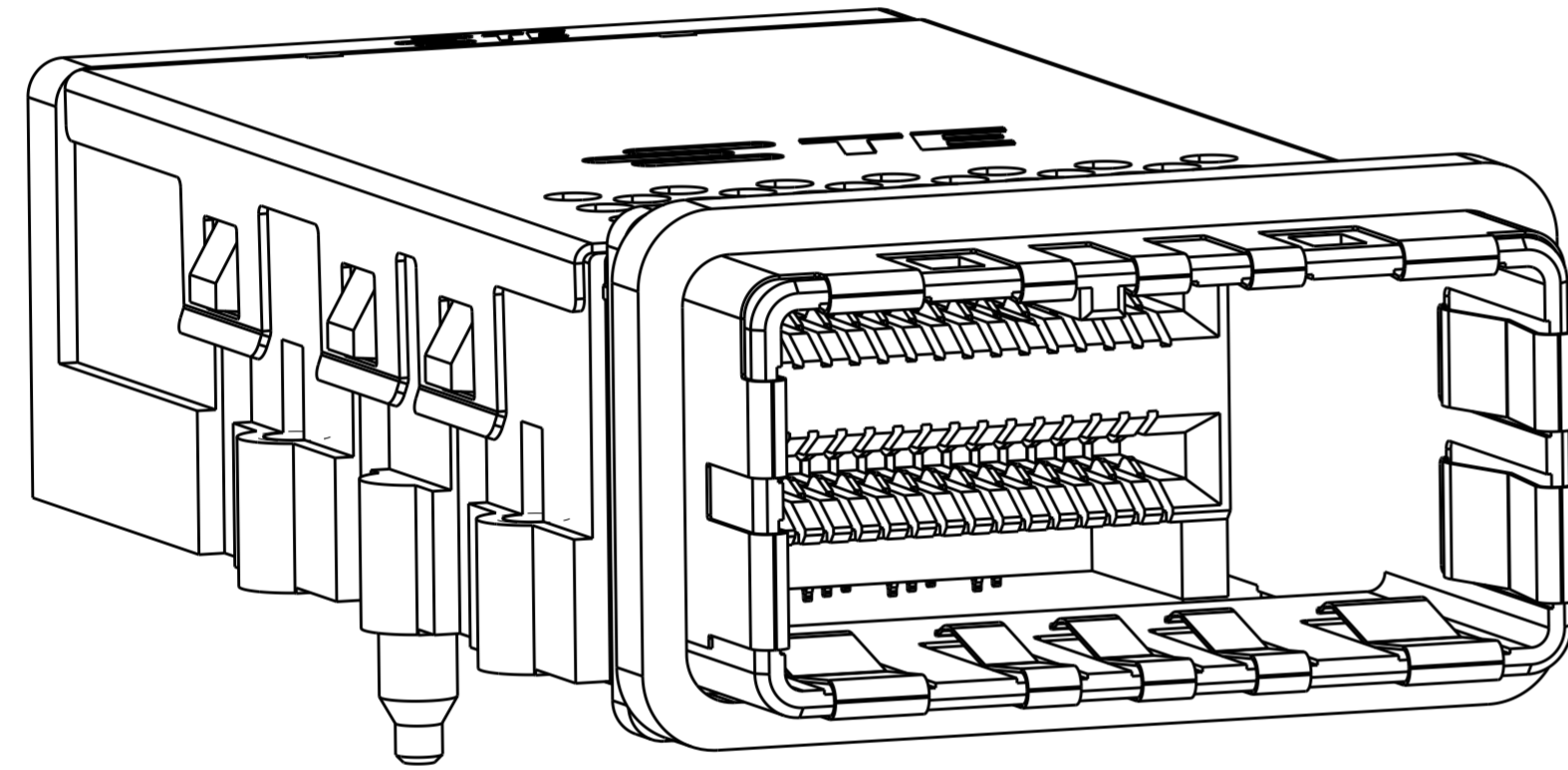

2149152-1
SCALE 5:1

- 1 MATERIALS:
 HOUSING - ZINC ALLOY
 COVER, HOUSING - STAINLESS STEEL.
 EMI GASKET - CONDUCTIVE URETHANE FOAM
 RECEPTACLE HOUSING - LCP, BLACK, UL 94V-0 RATED
 CHICKLET - LCP, BLACK, UL 94V-0 RATED
 CONTACT - PHOSPHOR BRONZE
 EMI SPRING - COPPER ALLOY
- 2 FINISH:
 CONTACT - CONFORMS TO THE REQUIREMENTS OF TE PRODUCT SPECIFICATION 108-2426, BASED ON EIA/ECA-364-1000.01A, (CONTROLLED ENVIRONMENT APPLICATIONS) ON MATING INTERFACE, MATTE TIN PLATE OVER NICKEL UNDERPLATE ON COMPLIANT PIN
 HOUSING - NICKEL PLATE
- 3 NOTE DELETED
- 4 PCB THICKNESS = 1.57 MIN
- 5 FOR HOLE SIZE AND FINISHES, SEE APPLICATION SPEC 114-13283
- 6 THE ENTIRE AREA OF THE CONNECTOR FOOTPRINT, INDICATED BY CROSSHATCHING, TO BE CONSIDERED THE KEEPOUT AREA FOR COMPONENTS AND SIGNAL TRACES, TOP SIDE ONLY, TOP SIDE TRACES ALLOWED WITHIN CONNECTOR HOLE PATTERN, CROSSHATCHING TO BE CONDUCTIVE
- 7. MOUNTING HARDWARE REQUIRED:
 M2X0.4 (4) - MOUNTING SCREW LENGTH = BOARD THICKNESS + 4mm MAX

OBSOLETE	2149448-2	3	84 POSITION RECEPTACLE ASSEMBLY	2149152-2
	2149448-1	2	84 POSITION RECEPTACLE ASSEMBLY	2149152-1
	RECEPTACLE HOUSING SUB-ASSEMBLY	FINISH	DESCRIPTION	PART NUMBER

THIS DRAWING IS A CONTROLLED DOCUMENT.		DWN M.E. COWHER 09 JUN 2010	STE TE Connectivity	
		CHK M.D. MORRISON 10 JUN 2010		
		APVD M.D. MORRISON 10 JUN 2010	NAME RECEPTACLE ASSEMBLY 84 POSITION, CXP	
DIMENSIONS: mm		PRODUCT SPEC 108-2426	SIZE A2	CAGE CODE 00779
TOLERANCES UNLESS OTHERWISE SPECIFIED: 0 PLC ±0.15 1 PLC ±0.15 2 PLC ±0.15 3 PLC ±0.15 4 PLC ±0.15 ANGLES ±0.5 FINISH		APPLICATION SPEC 114-13283	DRAWING NO C-2149152	RESTRICTED TO -
MATERIAL 1	2	WEIGHT -	SCALE 1:1	SHEET 1 OF 5
Customer Drawing			REV B	

THIS DRAWING IS UNPUBLISHED. RELEASED FOR PUBLICATION 20
 © COPYRIGHT 20 BY - ALL RIGHTS RESERVED.

LOC	DIST	REVISIONS					
GP	00	P	LTR	DESCRIPTION	DATE	DWN	APVD
		-		SEE SHEET 1			

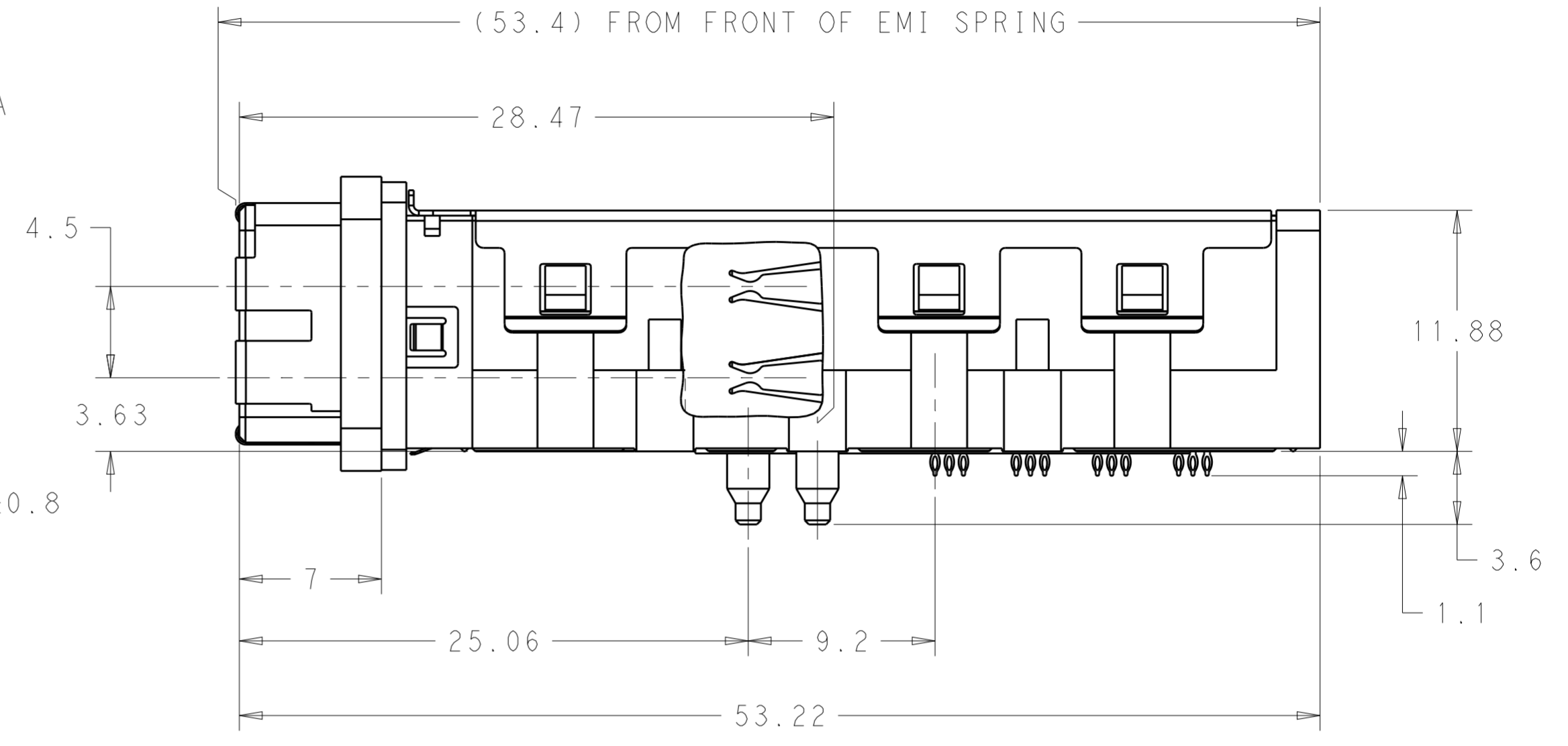
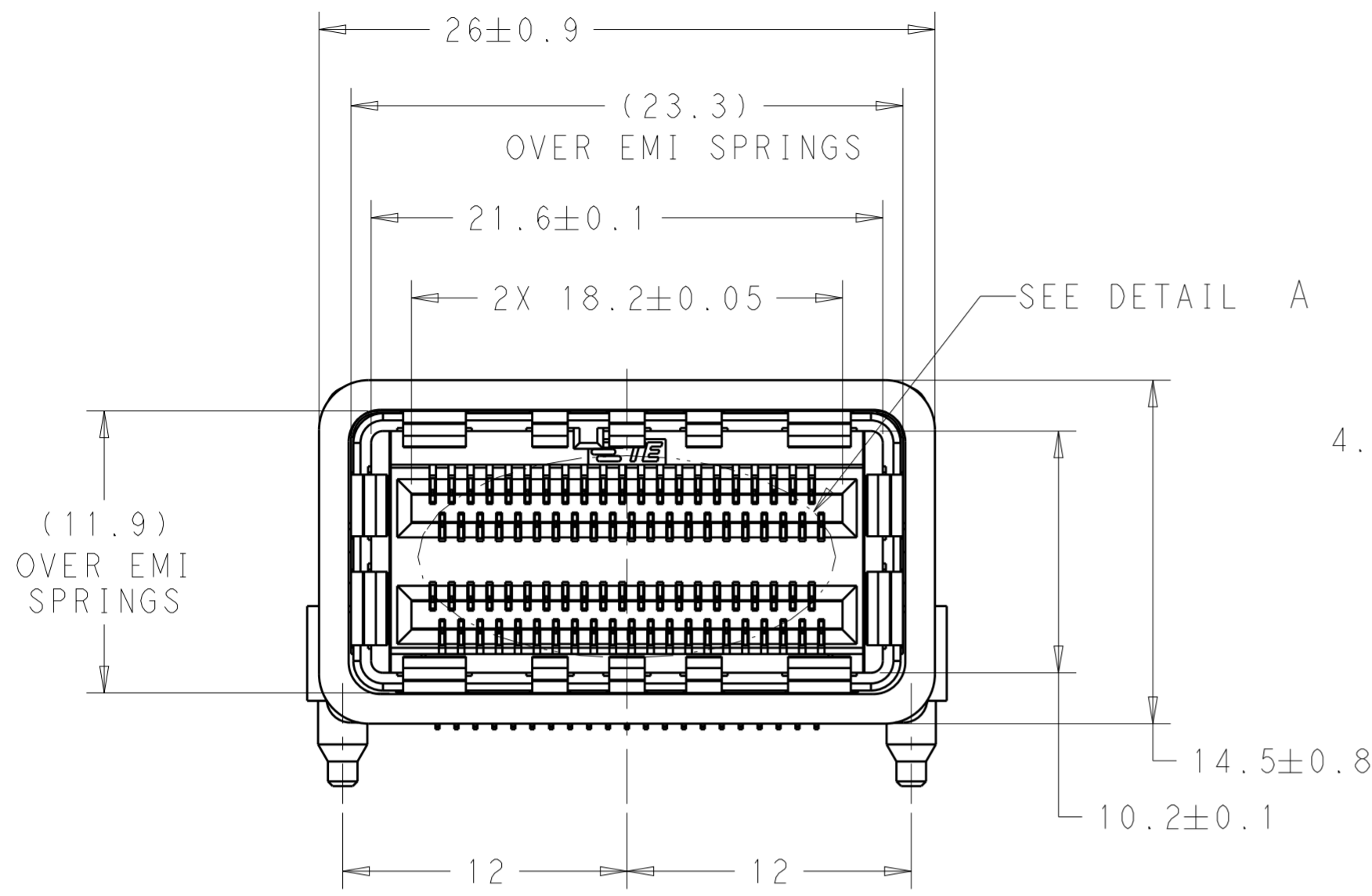

2149152-1
 SCALE 4:1

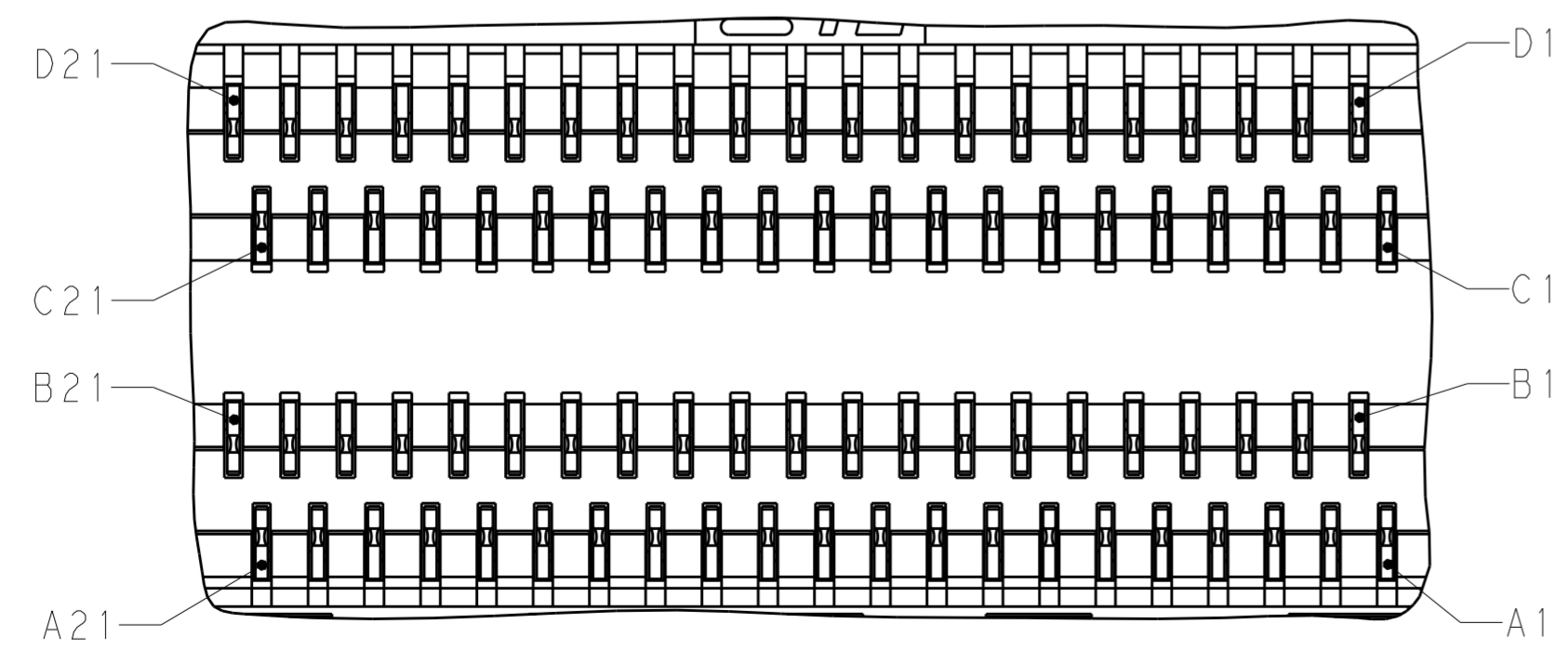

DETAIL A
 CONNECTOR PIN CALLOUT
 SCALE 10:1

THIS DRAWING IS A CONTROLLED DOCUMENT.		DWN M. E. COWHER 09 JUN 2010	TE Connectivity	
DIMENSIONS: mm		CHK M. D. MORRISON 10 JUN 2010		
TOLERANCES UNLESS OTHERWISE SPECIFIED:		APVD M. D. MORRISON 10 JUN 2010	NAME RECEPTACLE ASSEMBLY 84 POSITION, CXP	
0 PLC ±0.15 1 PLC ±0.15 2 PLC ±0.15 3 PLC ±0.15 4 PLC ±0.15 ANGLES ±0.5 FINISH		PRODUCT SPEC 108-2426	SIZE CAGE CODE DRAWING NO RESTRICTED TO	
MATERIAL		APPLICATION SPEC 114-13283	A200779 C-2149152	
		WEIGHT -	SCALE 4:1 SHEET 2 OF 5 REV B	
		Customer Drawing		

THIS DRAWING IS UNPUBLISHED. RELEASED FOR PUBLICATION 20
 © COPYRIGHT 20 BY - ALL RIGHTS RESERVED.

LOC	DIST	REVISIONS			
P	LTR	DESCRIPTION	DATE	DWN	APVD
GP	00	SEE SHEET 1	-	-	-

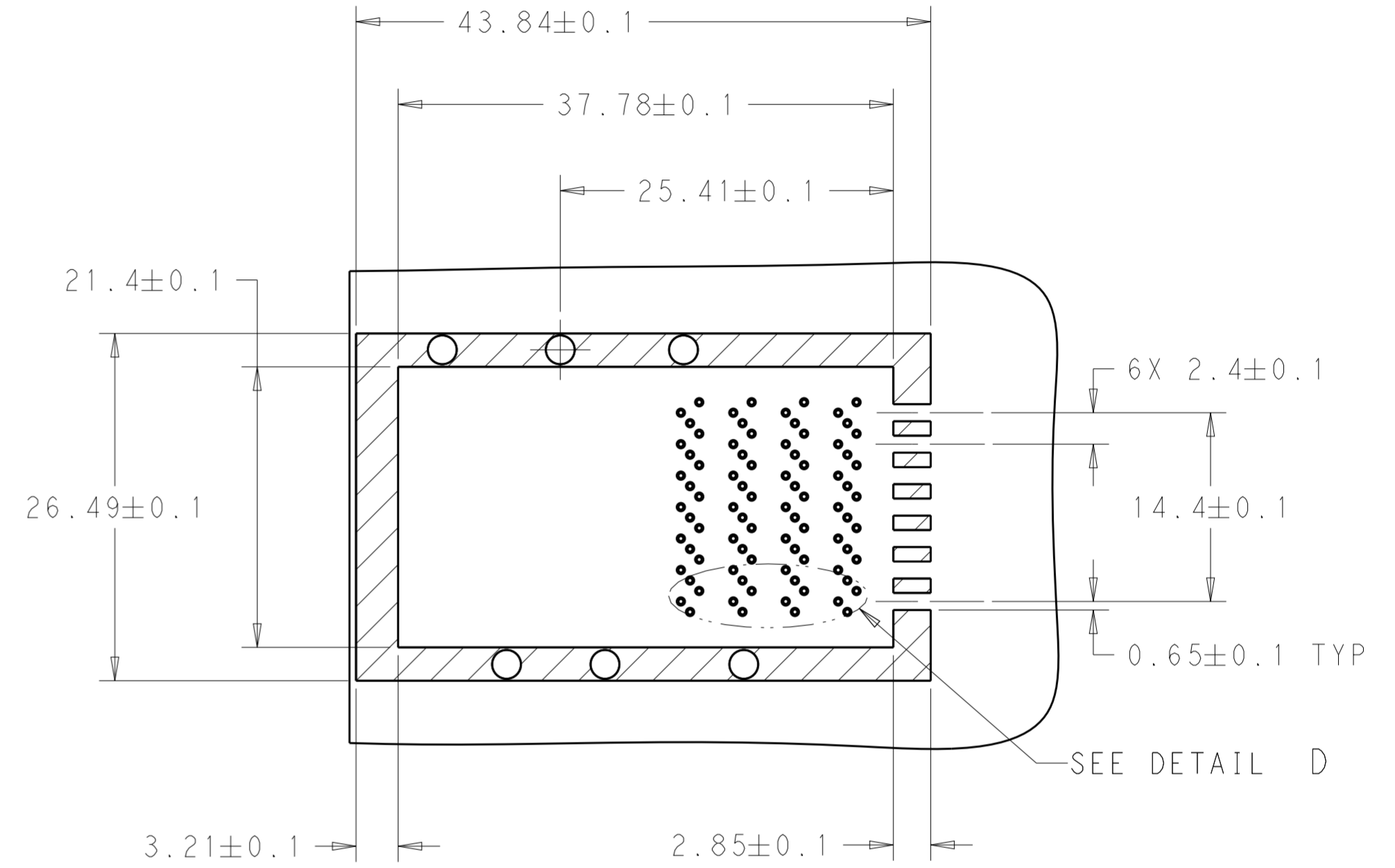
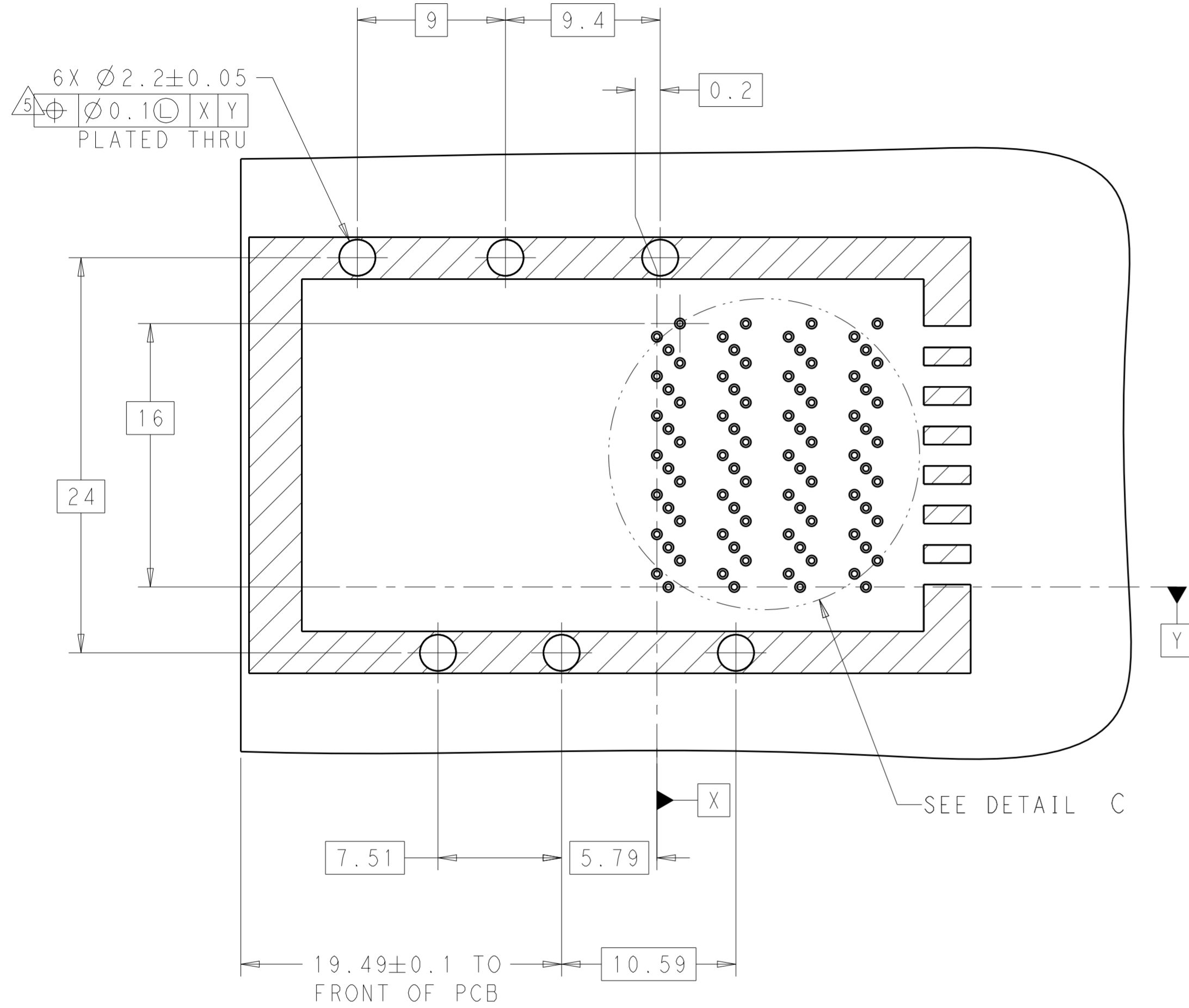

RECOMMENDED KEEPOUT AREA
 SCALE 5:2

RECOMMENDED PCB LAYOUT
 COMPONENT SIDE SHOWN
 SCALE 4:1

THIS DRAWING IS A CONTROLLED DOCUMENT.		DWN M. E. COWHER 09 JUN 2010	TE Connectivity	
DIMENSIONS: mm		CHK M. D. MORRISON 10 JUN 2010		
TOLERANCES UNLESS OTHERWISE SPECIFIED:		APVD M. D. MORRISON 10 JUN 2010	NAME RECEPTACLE ASSEMBLY 84 POSITION, CXP	
0 PLC ±0.15 1 PLC ±0.15 2 PLC ±0.15 3 PLC ±0.15 4 PLC ±0.15 ANGLES ±0.5 FINISH		PRODUCT SPEC 108-2426	RESTRICTED TO	
MATERIAL		APPLICATION SPEC 114-13283	SIZE A200779	DRAWING NO C-2149152
		WEIGHT -	SCALE 3:1	SHEET 3 OF 5
		Customer Drawing	REV B	

THIS DRAWING IS UNPUBLISHED. RELEASED FOR PUBLICATION 20
 © COPYRIGHT 20 BY - ALL RIGHTS RESERVED.

LOC	DIST	REVISIONS					
GP	00	P	LTR	DESCRIPTION	DATE	DWN	APVD
		-		SEE SHEET 1	-	-	-

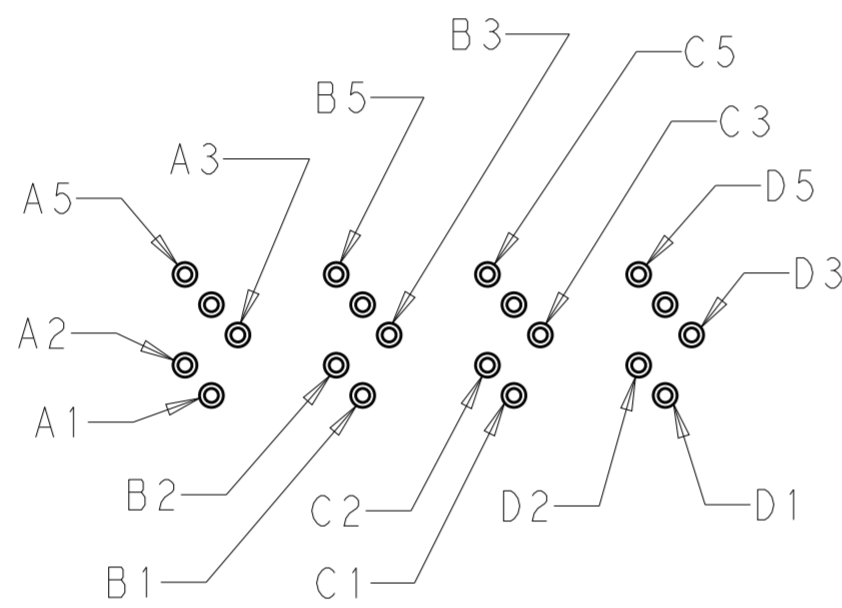

DETAIL D
 PIN CALLOUT (TYPICAL)
 SCALE 5:1

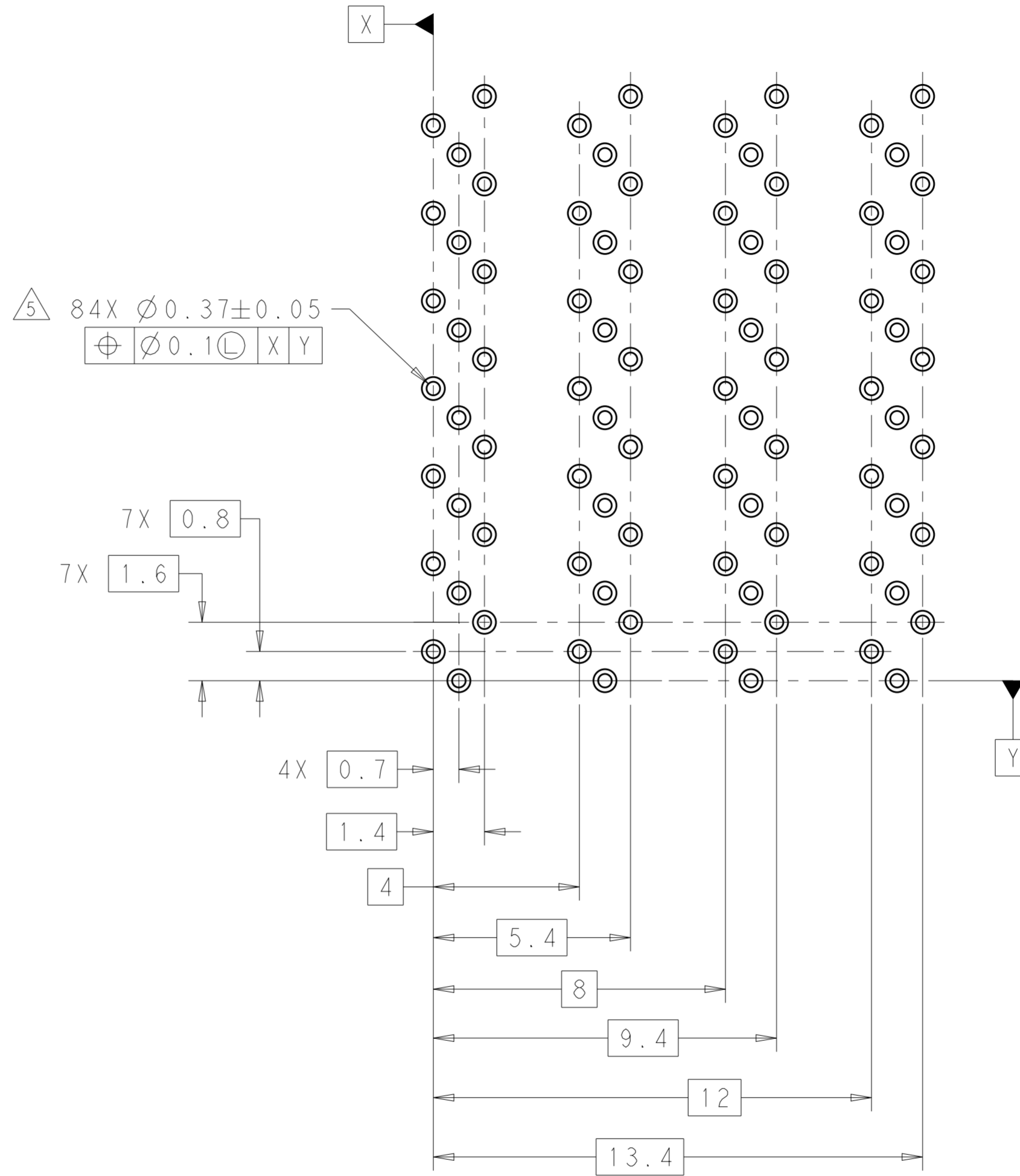

DETAIL C
 RECOMMENDED CONNECTOR LAYOUT
 SCALE 8:1

THIS DRAWING IS A CONTROLLED DOCUMENT.		DWN M. E. COWHER 09 JUN 2010	TE Connectivity	
DIMENSIONS: mm		CHK M. D. MORRISON 10 JUN 2010		
TOLERANCES UNLESS OTHERWISE SPECIFIED:		APVD M. D. MORRISON 10 JUN 2010	NAME RECEPTACLE ASSEMBLY 84 POSITION, CXP	
0 PLC ±0.15 1 PLC ±0.15 2 PLC ±0.15 3 PLC ±0.15 4 PLC ±0.15 ANGLES ±0.5 FINISH		PRODUCT SPEC 108-2426	RESTRICTED TO	
MATERIAL		APPLICATION SPEC 114-13283	SIZE A200779	DRAWING NO. C-2149152
		WEIGHT -	SCALE 4:1	SHEET 4 OF 5
		Customer Drawing	REV B	

THIS DRAWING IS UNPUBLISHED. RELEASED FOR PUBLICATION 20
 © COPYRIGHT 20 BY - ALL RIGHTS RESERVED.

LOC	DIST	REVISIONS					
GP	00	P	LTR	DESCRIPTION	DATE	DWN	APVD
		-		SEE SHEET 1	-	-	-

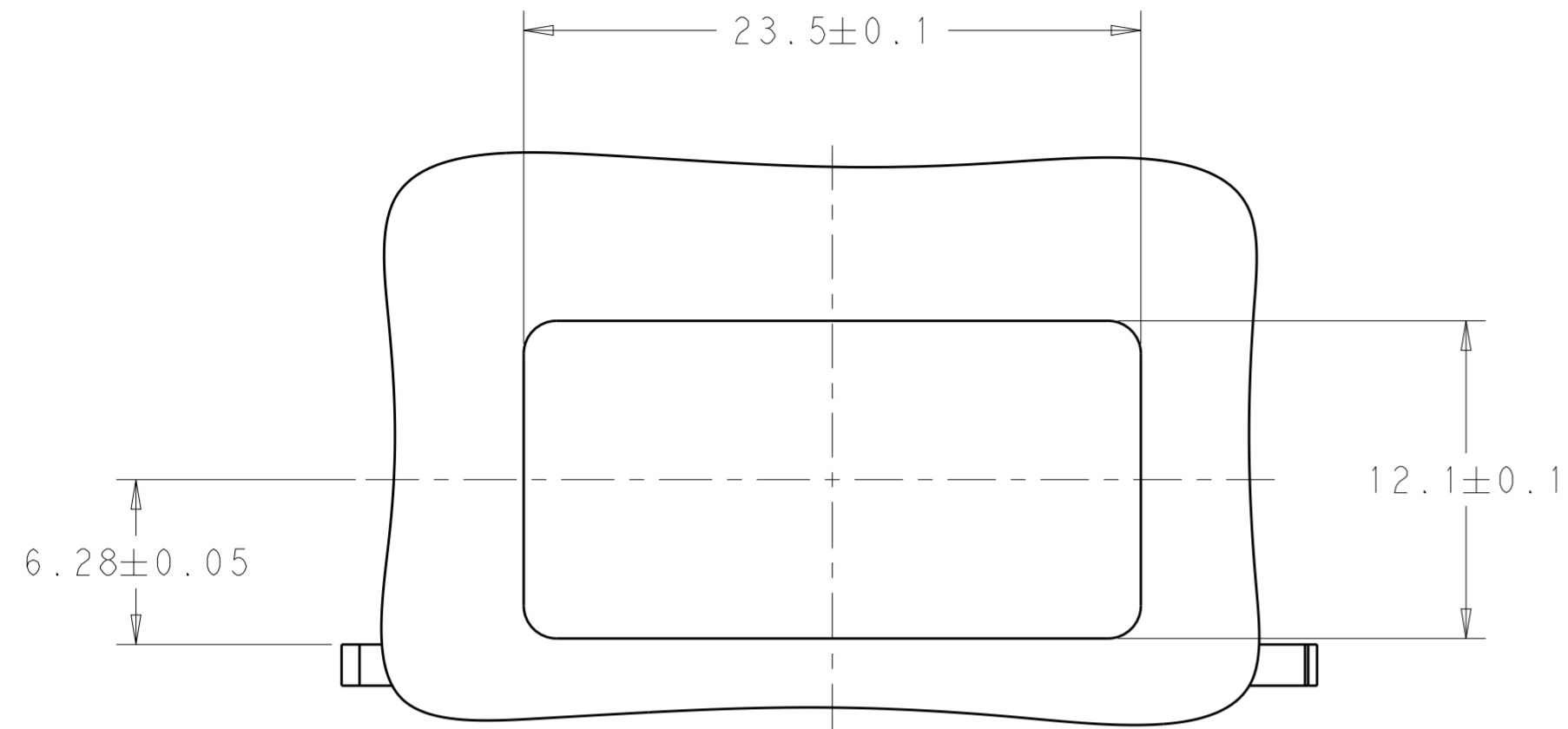

RECOMMENDED BRACKET CUT-OUT
SCALE 4:1

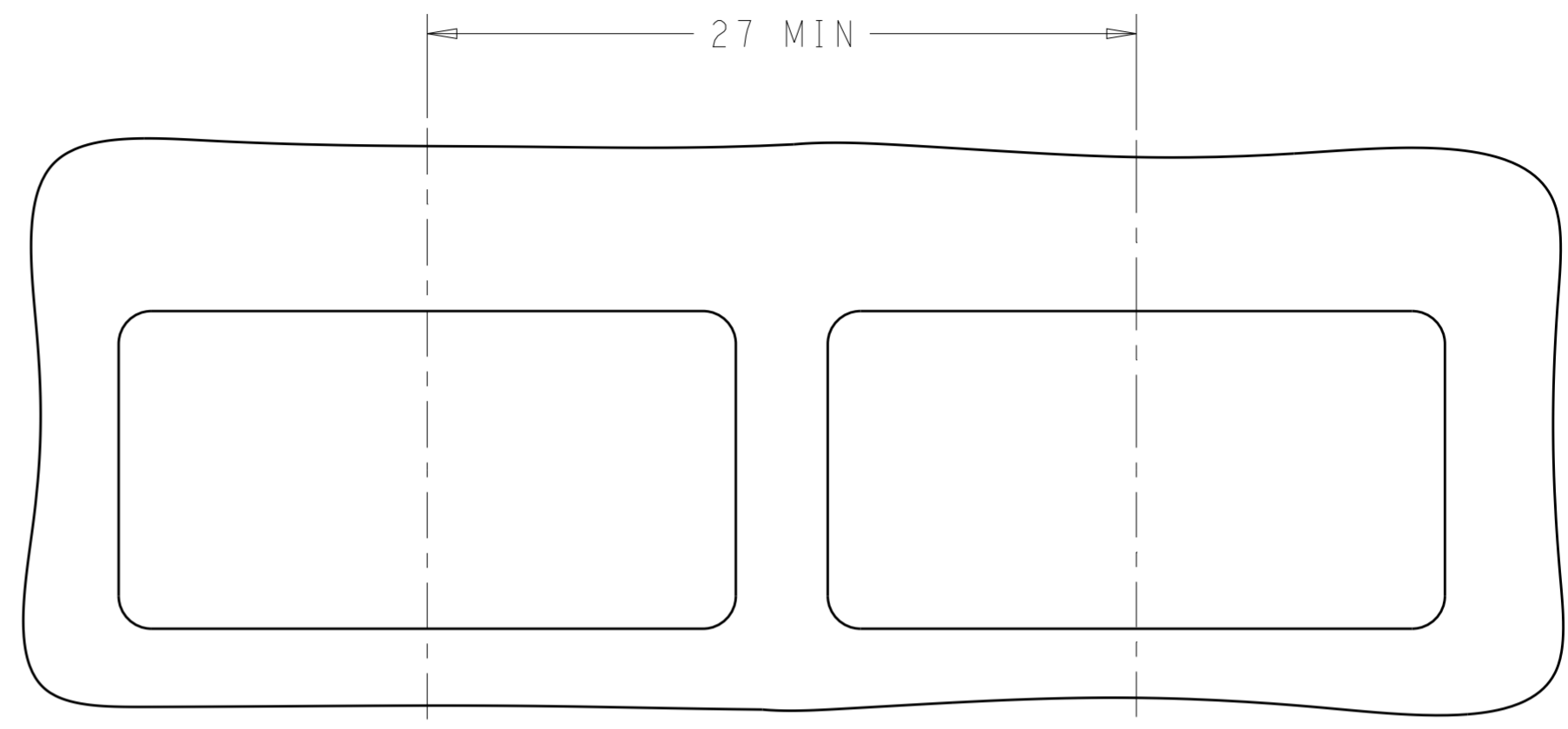

RECOMMENDED BRACKET CUT-OUT SPACING
SCALE 4:1

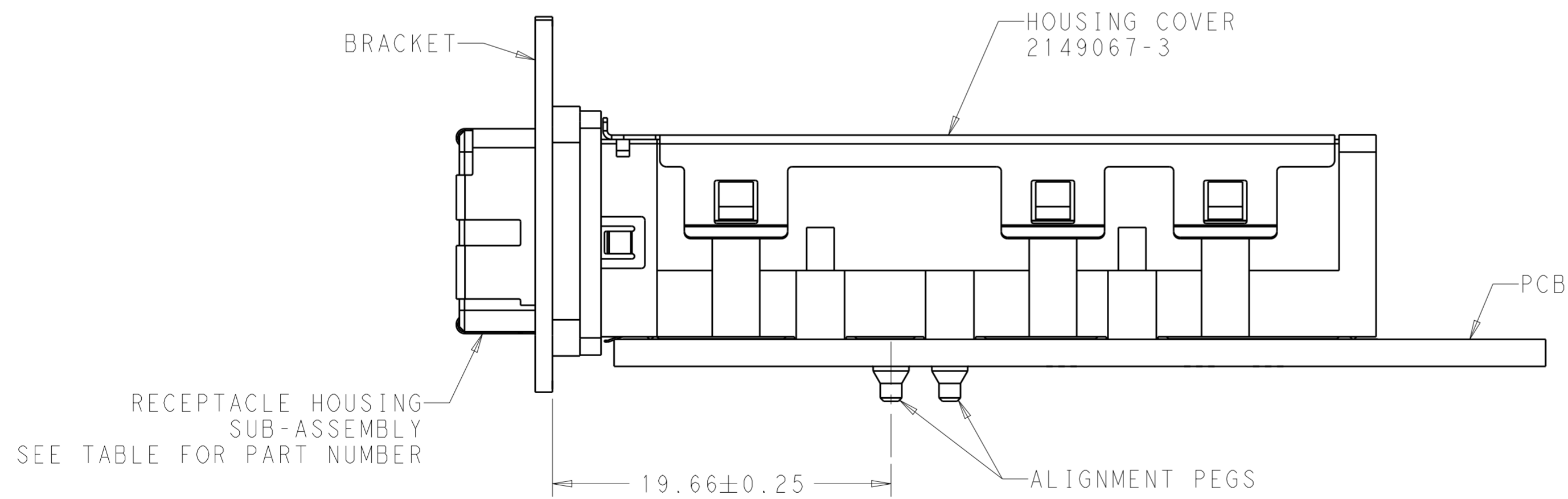

RECOMMENDED BRACKET LOCATION
SCALE 4:1

THIS DRAWING IS A CONTROLLED DOCUMENT.		DWN M. E. COWHER 09 JUN 2010	TE Connectivity	
DIMENSIONS: mm		CHK M. D. MORRISON 10 JUN 2010		
TOLERANCES UNLESS OTHERWISE SPECIFIED:		APVD M. D. MORRISON 10 JUN 2010	NAME RECEPTACLE ASSEMBLY 84 POSITION, CXP	
0 PLC ±0.15 1 PLC ±0.15 2 PLC ±0.15 3 PLC ±0.15 4 PLC ±0.15 ANGLES ±0.5 FINISH		PRODUCT SPEC 108-2426	RESTRICTED TO	
MATERIAL		APPLICATION SPEC 114-13283	SIZE A200779	DRAWING NO C-2149152
		WEIGHT -	SCALE 1:1 SHEET 5 OF 5 REV B	
		Customer Drawing		