

NUMBER GS-20-0355	TYPE <b>Application Specification</b>	<b>Amphenol FCI</b>	
TITLE BTFW series (1.0mm staggered pitch Board to Board connector)		PAGE 1 of 8	REVISION B
		AUTHORIZED BY S.Watanabe	DATE Sep./05/'18
CLASSIFICATION <b>UNRESTRICTED</b>			

### 1.0 Scope

This standard summarizes the important items for using the 1.0mm staggered pitch Board to Board connector " BTFW series". Before this connector is used, please be sure to look through these specifications.

### 2.0 Application product

Product name	Product No.
BTFW series connector	BTFW**P-***** BTFW**R-*****

### 3.0 Part numbers structure

<u>BTFW</u>	<u>20</u>	<u>R</u>	-	<u>3</u>	<u>R</u>	<u>ST</u>	<u>G</u>	<u>E4</u>	<u>LF</u>
1	2	3		4	5	6	7	8	9

1	Series name
2	Number of contact
3	Connector Type P : Plug R : Receptacle
4	Number of contact rows Two rows (Staggered)
5	Terminal type S : Straight R : Right angle
6	Terminal variation ST : SMT without boss SB : SMT with boss D : Dipping type
7	Plating Option G : Contact area Gold plating Terminal area: Tin plating A : Contact area Gold plating Terminal area : Tin plating Blank : Tin plating
8	Packaging E4 : Plastic reel (SMT Type) 7 : Tray (Only for Dipping Type Rece)
9	Lead free

NUMBER GS-20-0355	TYPE Application Specification	<b>Amphenol FCI</b>	
TITLE BTFW series (1.0mm staggered pitch Board to Board connector)		PAGE 2 of 8	REVISION B
		AUTHORIZED BY S.Watanabe	DATE Sep./05/'18
CLASSIFICATION <b>UNRESTRICTED</b>			

#### 4.0 Each part name

**Plug connector**

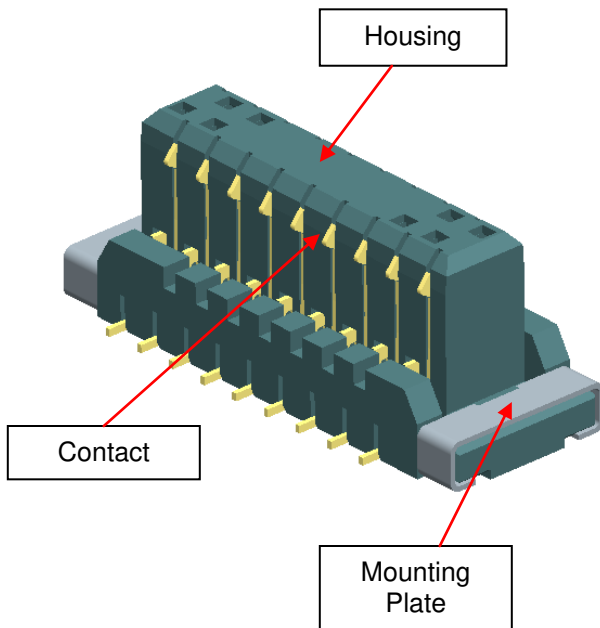

**Receptacle connector**

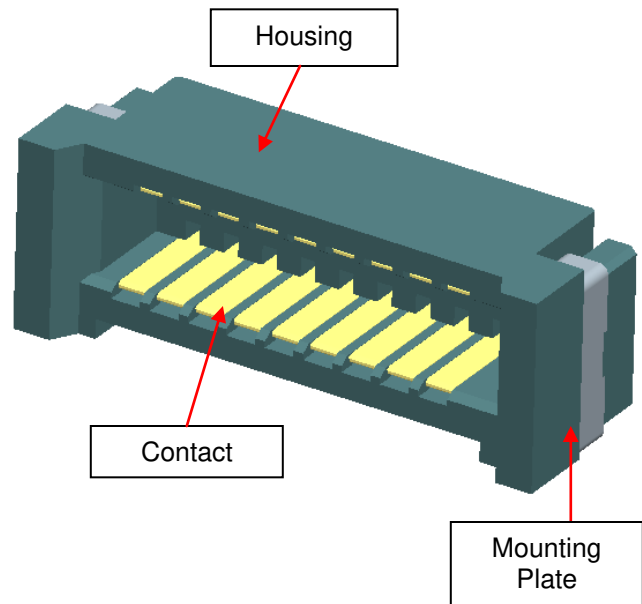

NUMBER GS-20-0355	TYPE <b>Application Specification</b>	<b>Amphenol FCI</b>	
TITLE BTFW series (1.0mm staggered pitch Board to Board connector)		PAGE 3 of 8	REVISION B
		AUTHORIZED BY S.Watanabe	DATE Sep./05/'18
		CLASSIFICATION <b>UNRESTRICTED</b>	

## 5.0 Mounting method

### 5.1 Recommended PCB layout Refer to drawings

### 5.2 Mounting method of the connector on the PCB

#### 5.2.1 SMT Type Connector

This connector has adopted the form of automatic mounting and the surface mount match. Therefore, please mount the connector to PCB with the automatic mounting machine. Then, please perform reflow soldering by the following our company recommendation conditions.

- 1) Recommended Stencil thickness : 0.15mm
- 2) Recommended Reflow condition : See below

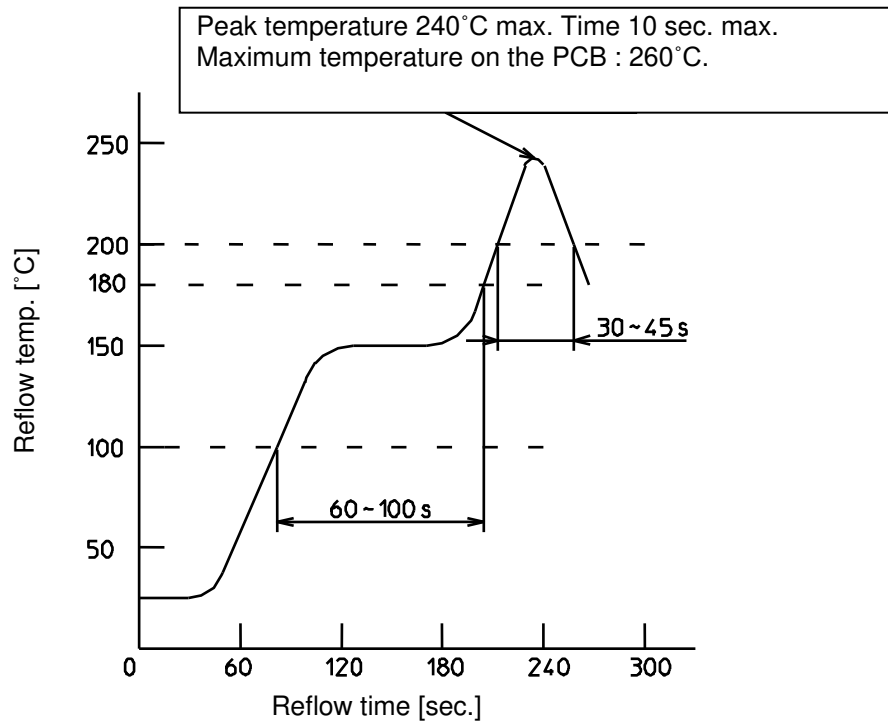

#### 5.2.2 DIP Type Connector

Dipping type proceeds flow soldering after inserting into the PCB

- 1) Solder Temp. : 250°C max
- 2) Soldering Time : 5sec. max.

NUMBER GS-20-0355	TYPE Application Specification	Amphenol FCI	
TITLE BTFW series (1.0mm staggered pitch Board to Board connector)		PAGE 4 of 8	REVISION B
		AUTHORIZED BY S.Watanabe	DATE Sep./05/'18
CLASSIFICATION UNRESTRICTED			

Note

- 1) Please take care hand soldering of rework to prevent penetrating flux on to the contacting portion.
- 2) Please take care hand soldering of rework, do not apply external force to the contact lead section at the soldering iron point.
- 3) Please do not solder when connector is mated condition.
- 4) Please do not touch the contact portion by hand.
- 5) Please control warpage of PCB. Soldering may become poor, if PCB warpage is large.
- 6) Please do not give the external force beyond 0.5N to a connector before mounting.  
Connector may be damaged.
- 7) Do not apply any forces affecting soldered joints when PC Board cut off multiple board and screw clamp of board etc.

6.0 Cautions for operation

6.1 Mating method

Please adjust the center line of connectors and mating straight.  
Mating angle is the following figure.

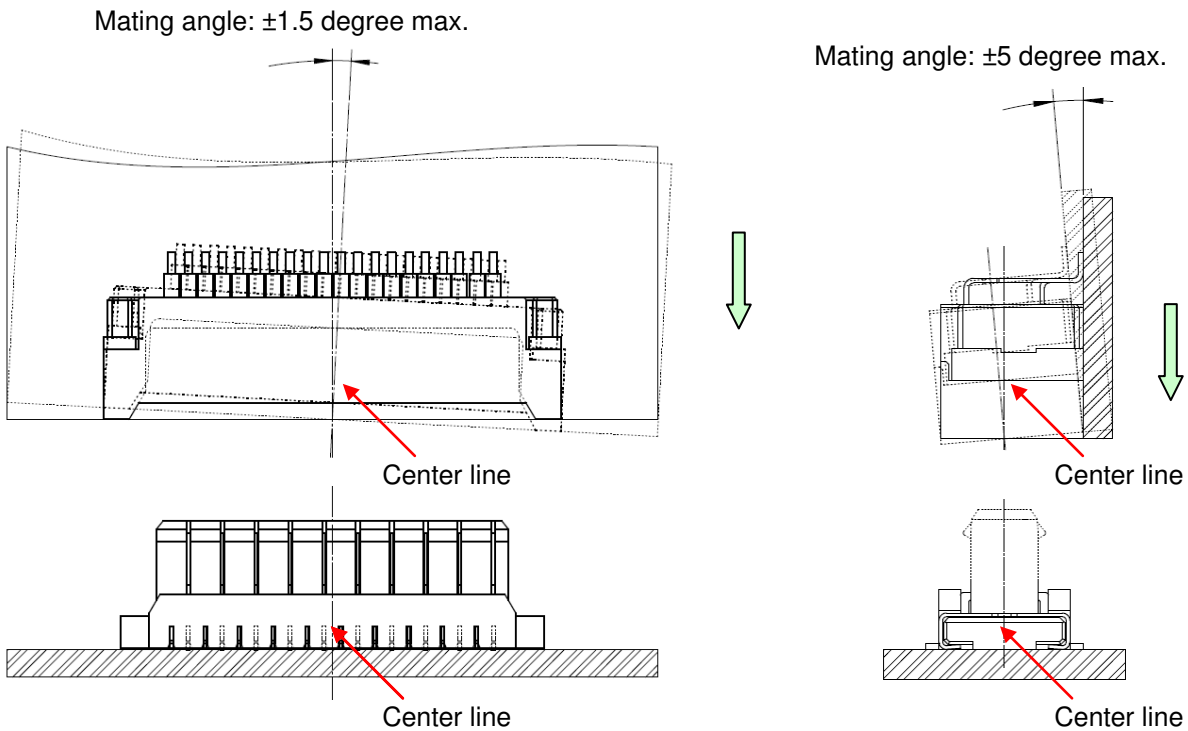

NUMBER GS-20-0355	TYPE Application Specification	Amphenol FCI	
TITLE BTFW series (1.0mm staggered pitch Board to Board connector)		PAGE 5 of 8	REVISION B
		AUTHORIZED BY S.Watanabe	DATE Sep./05/'18
CLASSIFICATION <b>UNRESTRICTED</b>			

6.2 Mating allowance

(1) X direction allowance :  $\pm 0.5\text{mm}$  max.

Mating allowance:  $+0.5\text{mm}$  max.

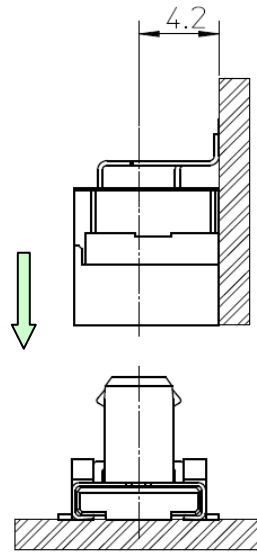
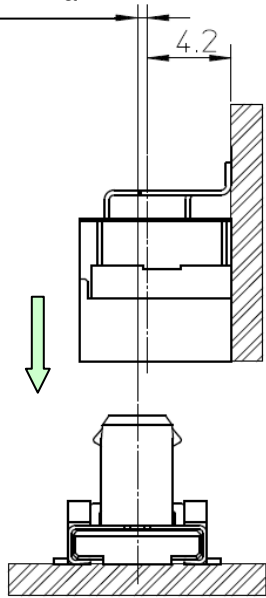

Center condition

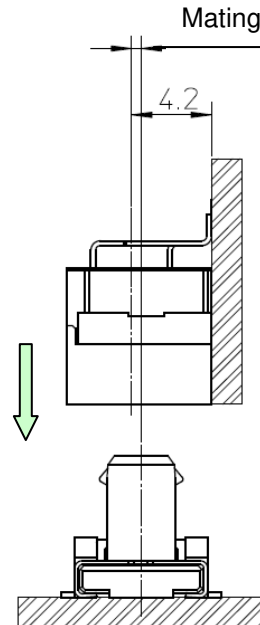

Mating allowance:  $-0.5\text{mm}$  max.

(2) Y direction allowance :  $\pm 0.8\text{mm}$  max.

Mating allowance:  $+0.8\text{mm}$  max.

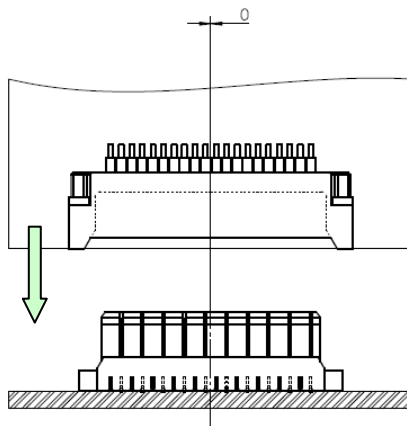
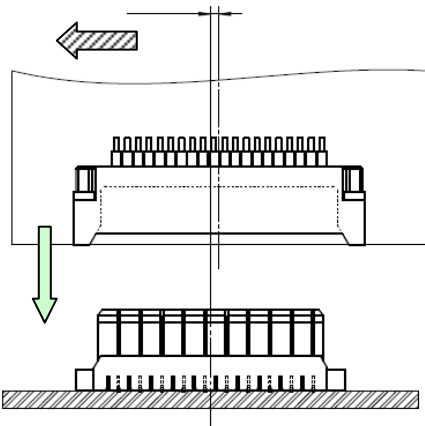

Center condition

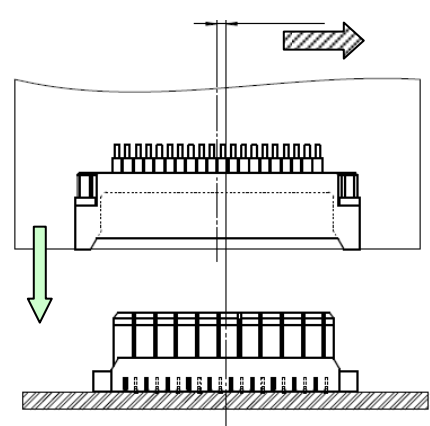

Mating allowance:  $-0.8\text{mm}$  max.

NUMBER GS-20-0355	TYPE Application Specification	Amphenol FCI	
TITLE BTFW series (1.0mm staggered pitch Board to Board connector)		PAGE 6 of 8	REVISION B
		AUTHORIZED BY S.Watanabe	DATE Sep./05/'18
CLASSIFICATION <b>UNRESTRICTED</b>			

6.3 Mating allowance after mating

(1) X direction allowance after mating :  $\pm 0.5\text{mm}$  max.

Mating allowance:  $+0.5\text{mm}$  max.

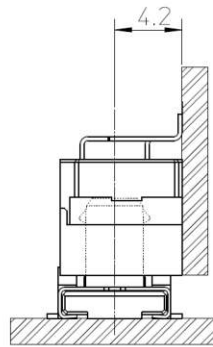
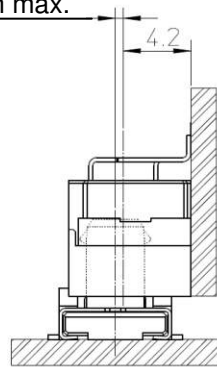

Center condition

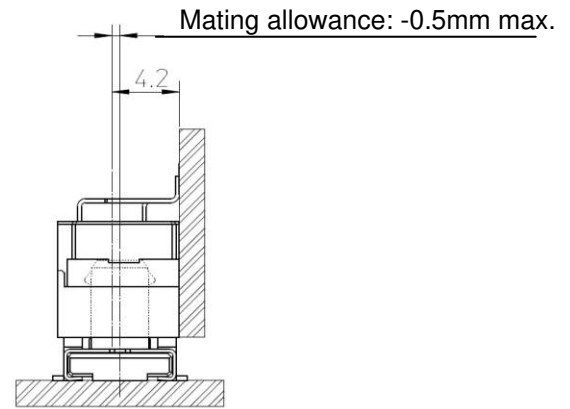

(2) Y direction allowance after mating :  $\pm 0.8\text{mm}$  max.

Mating allowance :  $+0.8\text{mm}$  max.

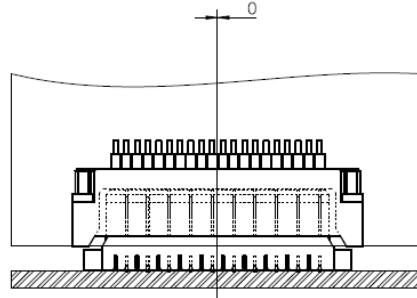
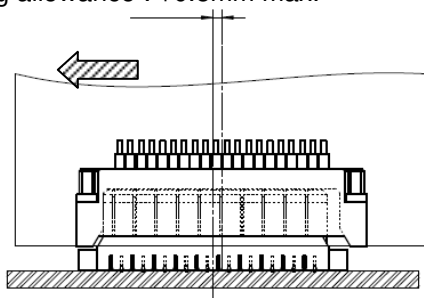

Center condition

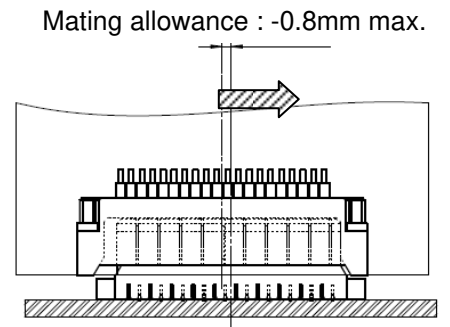

(3) Z direction allowance after mating :  $\pm 0.5\text{mm}$  max.

Mating allowance:  $+0.5\text{mm}$  max.

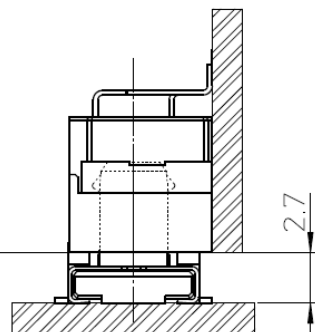
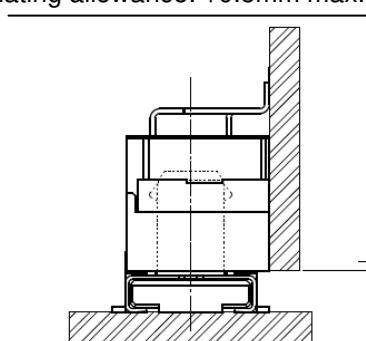

Center condition

Mating allowance:  $-0.5\text{mm}$  max.

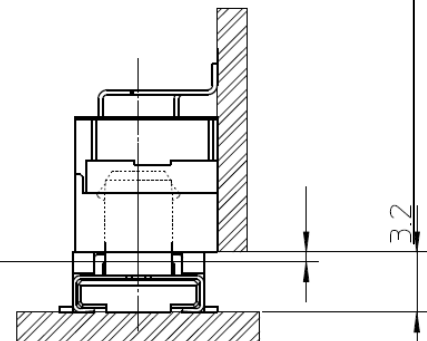

NUMBER GS-20-0355	TYPE <b>Application Specification</b>	<b>Amphenol FCI</b>	
TITLE BTFW series (1.0mm staggered pitch Board to Board connector)		PAGE 7 of 8	REVISION B
		AUTHORIZED BY S.Watanabe	DATE Sep./05/'18
CLASSIFICATION <b>UNRESTRICTED</b>			

#### 6.4 Hold on connector

P.C. board and metal plate must be fixed reliably by screw etc. after connector mating as the contact portion may be movement damage by adding to vibration and shock in practical use.

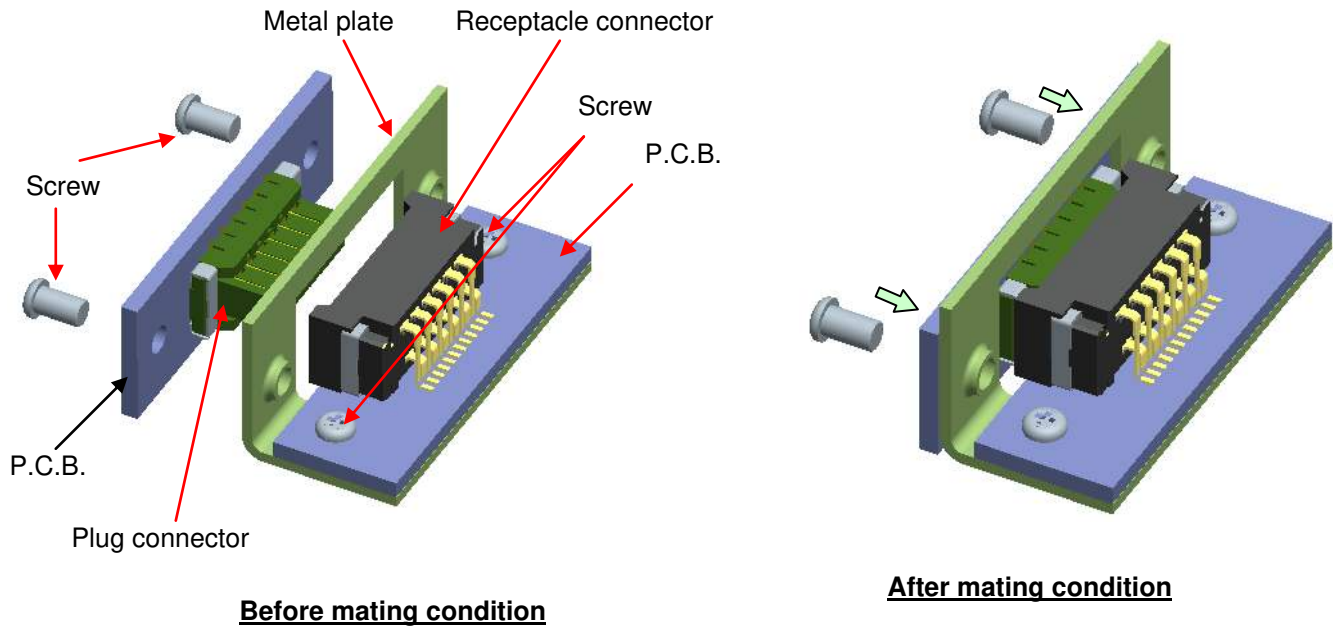

#### 7.0 Storage of connector

Please avoid the direct rays of the sun, dust, oil or moisture.

The soldering performance would be deteriorated if connectors are kept under high temperature/humidity condition for long time.

Storage recommendable conditions

Temperature : +5 ~ 40°C

Humidity : 10 ~ 75%RH

Periods : Within 6 month

NUMBER GS-20-0355	TYPE <b>Application Specification</b>	<b>Amphenol FCI</b>	
TITLE BTFW series (1.0mm staggered pitch Board to Board connector)		PAGE 8 of 8	REVISION B
		AUTHORIZED BY S.Watanabe	DATE Sep./05/'18
CLASSIFICATION <b>UNRESTRICTED</b>			

## 8.0 RECORD RETENTION

<u>REV</u>	<u>PAGE</u>	<u>DESCRIPTION</u>	<u>EC#</u>	<u>DATE</u>
A	All	New Release		Oct./01/'12
B	All	Format Change and Removed Japanese To Add Recommended conditions for mounted PCB Change storage conditions	ELX-J-31169	Sep./05/'18