

REVISIONS					
P	LTR	DESCRIPTION	DATE	DWN	APVD
D1		REVISED PER ECR-20-100645	02NOV2020	WH	DZ

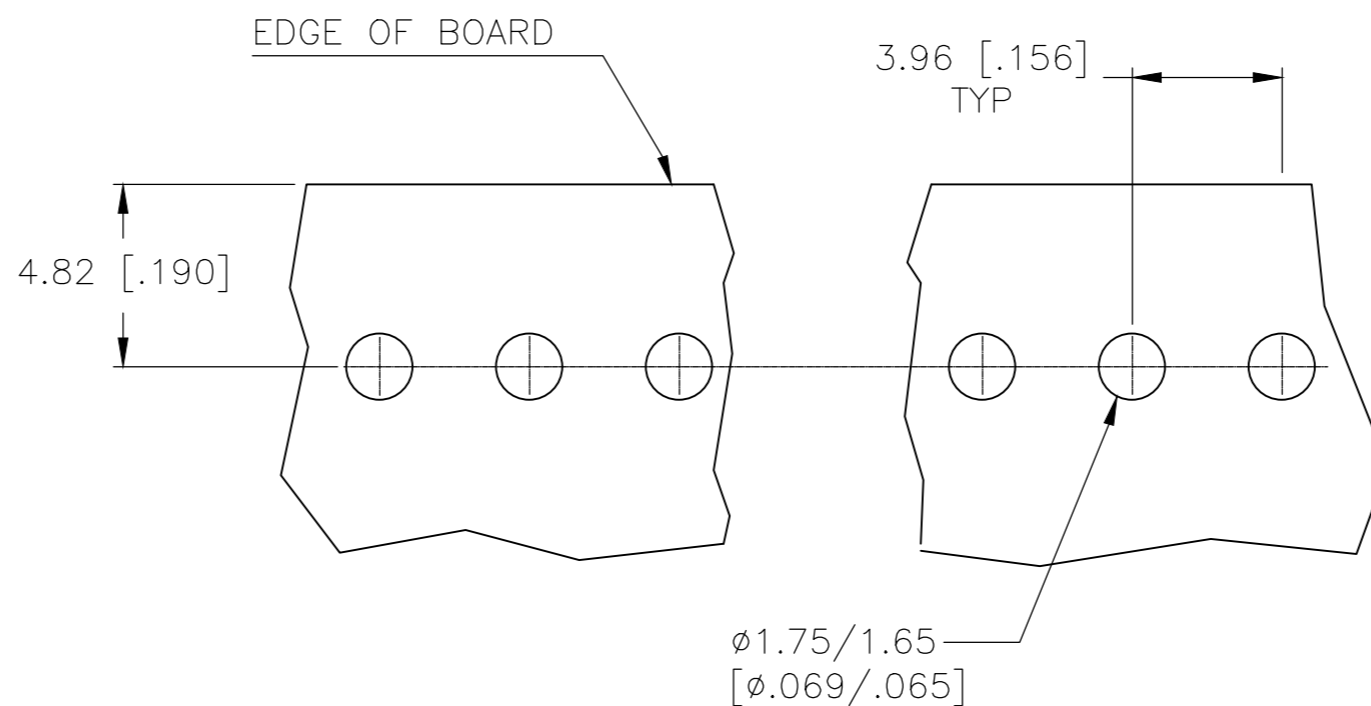

RECOMMENDED MOUNTING HOLE PATTERN FOR 1.60 [.063] THICK PC BOARD

- 1 HOUSING MATERIAL: NYLON, UL94 V0. PIN MATERIAL: BRASS.
- 2 PIN PLATING: 0.003 [.000120] MIN TIN OVER 0.001 [.000039] NICKEL.
- 3 COMPLY WITH GLOW WIRE REQUIREMENTS FOR PARTS OF NON-METALLIC MATERIAL SUPPORTING A CURRENT-CARRYING CONNECTION DETAILED IN IEC 60335-1, SECTION 30 (GWT).
- 4 PRODUCT BOW SHOULD MEET 0~0.08MM (INITIAL) AND 0~0.20MM(AFTER SOLDERABILITY)

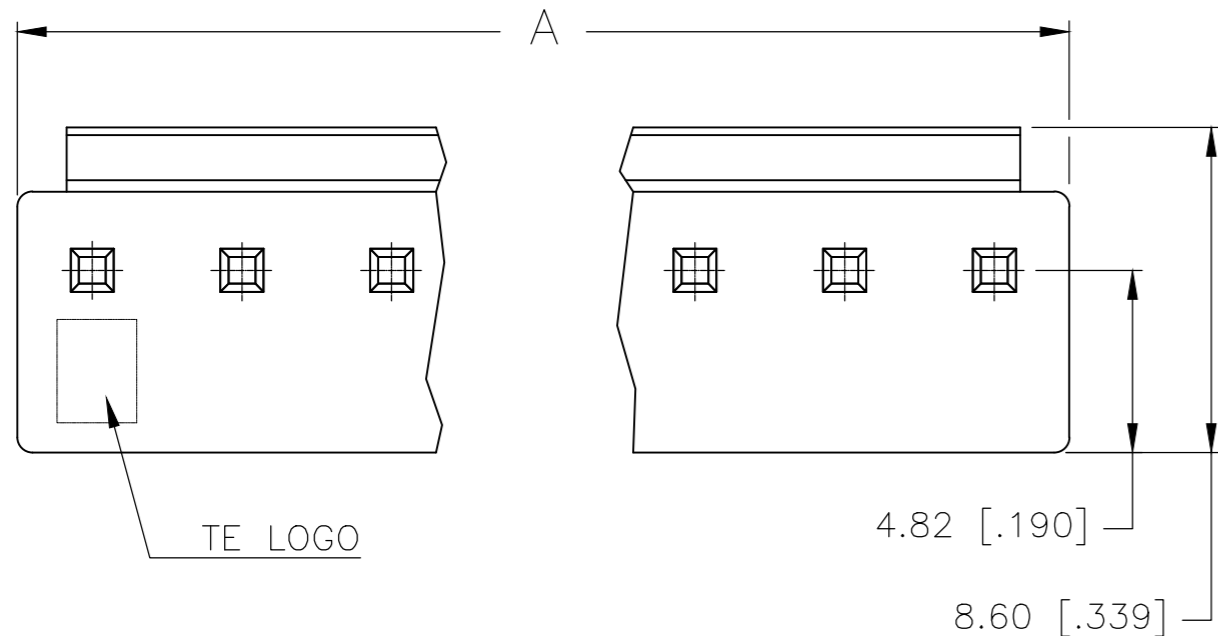
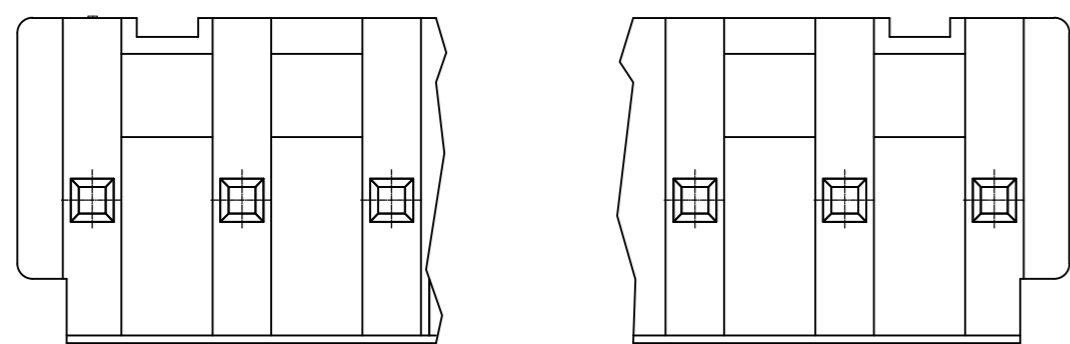
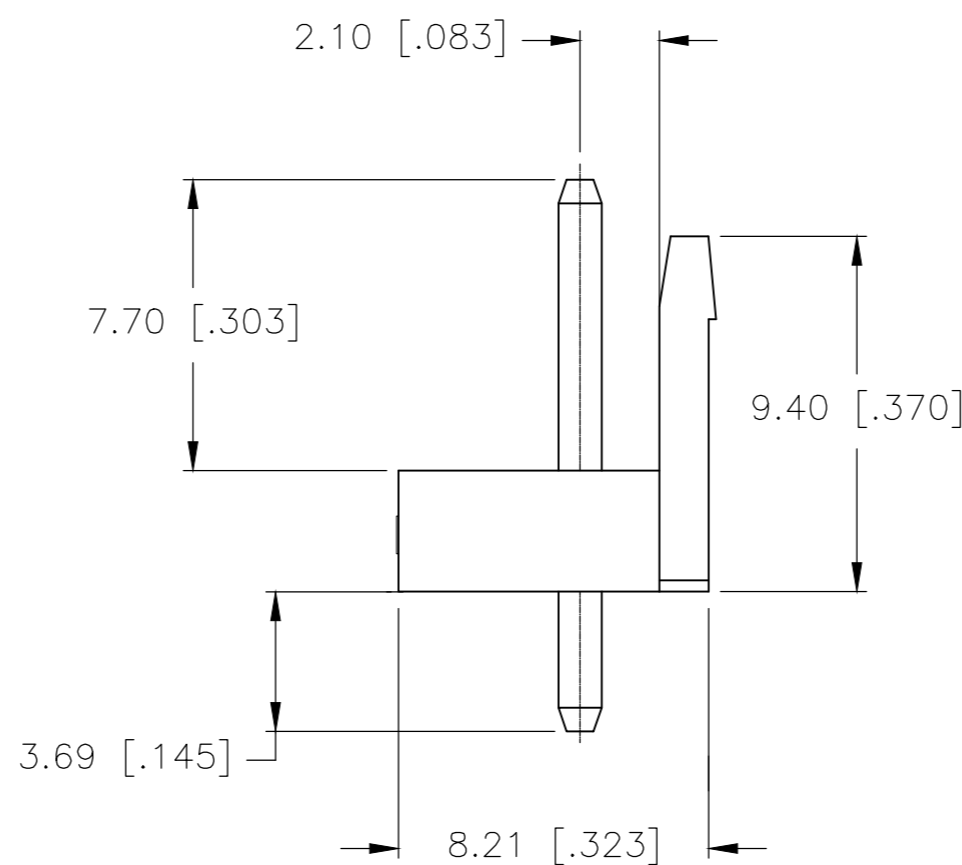
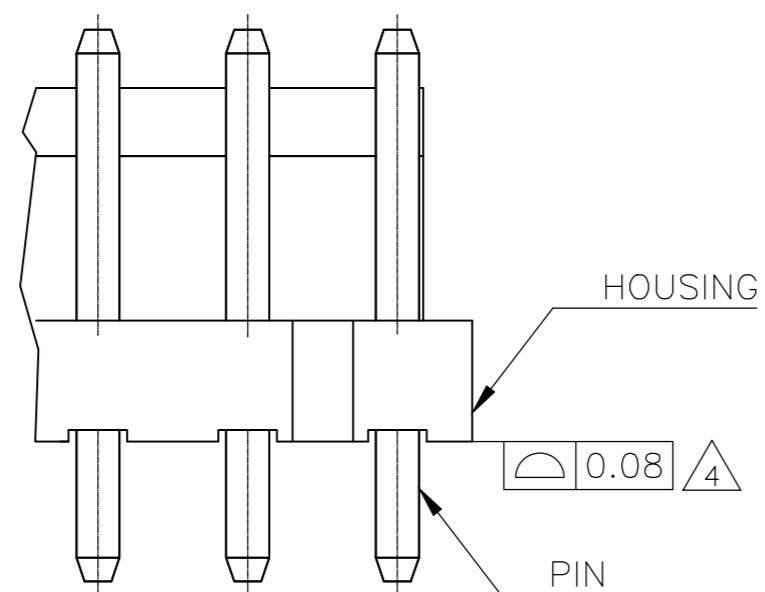
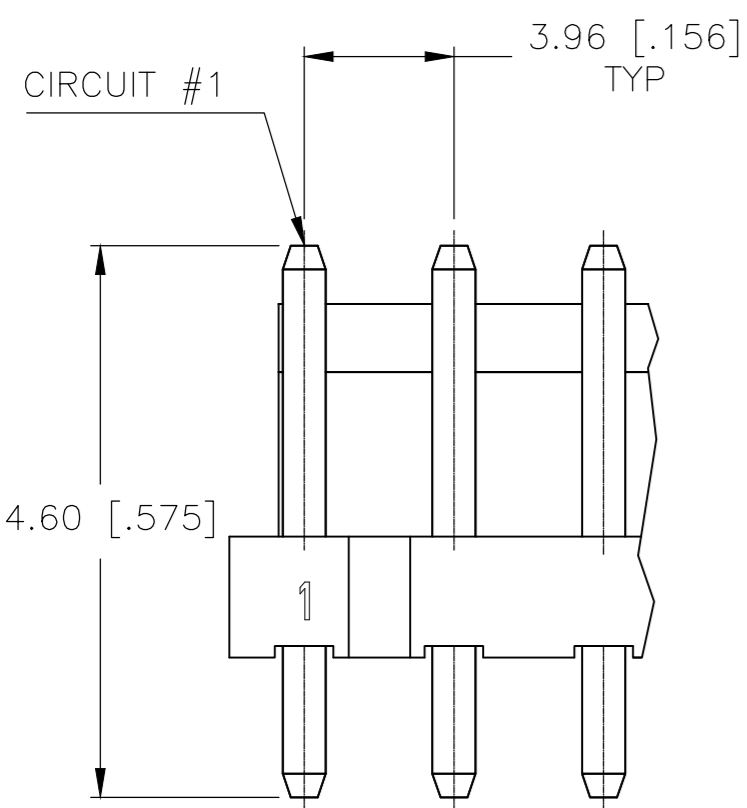

OMIT PIN #	NO. OF POSITIONS	COLOR	±0.30 [.012] DIM A	PART NUMBER
2, 5, 7	8	NATURAL	31.68 [1.247]	2-1744489-8
	9	NATURAL	35.64 [1.403]	1744489-9
	8	NATURAL	31.68 [1.247]	1744489-8
	7	NATURAL	27.72 [1.091]	1744489-7
	6	NATURAL	23.76 [0.935]	1744489-6
	5	NATURAL	19.80 [0.780]	1744489-5
	4	NATURAL	15.84 [0.624]	1744489-4
	3	NATURAL	11.88 [0.468]	1744489-3
	2	NATURAL	7.92 [0.312]	1744489-2

THIS DRAWING IS A CONTROLLED DOCUMENT.

DWN	JR RUTH	06FEB13
CHK	SAM MACE	09JAN12
APVD	SAM MACE	09JAN12
PRODUCT SPEC	108-5609	
APPLICATION SPEC		
WEIGHT	-	
CUSTOMER DRAWING		

STE TE Connectivity

HEADER ASSEMBLY-ECONOMY POWER VERTICAL

SIZE	A2	CAGE CODE	00779	DRAWING NO	C=1744489	RESTRICTED TO	-
SCALE	N/A	SHEET	1 OF 1	REV	D1		