

## NTC Heating Controller with Multi LEDs

### Features

- 5/6 steps heat temperature settings with 5 LEDs or 6 LEDs indicator
- Auto temperature control with NTC
- NTC open protection
- Pulse trigger for high current SCR / TRIAC (up to 15mA)
- Auto power off after exact 1 Hour heating(It is optional to disable.)
- Dual Voltage (120/240V 50/60Hz) operations (only PT8A3263-3266A/B/C available)
- Auto detect power supply Voltage (120V/240V) and frequency (50/60Hz)
- Internal 5V Zener
- DIP-16 and SOIC-16 package

### Applications

- Ceramic heating controller

### Pin Configuration

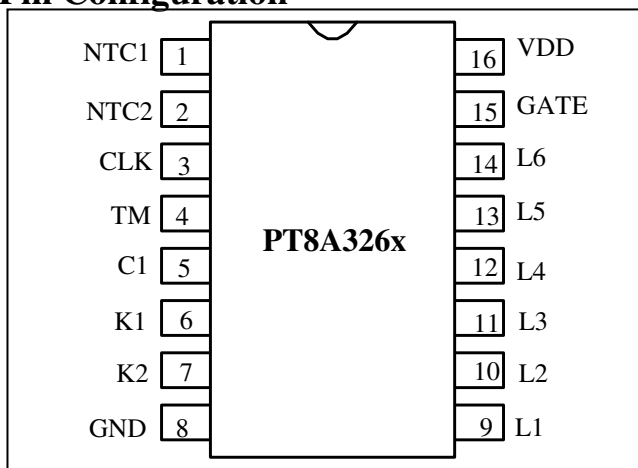

### Pin Description

Name	Pin No.	Type	Description
NTC1	1	I	NTC voltage input, NTC open detection input
NYC2	2	O	Output signal for NTC open detection
CLK	3	I	Clock input from power line
TM	4	I	Timer be disabled if tied ground
C1	5	O	ON state indicator / lock key indicator for 3267A/3268A
K1	6	I	UP, DOWN push button input
K2	7	I	ON/OFF push button input
L1~L6	9-14	O	Six temperature steps indicator LED1~LED6 output
GATE	15	O	TRIAC and SCR trigger output
GND	8	Ground	Ground
VDD	16	Power	Power Supply.

### Description

The PT8A3263/4/5/6/7/8 are mixed signal CMOS LSI chips specially designed for heating controller with the external NTC (Negative Temperature Component) sensor. NTC open protection is implemented for device safety and selectable 5 or 6 heating temperature levels.

PT8A3263/64 are for 5 step levels (eg.100°C, 120°C, 140°C, 160°C, 180°C) and PT8A3265/66 are for 6 step levels (eg. 100°C, 120°C, 140°C, 160°C, 180°C, 200°C). They can drive TRIAC or SCR directly and detect the heater's temperature with NTC sensor input. They have up/down keys for temperature setting, On/Off Key for heating on/off control and 3 LEDs display mode.

PT8A3267/68 have 6 step levels (eg.100°C, 120°C, 140°C, 160°C, 180°C, 200°C). They can drive TRIAC or SCR directly and detect the heater's temperature with NTC sensor input. They have up/down keys for temperature setting and On/Off Key for heating on/off control. They also have 1 second (2 seconds for PT8A3268A) delay function before go into off state and lock-key function. Their LEDs have special running flash mode (mode 4)

These devices can be used in both 120V and 240V power line system, as they can automatically adjust the heating power according to the power line voltage to avoid heating appliance damage or long heating time.

They have selectable build-in timer to enable/disable auto-power off function after turn on 1 hour and the timer is 1 hour both under 60Hz and 50Hz power supply.

## Maximum Ratings

Storage Temperature.....	-55°C to +150°C
Ambient Temperature with Power applied.....	-20°C to +85°C
Supply Voltage to Ground Potential (Input & V <sub>DD</sub> Only).....	-0.5V to +6.5V
Supply Voltage to Ground Potential (Outputs Only).....	-0.5V to +6.5V
DC Input Voltage.....	-0.5V to +6.5V
Input/Output Current.....	50mA
Input/Output Current (Pin VDD, VB only).....	200mA
Power Dissipation.....	500mW

**Note:**

Stresses greater than those listed under MAXIMUM RATINGS may cause permanent damage to the device. This is a stress rating only and functional operation of the device at these or any other conditions above those indicated in the operational sections of this specification is not implied. Exposure to absolute maximum rating conditions for extended periods may affect reliability.

## Recommended operation conditions

Sym	Parameter	Pin	Min	Typ	Max	Unit
V <sub>DD</sub>	Operating Voltage	VDD	4.0	V <sub>Z</sub>	-	V
T <sub>A</sub>	Operating temperature	-	-20	-	85	°C
F <sub>CLK</sub>	Frequency of CLK	CLK	-	50/60	-	Hz

## DC Electrical Characteristics

**DC Input Electrical Characteristics** (V<sub>DD</sub> = 4.5V, T<sub>A</sub> = -20 ~ 85°C, unless otherwise noted)

Symbol	Description	Test Conditions		Min	Type	Max	Unit	
		Level	Temp(°C)					
V <sub>T</sub> NTC1	Voltage of NTC1	Pin:NTC1 V <sub>DD</sub> =4.5V	1-half	90	1.083	1.103	1.123	V
			1	100	1.216	1.226	1.236	
			2-half	110	1.464	1.474	1.484	
			2	120	1.711	1.721	1.731	
			3-half	125	1.824	1.834	1.844	
			3	140	2.161	2.171	2.181	
			4-half	145	2.263	2.273	2.283	
			4	160	2.533	2.543	2.553	
			5-half	160	2.533	2.543	2.553	
			5	180	2.803	2.813	2.823	
			6-half	180	2.803	2.813	2.823	
			6	200	2.994	3.004	3.014	
I <sub>IH</sub>	Input high current	PIN:TM	V <sub>IN</sub> = V <sub>DD</sub>		-1	-	1	uA
		PIN: CLK	V <sub>IN</sub> = V <sub>DD</sub>		-	-	1	A
		PIN: NTC1	V <sub>IN</sub> = V <sub>DD</sub>		-100	-	100	nA
I <sub>IL</sub>	Input low current	PIN:TM	V <sub>IN</sub> = GND		-30	-40	-50	uA
		PIN: CLK	V <sub>IN</sub> = GND		-1	-	1	A
		PIN: NTC1	V <sub>IN</sub> = GND		-100	-	100	nA
R <sub>PULL-UP</sub>	Internal pull-up resistance	PIN: K1, K2	-		80	100	120	KΩ
R <sub>PULL-DOWN</sub>	Internal pull-down resistance	PIN: K1, K2	-		80	100	120	KΩ

### DC Output Electrical Characteristics

Symbol	Description	Test Conditions		Min	Type	Max	Unit
I <sub>OH</sub>	Output High Current	PIN: GATE	V <sub>DD</sub> = 4.5V	-15	-	-	mA
			V <sub>OUT</sub> = 2.5V				
		PIN: L1-L6	V <sub>DD</sub> = 4.5V	-4.0	-	-	
			V <sub>OUT</sub> = 4.0V				
		PIN: C1	V <sub>DD</sub> = 4.5V	-4.0	-	-	
			V <sub>OUT</sub> = 4.0V				
I <sub>OL</sub>	Output Low Current	PIN: GATE	V <sub>DD</sub> = 4.5V	4	-	-	mA
			V <sub>OUT</sub> = 0.5V				
		PIN: L1-L6	V <sub>DD</sub> = 4.5V	3	-	-	
			V <sub>OUT</sub> = 0.5V				
		PIN: C1	V <sub>DD</sub> = 4.5V	3	-	-	
			V <sub>OUT</sub> = 0.5V				
		PIN: NTC2	V <sub>DD</sub> = 4.5V	20	-	-	
			V <sub>OUT</sub> = 0.5V				

### Power Supply Characteristics

Symbol	Description	Test Conditions	Min	Type	Max	Unit
V <sub>POR</sub>	Voltage of POR	-	2.5	-	3.5	V
I <sub>DD</sub>	Current consumption	No loading, V <sub>DD</sub> = 4.5V	-	-	400	μA
V <sub>Z</sub>	Voltage of Zener	I <sub>DD</sub> = 500μA ~ 20mA	4.5	5.0	5.5	V
T <sub>PO</sub>	Power off timer	F <sub>CLK</sub> = 50/60Hz	54	60	66	Min

### Line Clock Synchronization Characteristics

Symbol	Description	Test Conditions		Min	Type	Max	Unit
V <sub>TCLK</sub>	Compare Threshold Voltage of CLK Pin	VT4	V <sub>CLK</sub> > V <sub>LEVEL</sub>	105	145	185	mV
				VT3	-100	-150	
		VT2	V <sub>CLK</sub> < V <sub>LEVEL</sub>	60	90	120	
				VT1	-40	-90	
V <sub>LEVEL</sub>	120V/240V Level Threshold Voltage of CLK Pin	V <sub>DD</sub> = 4.5V	1.69	1.88	2.07	V	

**Note:** The four comparators (VT1~VT4) have about 100mV hysteresis

### GATE Pulse Characteristics

Symbol	Description	Test Conditions	Min	Type	Max	Unit
Tal_Gate	Width of Gate trigger pulse	V <sub>DD</sub> = 4.0 ~ V <sub>Z</sub> ; T <sub>A</sub> = -20 ~ 85°C	270	300	330	μs

### Internal RC Oscillator Frequency Characteristics

Symbol	Description	Test Conditions	Min	Type	Max	Unit
Fosc	Frequency of RC Oscillator	V <sub>DD</sub> = 4.0 ~ V <sub>Z</sub> ; T <sub>A</sub> = -20 ~ 85°C	74.4	80	85.6	KHz
		V <sub>DD</sub> = 4.0 ~ V <sub>Z</sub> ; T <sub>A</sub> = 25°C	76	80	84	KHz

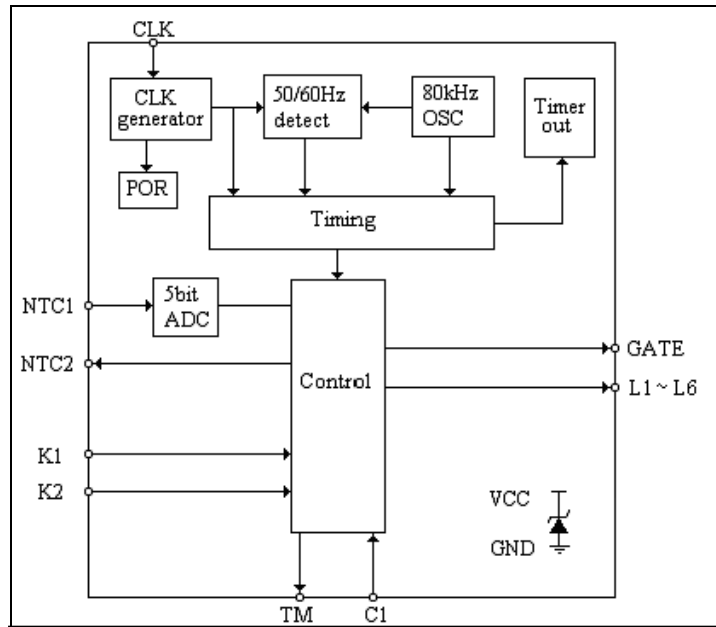
**Block Diagram**

## Functional Description

- **Input Button**

**For PT8A3263/64/65/66**

- 1) **Up button:** Temperature up adjustment. Push it once the temperature setting will increase one level until the highest level is reached.
- 2) **Down button:** Temperature down adjustment. Push Down button once, the temperature setting will reduce one level until the lowest level is reached.
- 3) **On/Off button:** This button is toggled on Heating-on state and Heating-off state.

For 1-key mode, this key will be set the temperature by loop:  
 Off→1→2→3→4→5→(6)→Off→

When power on IC first, the initial temperature setting is Level 4 (Internal option: Level1)

Delay function:

Heating-on & Heating-off has no delay

(Internal option: Heating-on has 0.5 second delay & Heating-off has 1 second delay).

- 4) **C1:** When in ON state, C1 output high.

**For PT8A3267A/68A**

- 1) **Up button:** Temperature up adjustment. Push Up button once, the temperature setting will increase one level until the highest level is reached.
- 2) **Down button:** Temperature down adjustment. Push Down button once, the temperature setting will reduce one level until the lowest level is reached.
- 3) **On/Off button:** This button is toggled on Heating-on state and Heating-off state.

PA8A3267A: When power on IC first, the initial temperature setting is Level 4

PA8A3268A: When power on IC first, the initial temperature setting is Level 6

If power is always on IC, the last setting temperature level will be memorized when push ON again

**Delay function:**

PT8A3267A: Heating-on has no delay & Heating-off has 1 second delay

PT8A3268A: Heating-on has no delay & Heating-off has 2 second delay

- 4) **C1: Lock key function**

- ◆ When in Heating-on state, after continuously push on/off key down twice( The interval is less than 600ms ), IC will lock current temperature level state and disable up/down and on/off function, C1 pin output high level
- ◆ When in lock state push on/off key down twice again, IC will unlock current temperature level state and enable up/down and on/off function, C1 pin output low level

- **LEDs indicator:**

LED1: Level 1 temperature setting ( eg. 100°C)

LED2: Level 2 temperature setting ( eg. 120°C)

LED3: Level 3 temperature setting ( eg. 140°C)

LED4: Level 4 temperature setting ( eg. 160°C)

LED5: Level 5 temperature setting ( eg. 180°C)

LED6: Level 6 temperature setting ( eg. 200°C, for PT8A3265/6x, PT8A3267A/68A)

- 1) **Mode 1**

Standby/Off state: LED1 ~ LED6 are all off

On State: The LED that be setting level is on.

- 2) **Mode 2**

Standby/Off state: LED1 ~ LED6 are all off

On state:

Heating up: The LED that be setting level is Flash. (Fclk/32)

Stable: This LED is on

Drop: This LED is on

- 3) **Mode 3**

Standby/Off state: LED1 ~ LED6 are all off

On state: The LED that be setting level and below the setting level are on.

- 4) **Mode 4**

Standby/Off state: LED1 ~ LED6 are all off

On state:

Level 1:

Heating up/ Drop: LED1 is flash (Fclk/32)

Stable: LED1 is on

Level2:

Heating up/ Drop: LED1 and LED2 is round flash (Fclk/16)

Stable: LED1 and LED2 are on

Level4 ~ Leve6: similar as upon

Note:

1. When in stable state, don't flash even if detect the below or over setting temperature(for mode2 and mode4)
2. When push up/down key, the setting LED will be on state for 1.5s before starting flashing(for mode2 and mode4)
3. When push up/down key, the setting LED will be forced to flash for 2.5s (for mode4)

- 5) **NTC open state**

The LED that relate with the setting temperature is fast flash (Fclk/8)

Disable up/down key function

If detect NTC is not open, recover working state

- 6) **LED drive style**

LED1-LED6: High pulse drive (50Hz)

C1: High level drive, PT8A3267/68A use pulse drive (50Hz)

- **Reset**

After power on, the chip will be reset by internal POR circuit, GATE, LED and C1 pins output low level and IC is in Standby state

- **Timer**

- ◆ Once IC enters Heating-on state, internal timer will start to count. It'll be timeout and auto heating-off after exact 1 hour both under 60Hz and 50Hz. This function can be disabled by Pin TM is tied to ground.
- ◆ The timer will be clear while push up/down key.

- **Control signal output**

When working in Heating-on state, Gate output will be related to NTC1 input and CLK input amplitude.

**Effect of NTC and  $V_{T_{CLK}}$  Level on GATE.**

Working State	CLK input voltage	NTC (NTC open detection)	NTC (Normal temp detection)	GATE (trigger to SCR/TRIAC)	
				A,B,C (suffix)	D,E,F (suffix)
ON	$V_{CLK} > V_{LEVE L}$ (220v)	$V_{NTCO} \sim V_{DD}$	Below 90% setting temperature	25%	100%
			Over 90% setting temperature	12.5%	50%
			Over setting temperature	0	0
	$V_{CLK} < V_{LEVE L}$ (110v)		Below 90% setting temperature	100%	100%
			Over 90% setting temperature	50%	50%
			Over setting temperature	0	0
Off	X*		X	0	0
X	X	$0 \sim V_{NTCO}$	X	0	0

\*Note: 1) X means any input.

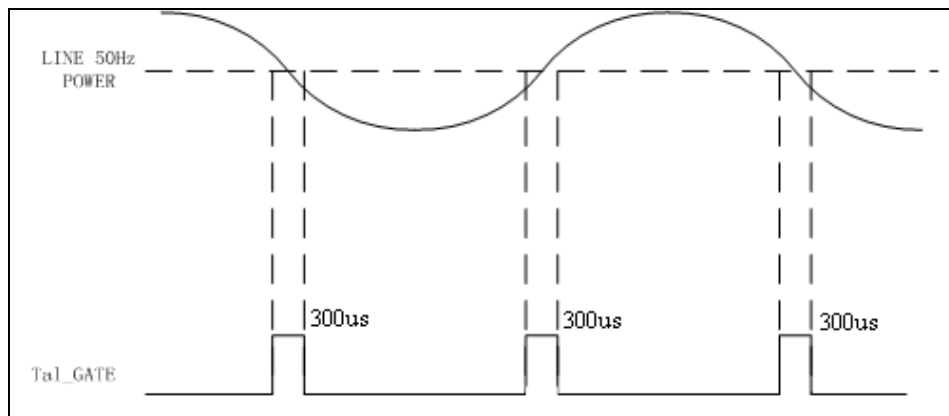
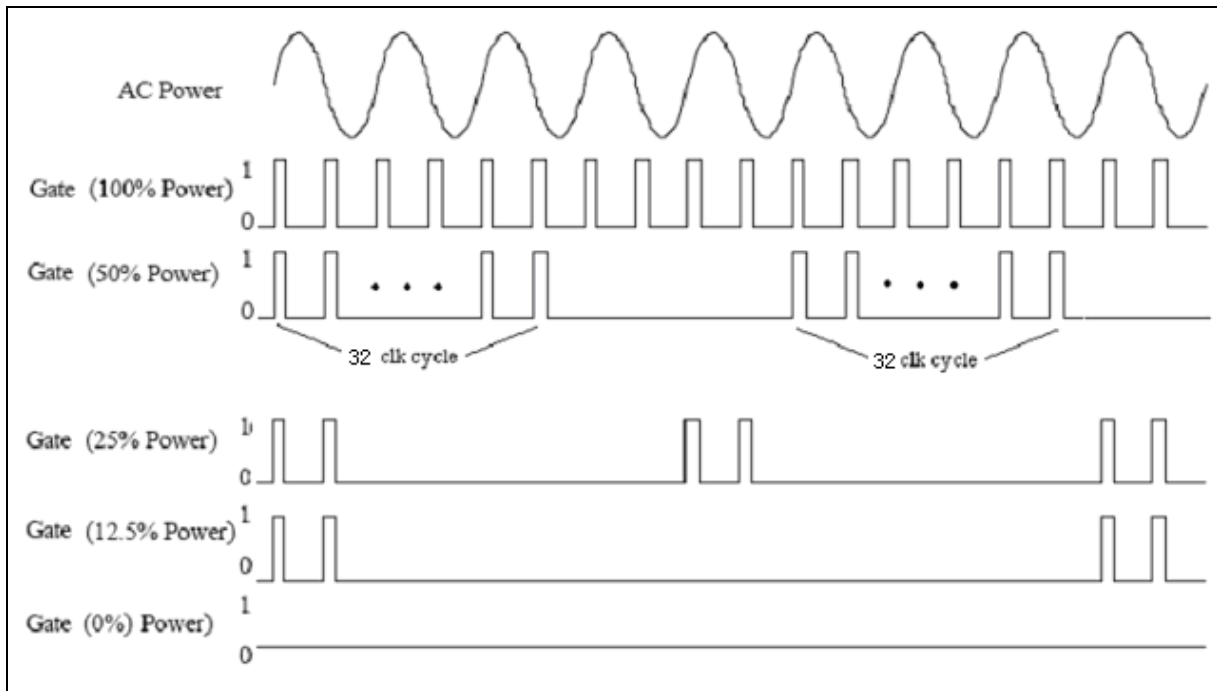
**Effect of NTC and Pulse Trigger on GATE**

- High trigger peak current (>15mA), enough trigger 15A triac
- Pulse triggering reduce the false self trigger by the leakage of triac at high temperature environment.
- Tal\_GATE = 300us (**Internal option:** 600us, 900us)
- 120VAC input, under half power state, the minimum heating-period is 32 cycles (**Internal options:** 8, 16, 32, 64 cycles)
- The drive pulse present at both positive edge and negative edge (**Internal option:** only positive edge)

### Application Circuit

Application circuit for PT8A3263A/B/D/E

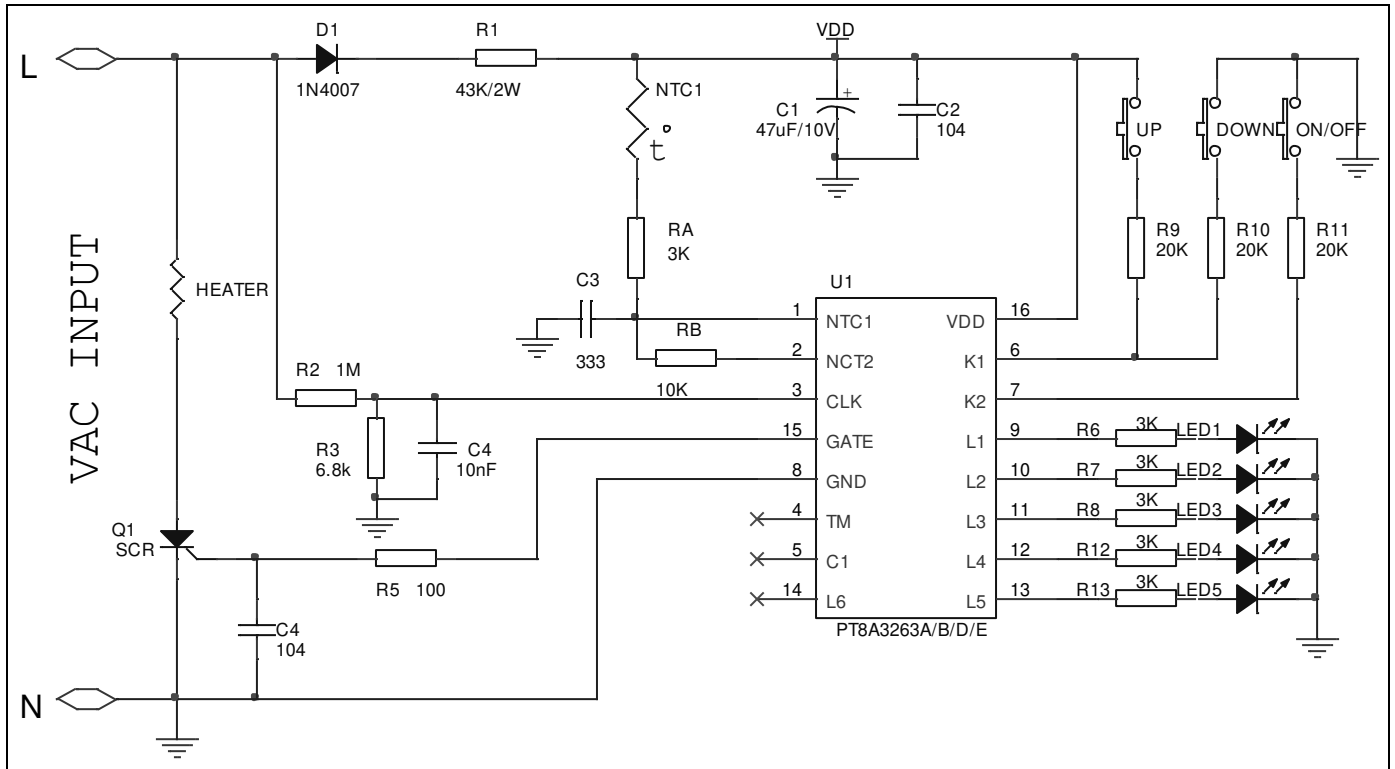

Application circuit for PT8A3263C/F

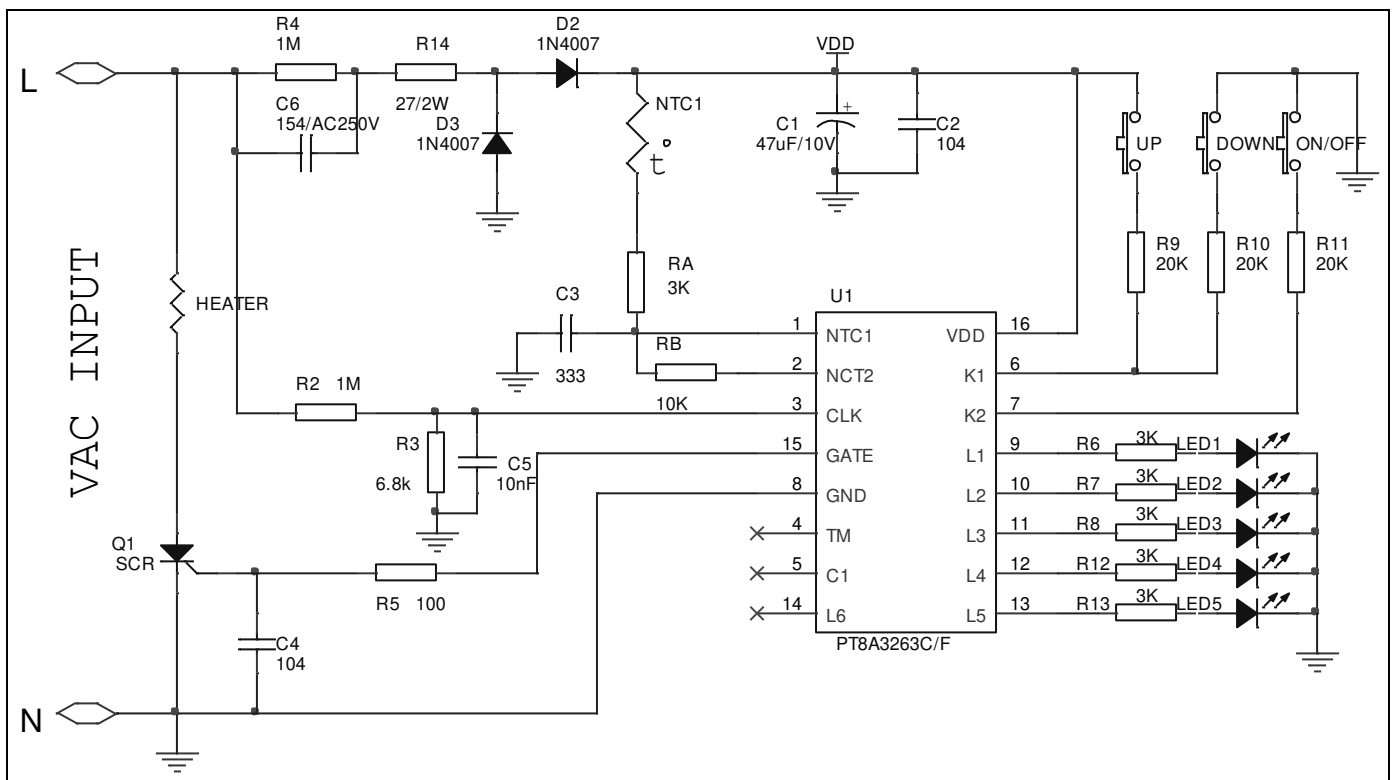



Application circuit for PT8A3264A/B/D/E

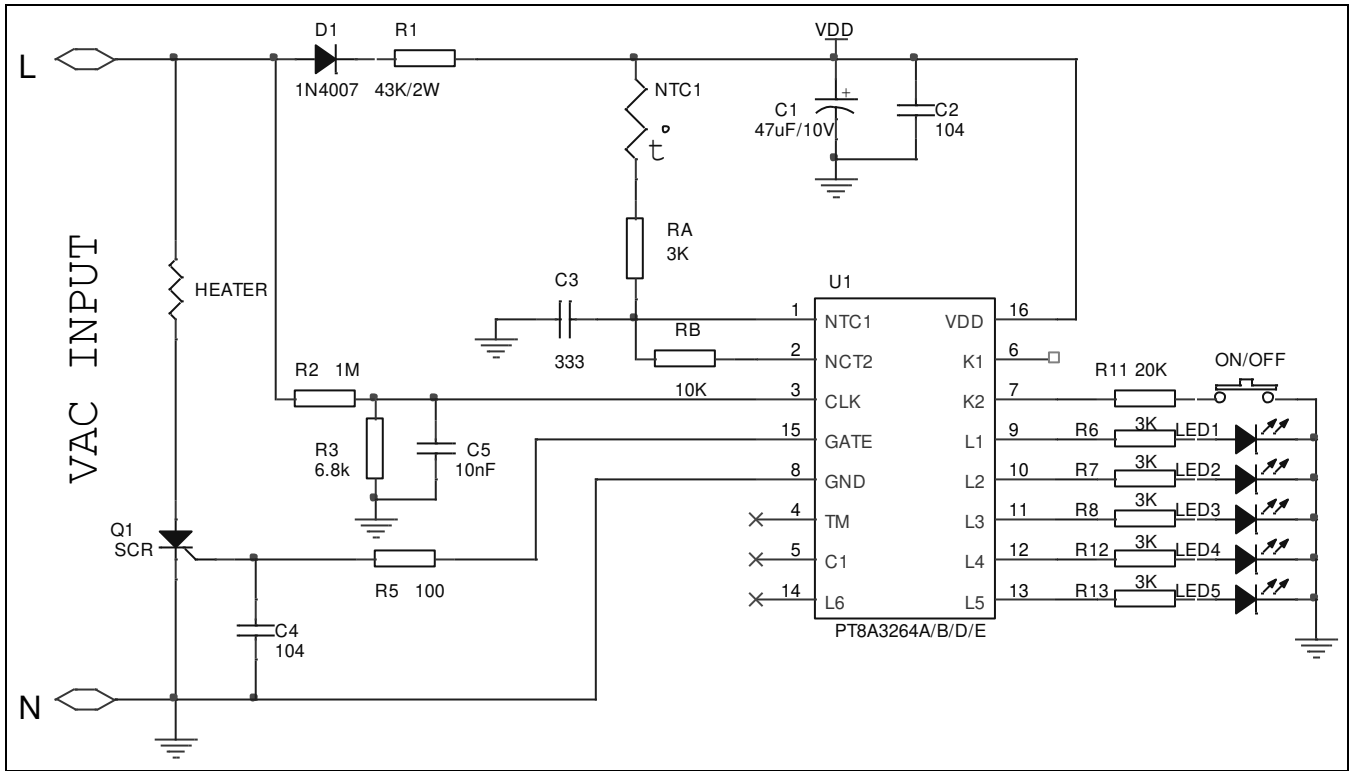

Application circuit for PT8A3264C/F

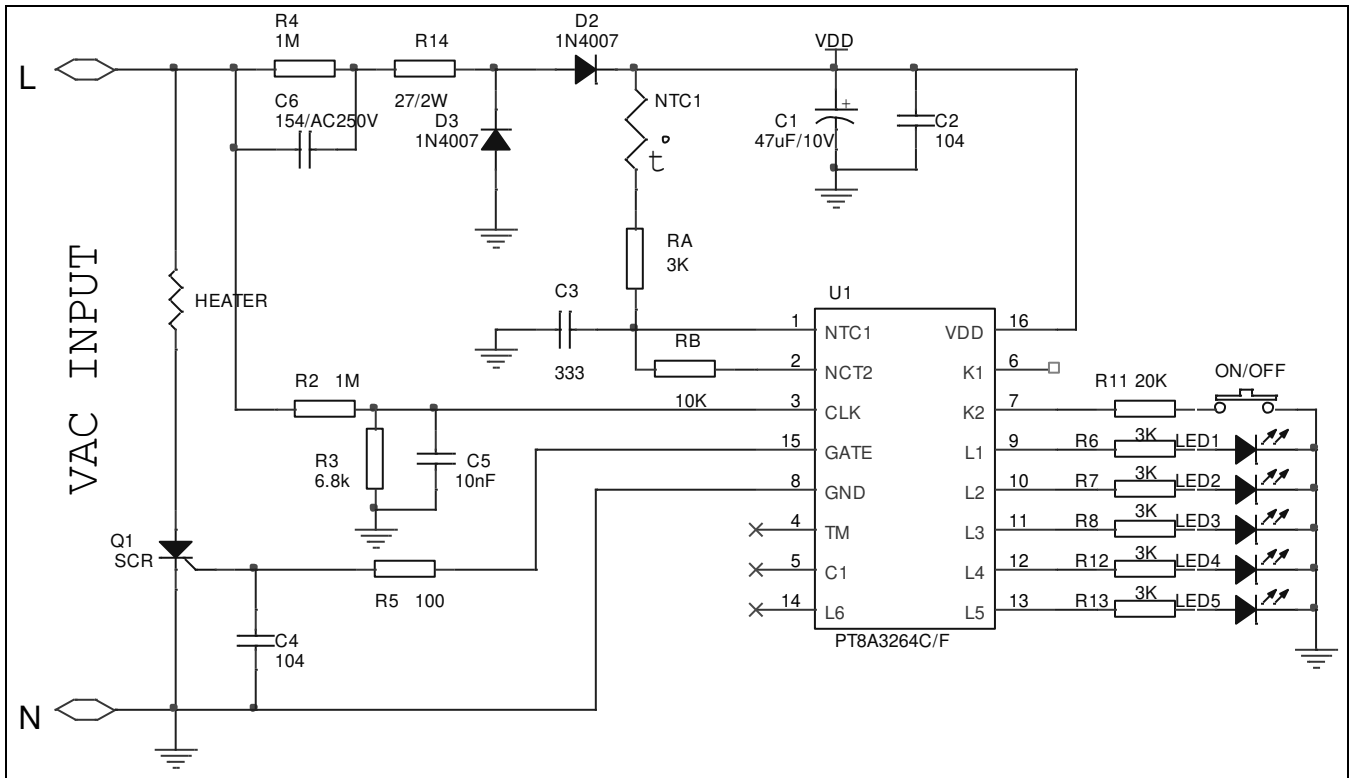

Application circuit for PT8A3265A/B/D/E

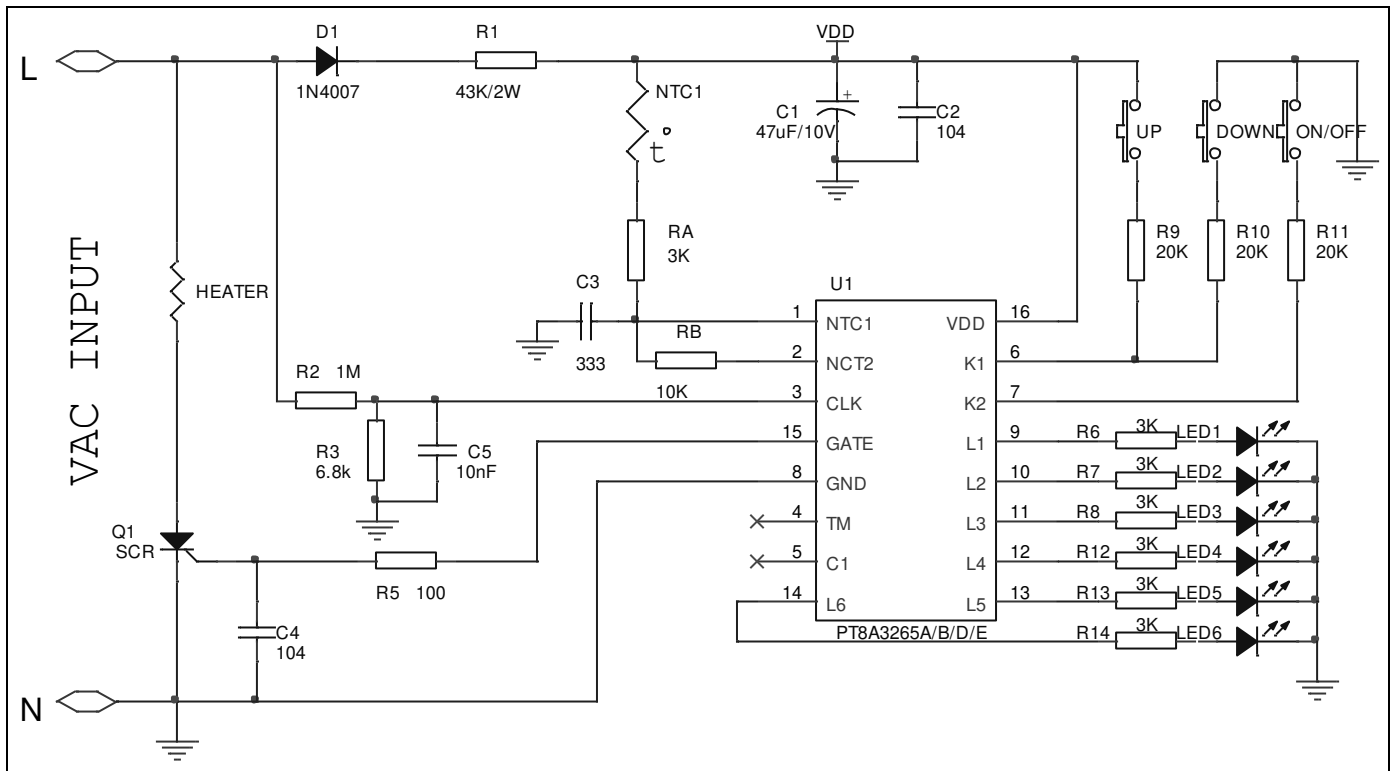

Application circuit for PT8A3265C/F

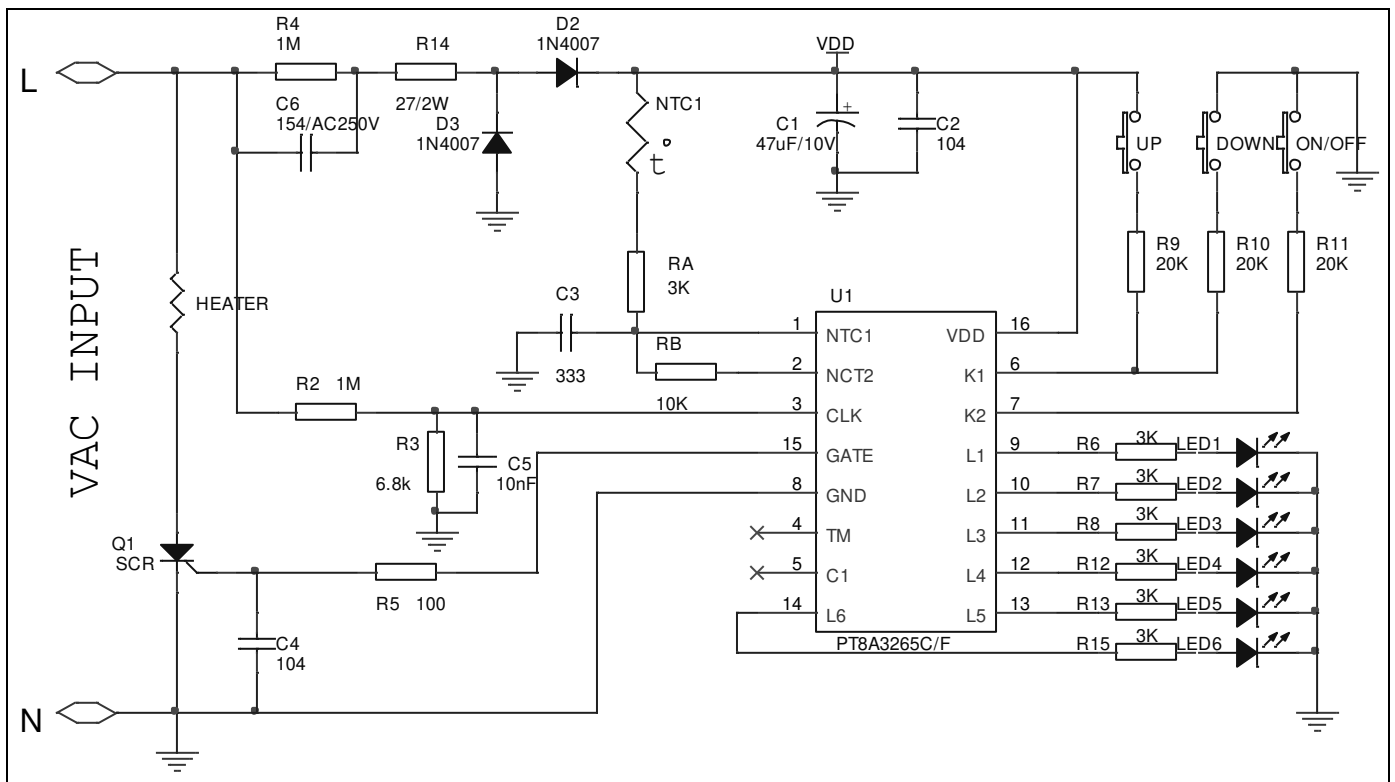

Application circuit for PT8A3266A/B/D/E

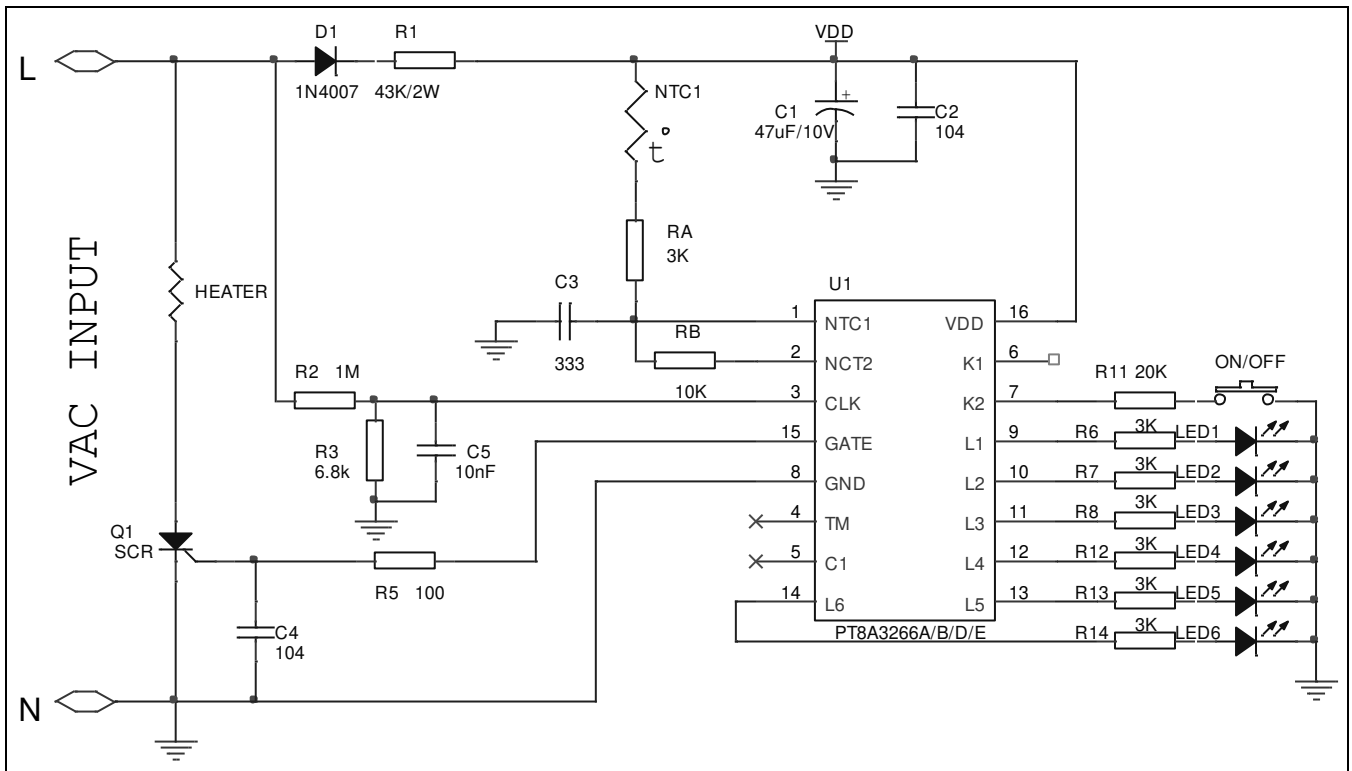

Application circuit for PT8A3266C/F

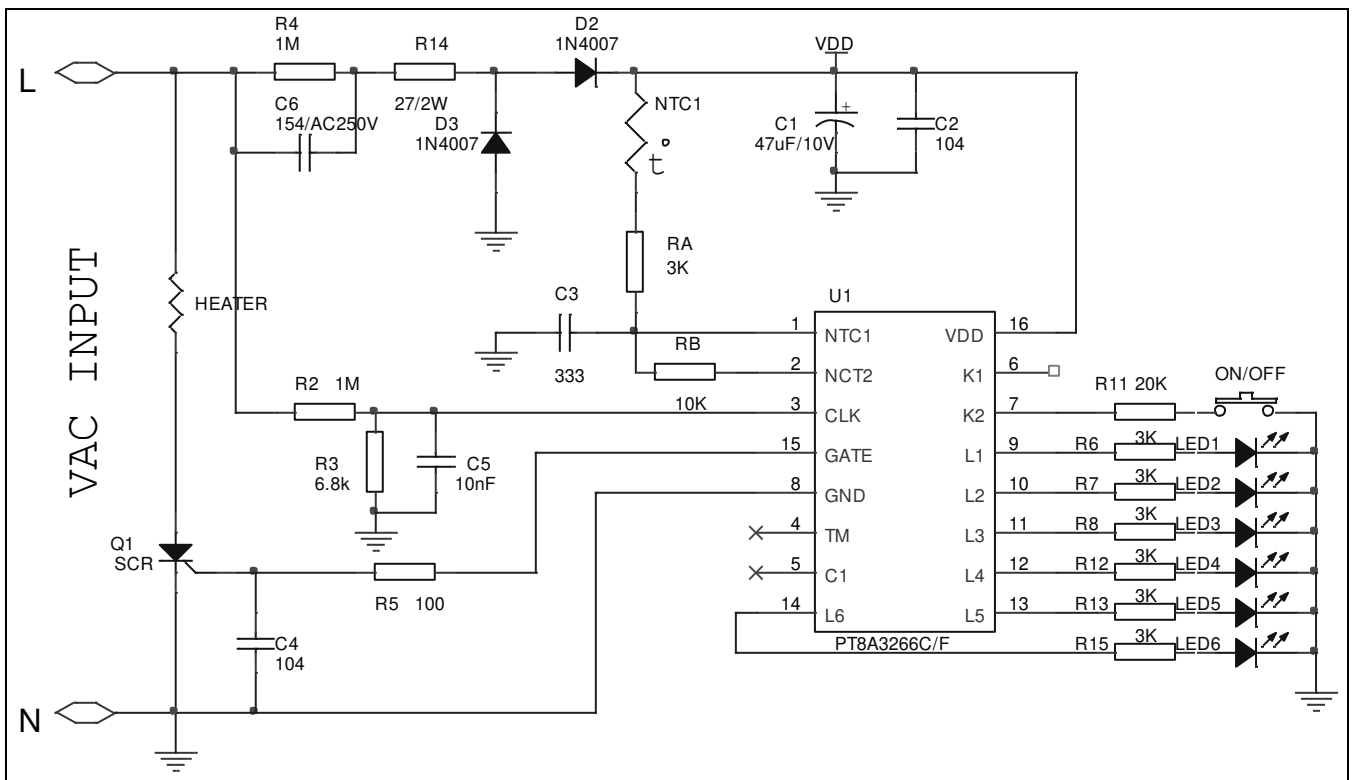

Application circuit for PT8A3267A/68A

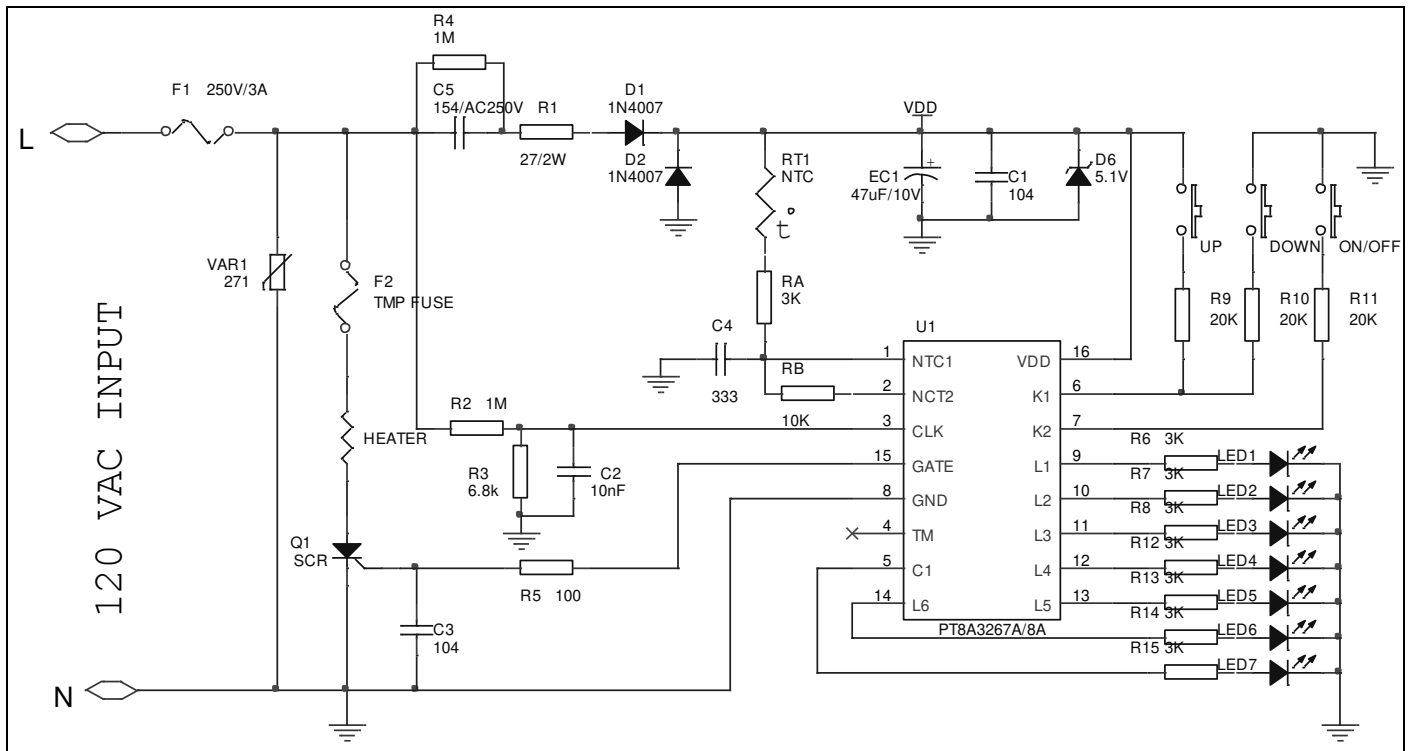

**Mechanical Information**

PE (DIP-16)

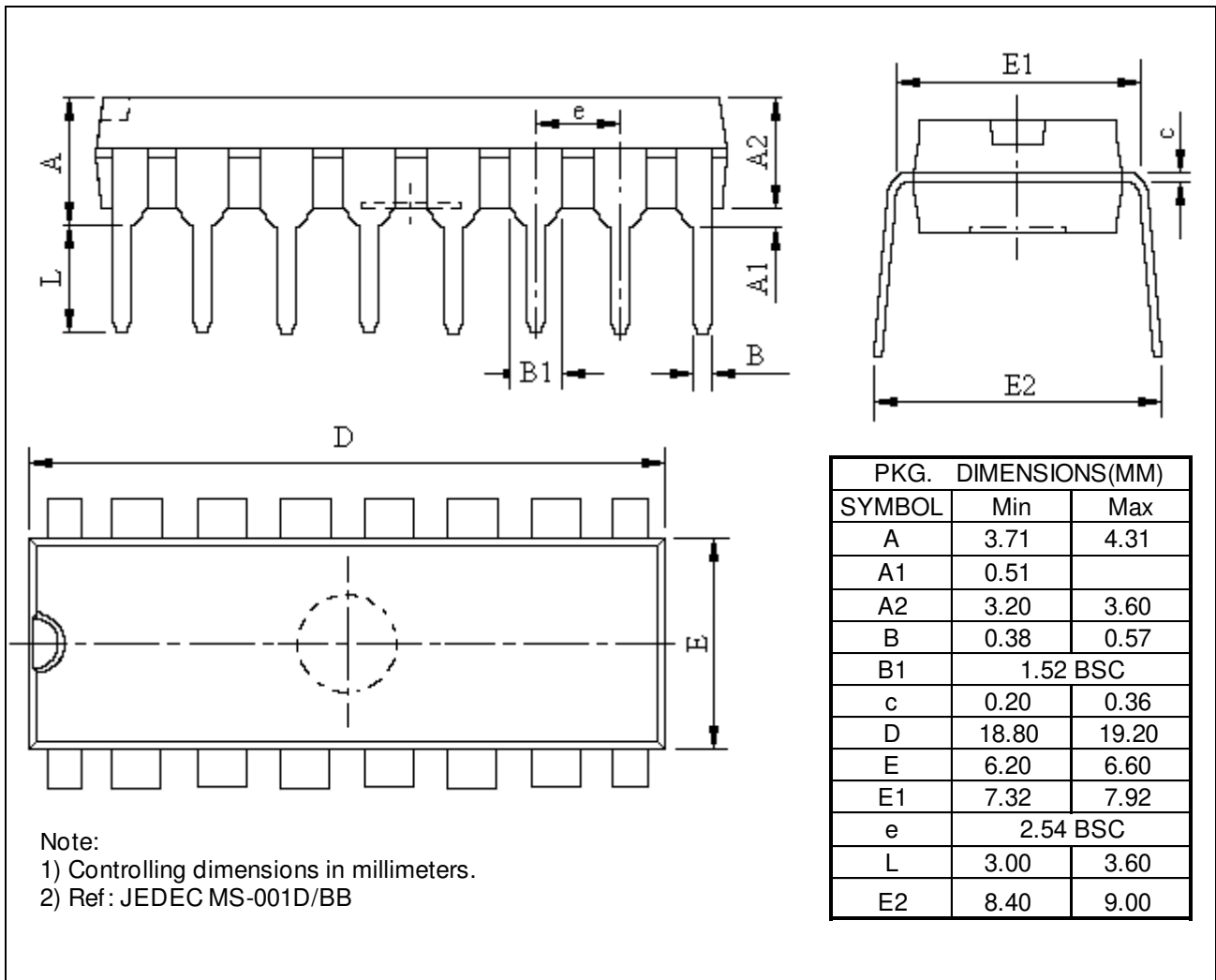

WE (SOIC-16)

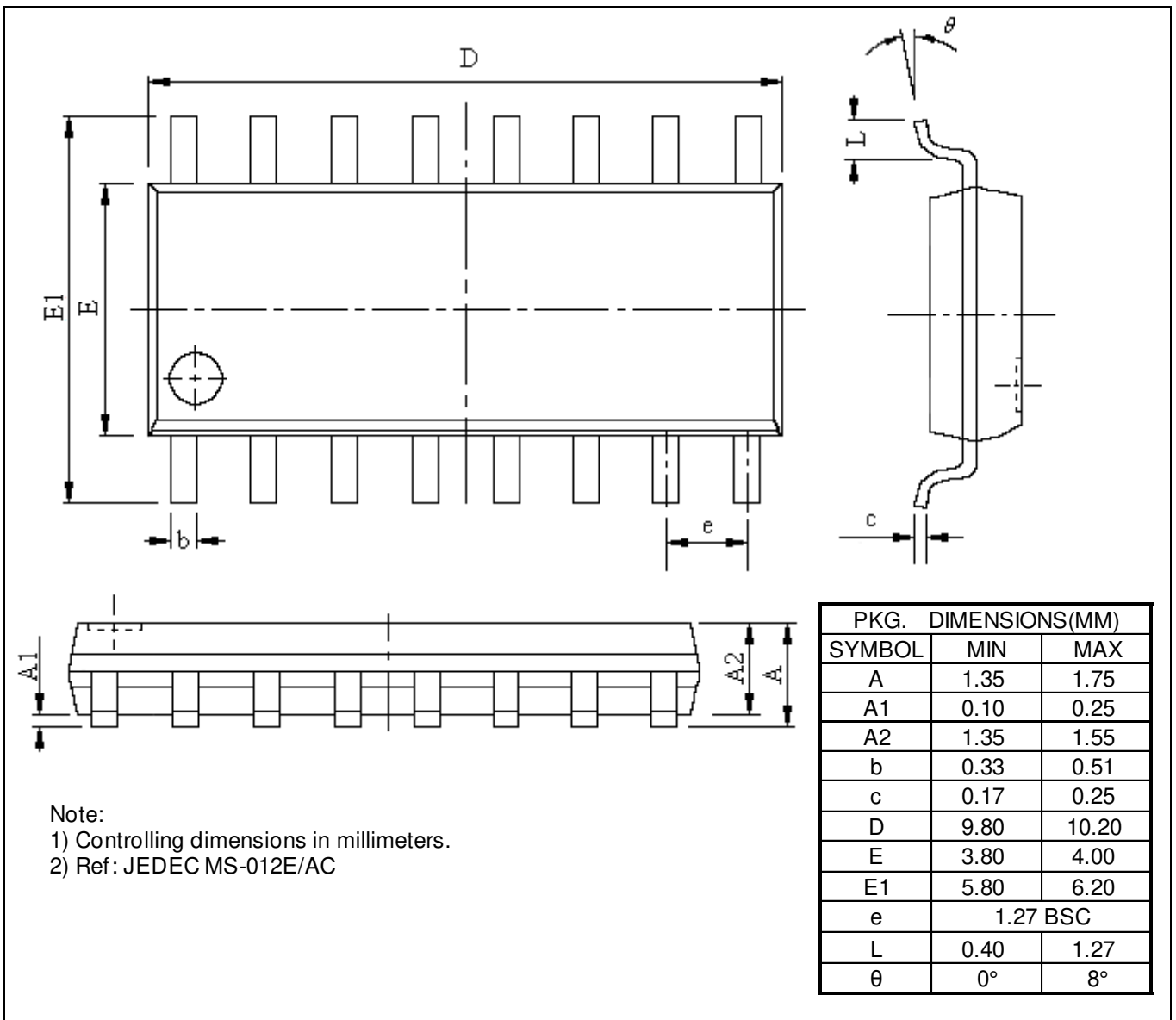

## Ordering Information

Ordering No.	Package Code	Package
PT8A326xXPE	P	Lead free 16-pin DIP
PT8A326xXWE	W	Lead free 16-pin SOIC
PT8A3267APE	P	Lead free 16-pin DIP
PT8A3267AWE	W	Lead free 16-pin SOIC
PT8A3268APE	P	Lead free 16-pin DIP
PT8A3268AWE	W	Lead free 16-pin SOIC

**Note:**

- “x” shows 0~4 and “X” shows A-F with different function. See *Function Comparison Table*.
- E = Pb-free
- Adding X Suffix= Tape/Reel

## Function Comparison Table

P/N	Temp. Levels		Key Mode		LED mode**			Dual voltage	
	5 Steps	6 Steps	3-key	1-key	Mode 1	Mode 2	Mode 3	Y	N
3263A	√	-	√	-	√	-	-	√	-
3263B	√	-	√	-	-	√	-	√	-
3263C*	√	-	√	-	-	-	√	√	-
3263D*	√	-	√	-	√	-	-	-	√
3263E*	√	-	√	-	-	√	-	-	√
3263F*	√	-	√	-	-	-	√	-	√
3264A*	√	-	-	√	√	-	-	√	-
3264B*	√	-	-	√	-	√	-	√	-
3264C*	√	-	-	√	-	-	√	√	-
3264D*	√	-	-	√	√	-	-	-	√
3264E*	√	-	-	√	-	√	-	-	√
3264F*	√	-	-	√	-	-	√	-	√
3265A*	-	√	√	-	√	-	-	√	-
3265B*	-	√	√	-	-	√	-	√	-
3265C*	-	√	√	-	-	-	√	√	-
3265D*	-	√	√	-	√	-	-	-	√
3265E*	-	√	√	-	-	√	-	-	√
3265F*	-	√	√	-	-	-	√	-	√
3266A*	-	√	-	√	√	-	-	√	-
3266B*	-	√	-	√	-	√	-	√	-
3266C*	-	√	-	√	-	-	√	√	-
3266D*	-	√	-	√	√	-	-	-	√
3266E*	-	√	-	√	-	√	-	-	√
3266F*	-	√	-	√	-	-	√	-	√
3267A*	-	√	√***	-	Mode 4			√	-
3268A*	-	√	√***	-	Mode 4			√	-

- Note**
- \*: Contact Pericom for availability
  - \*\*: LED mode description see *Functional Description*, Page 4.
  - \*\*\*: PT8A3267A key mode is 3-key+delay+lock key(Heating off has 1s delay and lock-key function). PT8A3268A key mode is 3-key+delay+lock-key(Heating off has 2s delay and lock-key function).

Pericom Semiconductor Corporation • 1-800-435-2336 • [www.pericom.com](http://www.pericom.com)

Pericom reserves the right to make changes to its products or specifications at any time, without notice, in order to improve design or performance and to supply the best possible product. Pericom does not assume any responsibility for use of any circuitry described other than the circuitry embodied in Pericom product. The company makes no representations that circuitry described herein is free from patent infringement or other rights, of Pericom.