

2 x 35W dual/quad power amplifier for car radio

1 FEATURES

- HIGH OUTPUT POWER CAPABILITY:
 - 2 x 40W max./4Ω
 - 2 x 35W/4Ω EIAJ
 - 2 x 35W/4Ω EIAJ
 - 2 x 25W/4Ω @ 14.4V, 1KHz, 10%
 - 4 x 7W/4Ω @ 14.4V, 1KHz, 10%
 - 4 x 12W/2Ω @ 14.4V, 1KHz, 10%
- MINIMUM EXTERNAL COMPONENTS COUNT:
 - NO BOOTSTRAP CAPACITORS
 - NO BOUCHEROT CELLS
 - INTERNALLY FIXED GAIN (26dB BTL)
- ST-BY FUNCTION (CMOS COMPATIBLE)
- NO AUDIBLE POP DURING ST-BY OPERATIONS
- DIAGNOSTICS FACILITY FOR:
 - CLIPPING
 - OUT TO GND SHORT
 - OUT TO V_S SHORT
 - SOFT SHORT AT TURN-ON
 - THERMAL SHUTDOWN PROXIMITY

Figure 1. Package

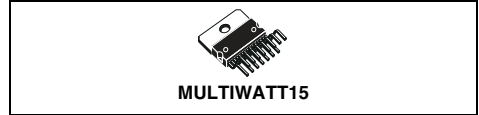

Table 1. Order Codes

Part Number	Package
TDA7375V	MULTIWATT 15 (Vertical)

2 PROTECTIONS:

- OUPUT AC/DC SHORT CIRCUIT
 - TO GND
 - TO V_S
 - ACROSS THE LOAD
- SOFT SHORT AT TURN-ON
- OVERRATING CHIP TEMPERATURE WITH
- SOFT THERMAL LIMITER
- LOAD DUMP VOLTAGESURGE
- VERY INDUCTIVE LOADS
- FORTUITOUS OPEN GND
- REVERSED BATTERY
- ESD

Figure 2. Block Diagram

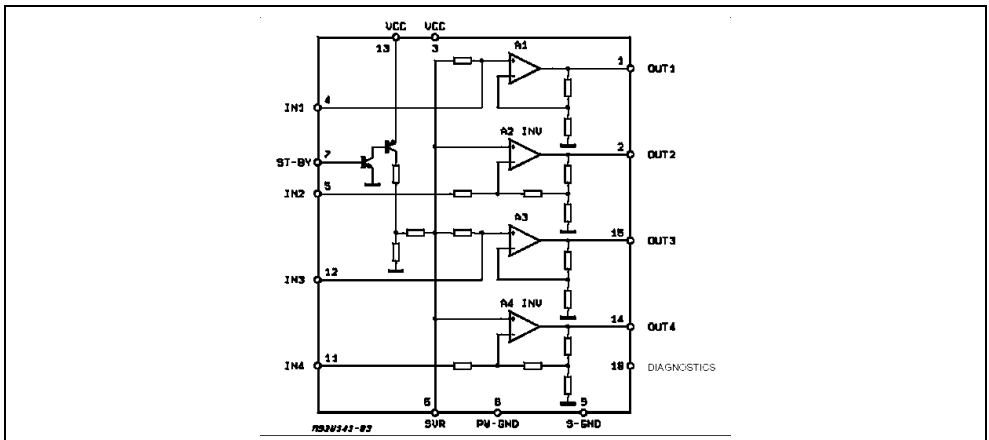

3 DESCRIPTION

The TDA7375V is a new technology class AB car radio amplifier able to work either in DUAL BRIDGE or QUAD SINGLE ENDED configuration.

The exclusive fully complementary structure of the output stage and the internally fixed gain guarantees the highest possible power performances with extremely reduced component count.

The on-board clip detector simplifies gain compression operation. The fault diagnostics makes it possible to detect mistakes during car radio set assembly and wiring in the car.

Table 2. Absolute Maximum Ratings

Symbol	Parameter	Value	Unit
V _{op}	Operating Supply Voltage	18	V
V _S	DC Supply Voltage	28	V
V _{peak}	Peak Supply Voltage (for t = 50ms)	50	V
I _O	Output Peak Current (not repetitive t = 100µs)	4.5	A
I _O	Output Peak Current (repetitive f > 10Hz)	3.5	A
P _{tot}	Power Dissipation (T _{case} = 85°C)	36	W
T _{stg} , T _j	Storage and Junction Temperature	-40 to 150	°C

Table 3. Thermal Data

Symbol	Parameter	Value	Unit
R _{th j-case}	Thermal Resistance Junction-case	max 1.8	°C/W

Figure 3. Pin Connection (Top view)

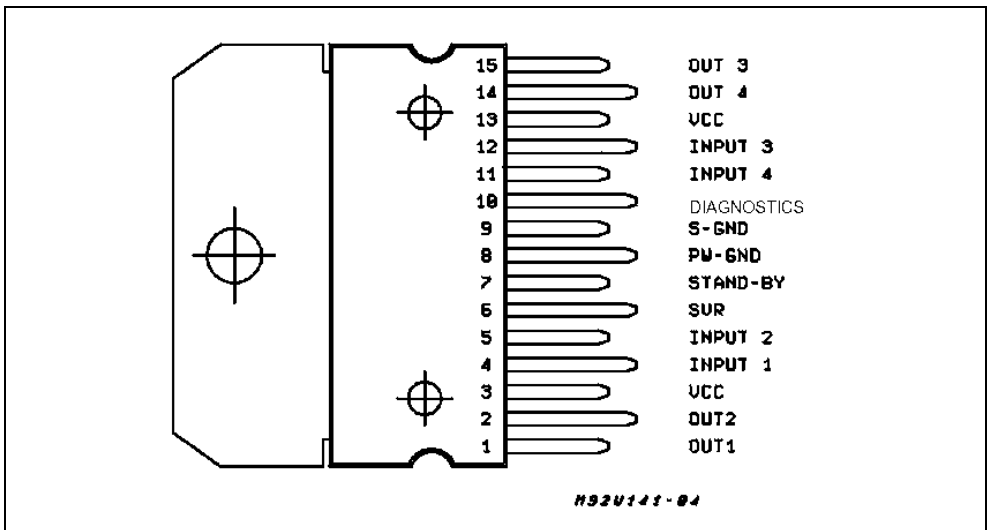

Table 4. Electrical Characteristics (Refer to the test circuit, $V_S = 14.4V$; $R_L = 4\Omega$; $f = 1KHz$; $T_{amb} = 25^\circ C$, unless otherwise specified)

Symbol	Parameter	Test Condition	Min.	Typ.	Max.	Unit
V_S	Supply Voltage Range		8		18	V
I_d	Total Quiescent Drain Current	$R_L = \infty$			150	mA
V_{OS}	Output Offset Voltage				150	mV
P_O	Output Power	THD = 10%; $R_L = 4\Omega$ Bridge Single Ended Single Ended, $R_L = 2\Omega$	23 6.5	25 7 12		W W W
$P_{O\ max}$	Max. Output Power (***)	$V_S = 14.4V$, Bridge	36	40		W
$P_{O\ EIAJ}$	EIAJ Output Power (***)	$V_S = 13.7V$, Bridge	32	35		W
THD	Distortion	$R_L = 4\Omega$ Single Ended, $P_O = 0.1$ to 4W Bridge, $P_O = 0.1$ to 10W		0.02 0.03	0.3	% %
CT	Cross Talk	$f = 1KHz$ Single Ended		70		dB
		$f = 10KHz$ Single Ended		60		dB
		$f = 1KHz$ Bridge	55			dB
		$f = 10KHz$ Bridge		60		dB
R_{IN}	Input Impedance	Single Ended	20	30		$K\Omega$
		Bridge	10	15		$K\Omega$
G_V	Voltage Gain	Single Ended	19	20	21	dB
		Bridge	25	26	27	dB
G_V	Voltage Gain Match				0.5	dB
E_{IN}	Input Noise Voltage	$R_g = 0$; "A" weighted, S.E. Non Inverting Channels Inverting Channels		2 5		μV μV
		Bridge $R_g = 0$; 22Hz to 22KHz		3.5		μV
SVR	Supply Voltage Rejection	$R_g = 0$; $f = 300Hz$	50			dB
A_{SB}	Stand-by Attenuation	$P_O = 1W$	80	90		dB
I_{SB}	ST-BY Current Consumption	$V_{ST-BY} = 0$ to 1.5V			100	μA
V_{SB}	ST-BY In Threshold Voltage				1.5	V
V_{SB}	ST-BY Out Threshold Voltage		3.5			V
I_{pin7}	ST-BY Pin Current	Play Mode $V_{pin7} = 5V$			50	μA
		Max Driving Curr. Under Fault (*)			5	mA
$I_{cd\ off}$	Clipping Detector Output Average Current	$d = 1\%$ (**)		90		μA
$I_{cd\ on}$	Clipping Detector Output Average Current	$d = 5\%$ (**)		160		μA
$V_{sat\ pin10}$	Voltage Saturation on pin 10	Sink Current at Pin 10 = 1mA			0.7	V

(*) See built-in S/C protection description

(**) Pin 10 Pulled-up to 5V with 10K Ω ; $R_L = 4\Omega$

(***) Saturated square wave output.

4 STANDARD TEST AND APPLICATION CIRCUIT

Figure 4. Quad Stereo

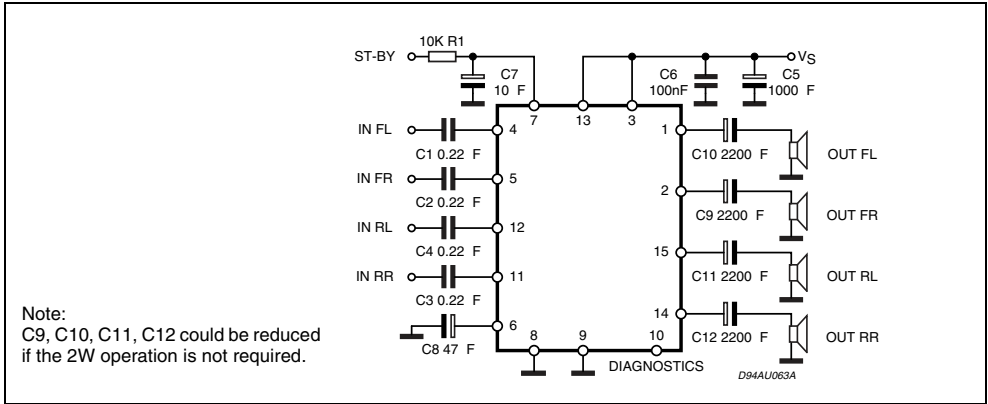

Figure 5. Double Bridge

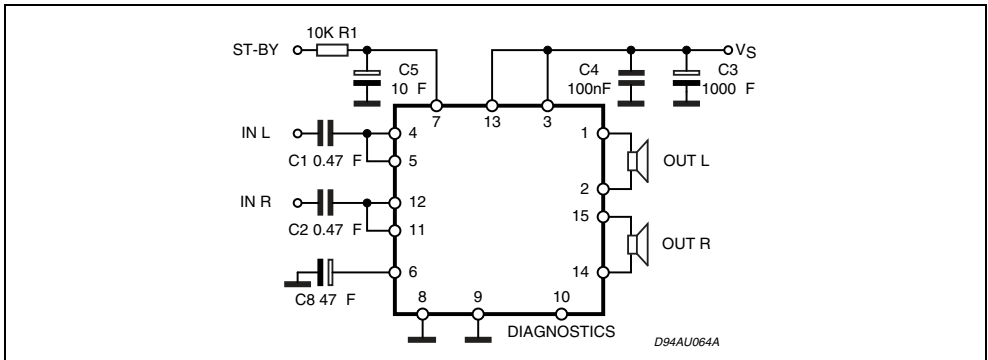

Figure 6. Stereo/Bridge

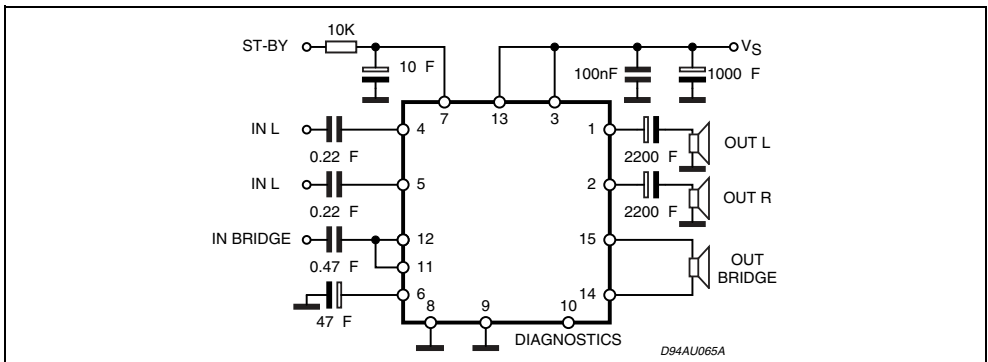

Figure 7. P.C. Board and Component Layout of the fig.4

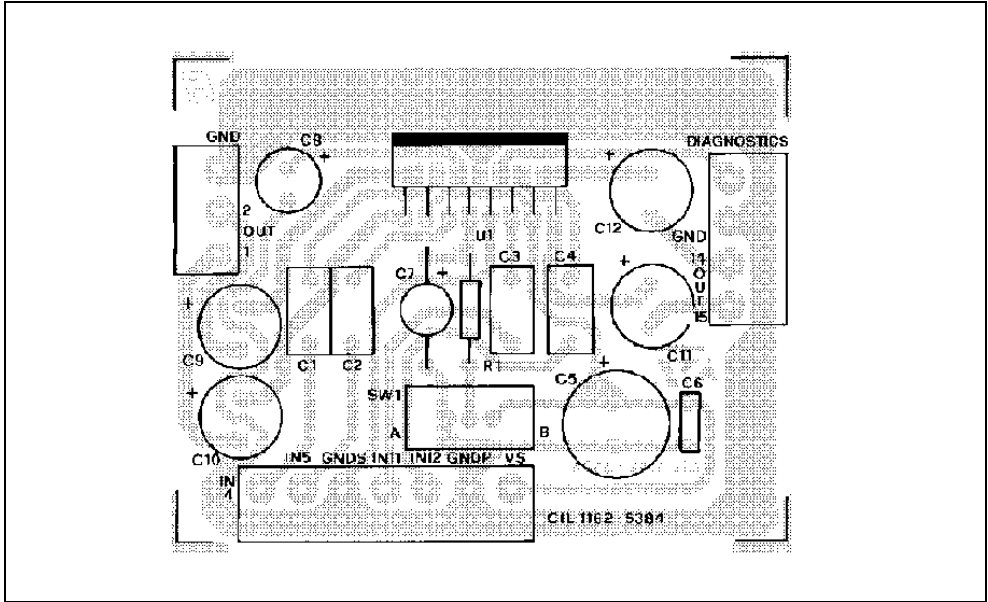

Figure 8. P.C. Board and Component Layout of the fig.5

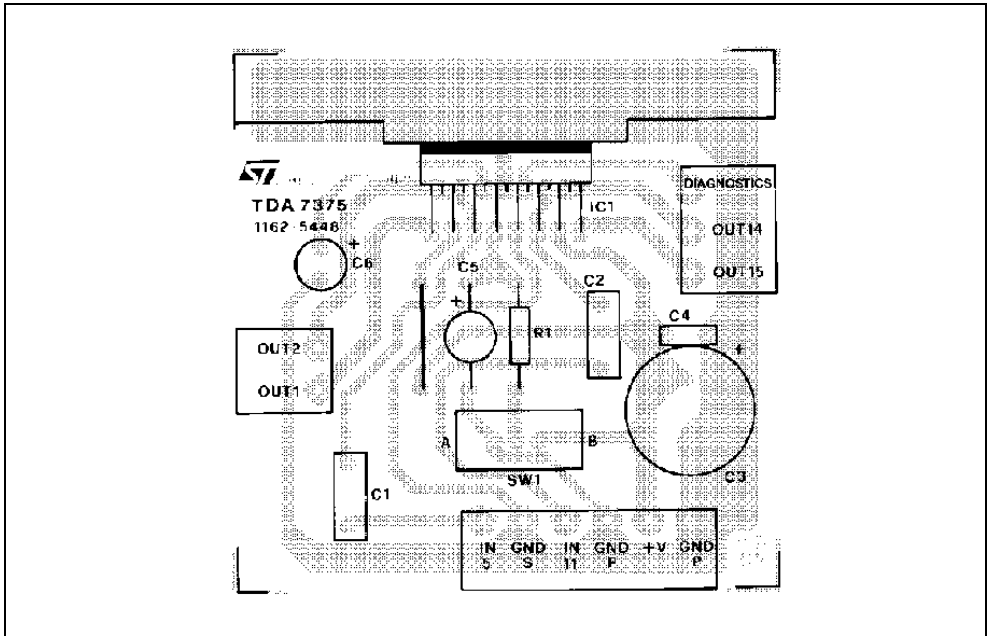

Figure 9. Quiescent Drain Current vs. Supply Voltage (Single Ended and Bridge).

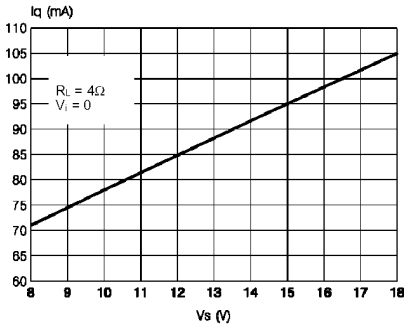

Figure 12. Output Power vs. Supply Voltage

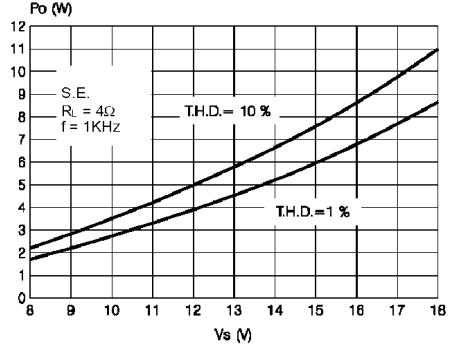

Figure 10. Quiescent Output Voltage vs. Supply Voltage (Single Ended and Bridge).

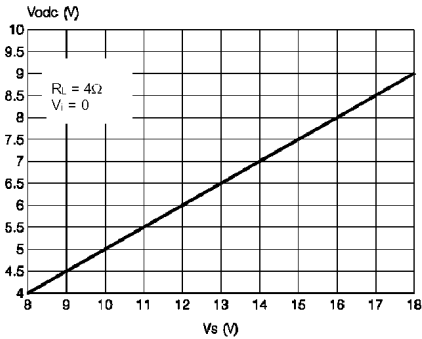

Figure 13. Output Power vs. Supply Voltage

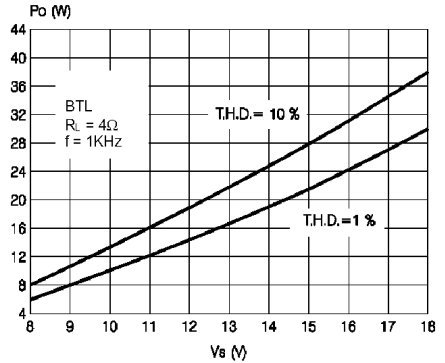

Figure 11. Output Power vs. Supply Voltage

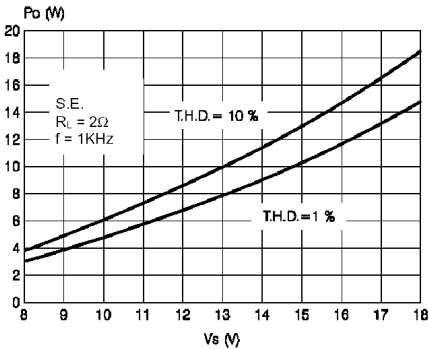

Figure 14. Distortion vs. Output Power

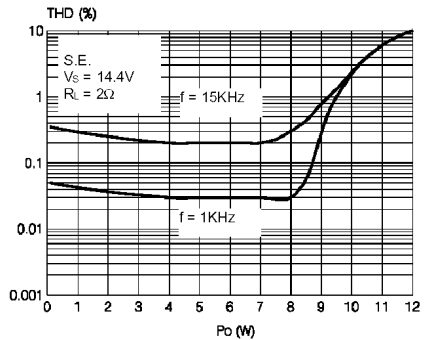

Figure 15. Distortion vs. Output Power

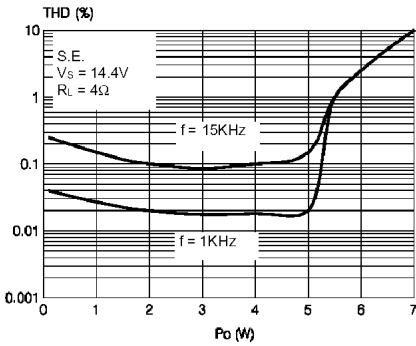

Figure 18. Supply Voltage Rejection vs. Frequency

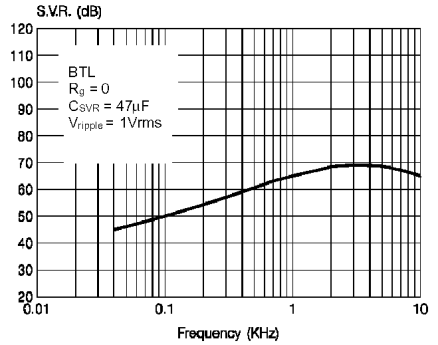

Figure 16. Distortion vs. Output Power

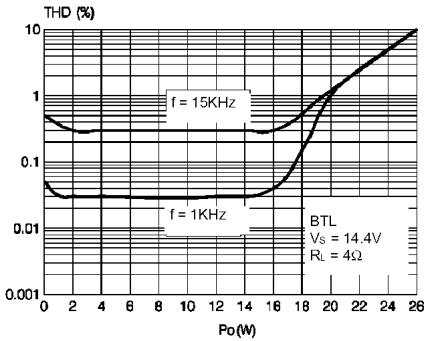

Figure 19. Supply Voltage Rejection vs. Frequency

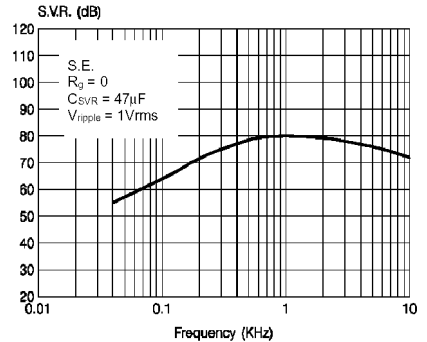

Figure 17. Cross-talk vs. Frequency

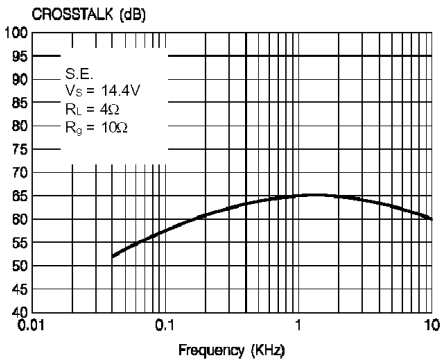

Figure 20. Stand-by Attenuation vs. Threshold Voltage

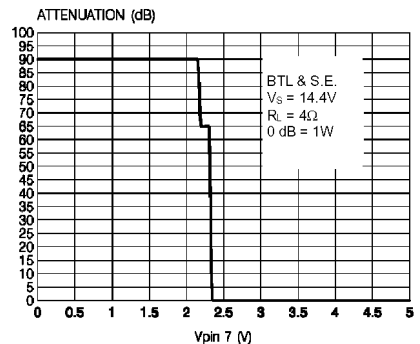

Figure 21. Total Power Dissipation and Efficiency vs. Output Power

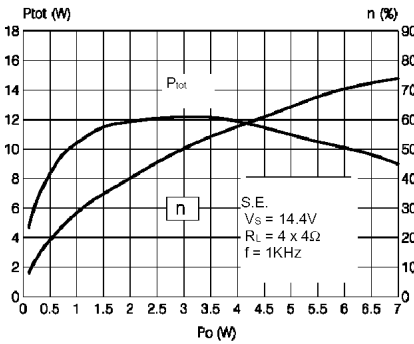
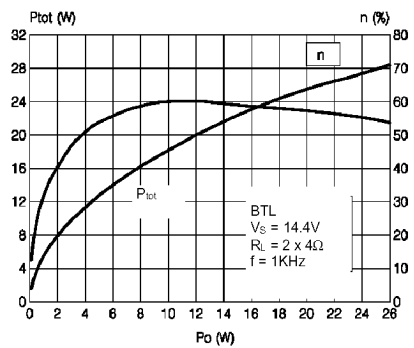

Figure 22. Total Power Dissipation and Efficiency vs. Output Power



5 GENERAL STRUCTURE

5.1 High Application Flexibility

The availability of 4 independent channels makes it possible to accomplish several kinds of applications ranging from 4 speakers stereo (F/R) to 2 speakers bridge solutions.

In case of working in single ended conditions the polarity of the speakers driven by the inverting amplifier must be reversed respect to those driven by non inverting channels. This is to avoid phase inconveniences causing sound alterations especially during the reproduction of low frequencies.

5.2 Easy Single Ended to Bridge Transition

The change from single ended to bridge configurations is made simply by means of a short circuit across the inputs, that is no need of further external components.

5.3 Gain Internally Fixed to 20dB in Single Ended, 26dB in Bridge

Advantages of this design choice are in terms of:

- components and space saving
- output noise, supply voltage rejection and distortion optimization.

5.4 Silent Turn On/Off and Muting/Stand-by Function

The stand-by can be easily activated by means of a CMOS level applied to pin 7 through a RC filter.

Under stand-by condition the device is turned off completely (supply current = $1\mu A$ typ.; output attenuation = 80dB min.). Every ON/OFF operation is virtually pop free. Furthermore, at turn-on the device stays in muting condition for a time determined by the value assigned to the SVR capacitor.

While in muting the device outputs become insensitive to any kinds of signal that may be present at the input terminals. In other words every transient coming from previous stages produces no unpleasant acoustic effect to the speakers.

5.5 STAND-BY DRIVING (pin 7)

Some precautions have to be taken in the definition of stand-by driving networks: pin 7 cannot be directly

driven by a voltage source whose current capability is higher than 5mA. In practical cases a series resistance has always to be inserted, having it the double purpose of limiting the current at pin 7 and to smooth down the stand-by ON/OFF transitions - in combination with a capacitor - for output pop prevention.

In any case, a capacitor of at least 100nF from pin 7 to S-GND, with no resistance in between, is necessary to ensure correct turn-on.

5.6 OUTPUT STAGE

The fully complementary output stage was made possible by the development of a new component: the ST exclusive power ICV PNP.

A novel design based upon the connection shown in fig. 23 has then allowed the full exploitation of its possibilities. The clear advantages this new approach has over classical output stages are as follows:

5.6.1 Rail-to-Rail Output Voltage Swing With No Need of Bootstrap Capacitors.

The output swing is limited only by the V_{CEsat} of the output transistors, which is in the range of 0.3Ω (R_{sat}) each. Classical solutions adopting composite PNP-NPN for the upper output stage have higher saturation loss on the top side of the waveform.

This unbalanced saturation causes a significant power reduction. The only way to recover power consists of the addition of expensive bootstrap capacitors.

5.6.2 Absolute Stability Without Any External Compensation.

Referring to the circuit of fig. 23 the gain V_{out}/V_{in} is greater than unity, approximately $1+R2/R1$. The DC output ($V_{CC}/2$) is fixed by an auxiliary amplifier common to all the channels.

By controlling the amount of this local feedback it is possible to force the loop gain ($A*\beta$) to less than unity at frequency for which the phase shift is 180° . This means that the output buffer is intrinsically stable and not prone to oscillation.

Most remarkably, the above feature has been achieved in spite of the very low closed loop gain of the amplifier. In contrast, with the classical PNP-NPN stage, the solution adopted for reducing the gain at high frequencies makes use of external RC networks, namely the Boucherot cells.

5.7 BUILT-IN SHORTCIRCUIT PROTECTION

Figure 23. The New Output Stage

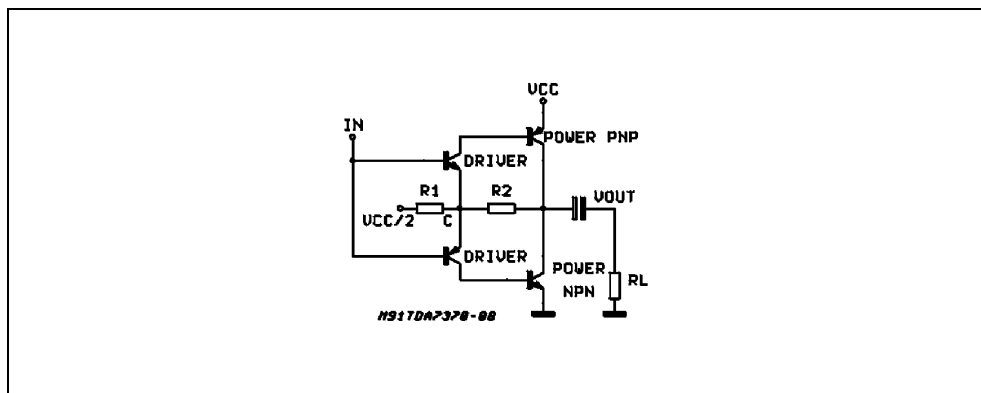

Reliable and safe operation, in presence of all kinds of short circuit involving the outputs is assured by BUILT-IN protectors. Additionally to the AC/DC short circuit to GND, to V_S , across the speaker, a SOFT SHORT condition is signalled out during the TURN-ON PHASE so assuring correct operation for the de-

vice itself and for the loudspeaker.

This particular kind of protection acts in a way to avoid that the device is turned on (by ST-BY) when a resistive path (less than 16 ohms) is present between the output and GND. As the involved circuitry is normally disabled when a current higher than 5mA is flowing into the ST-BY pin, it is important, in order not to disable it, to have the external current source driving the ST-BY pin limited to 5mA.

This extra function becomes particularly attractive when, in the single ended configuration, one capacitor is shared between two outputs (see fig. 24). Supposing that the output capacitor Cout for any reason is shorted, the loudspeaker will not be damaged being this soft short circuit condition revealed.

Figure 24. Single ended configuration circuit

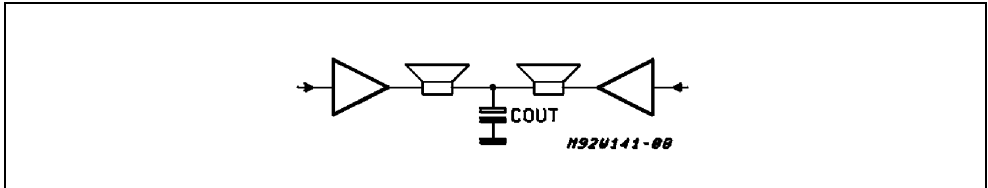

5.7.1 Diagnostics Facility

The TDA7375 is equipped with a diagnostic circuitry able to detect the following events:

- Clipping in the output signal
- Thermal shutdown
- Output fault:
 - short to GND
 - short to VS
 - soft short at turn on

The information is available across an open collector output (pin 10) through a current sinking when the event is detected. A current sinking at pin 10 is triggered when a certain distortion level is reached at any of the outputs. This function allows gain compression possibility whenever the amplifier is overdriven.

5.7.2 Thermal Shutdown

In this case the output 10 will signal the proximity of the junction temperature to the shutdown threshold. Typically current sinking at pin 10 will start ~10°C before the shutdown threshold is reached.

Figure 25. Clipping Detection Waveforms

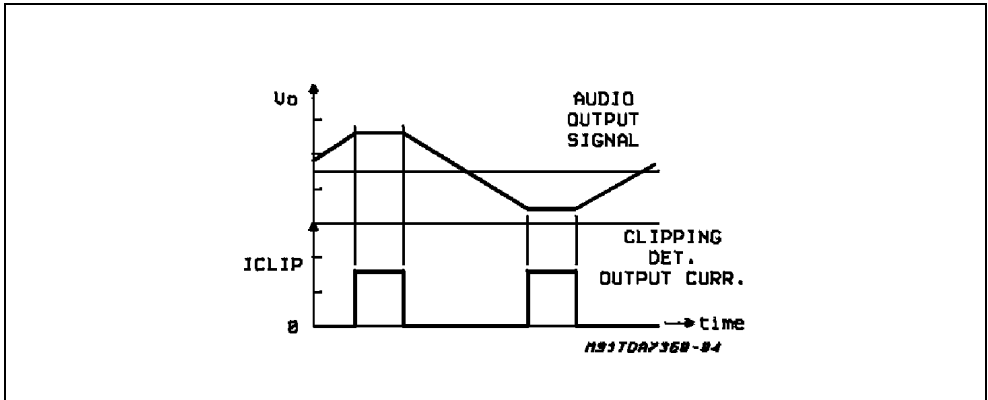

Figure 26. Output Fault Waveforms (see fig. 27)

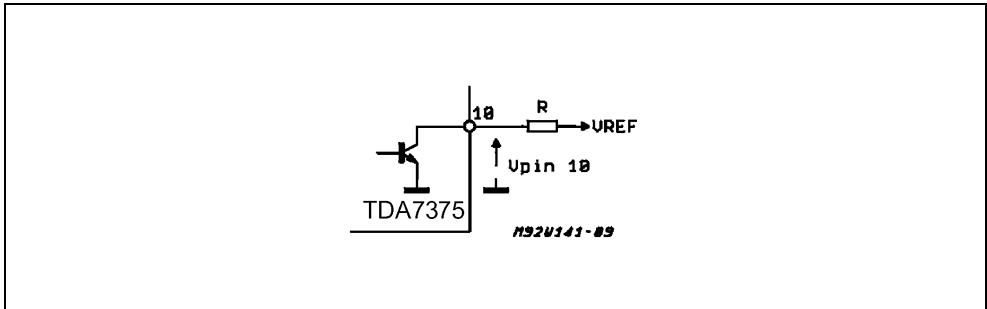
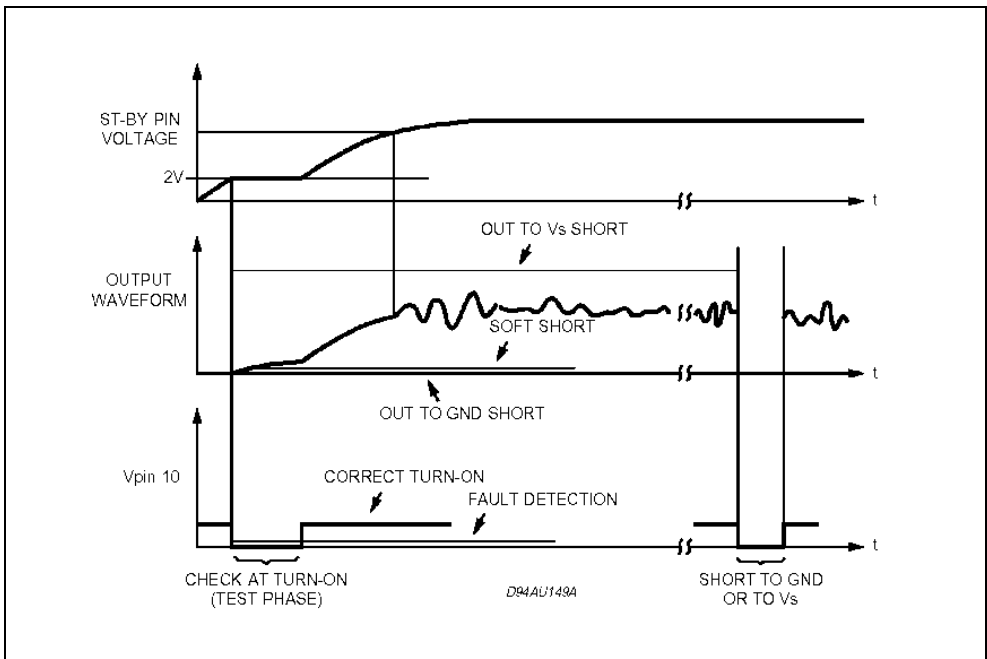

Figure 27. Fault Waveforms



5.8 HANDLING OF THE DIAGNOSTICS INFORMATION

As various kinds of information is available at the same pin (clipping detection, output fault, thermal proximity), this signal must be handled properly in order to discriminate each event.

This could be done by taking into account the different timing of the diagnostic output during each case.

Normally the clip detector signalling produces a low level at pin 10 that is shorter than that present under faulty conditions; based on this assumption an interface circuitry to differentiate the information is represented in the schematic of fig. 29.

Figure 28. Waveforms

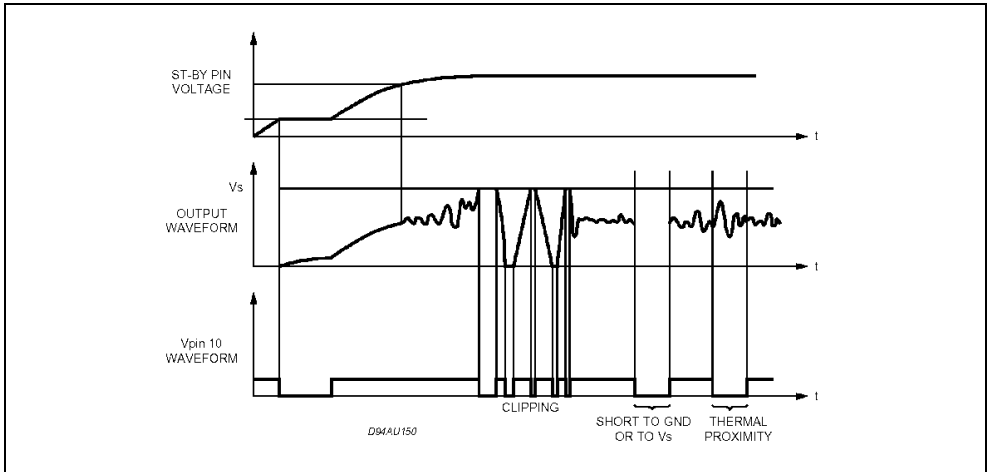
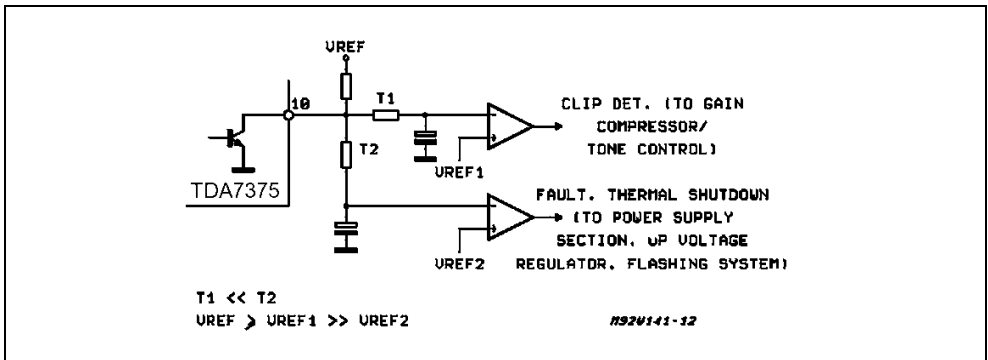

Figure 29. Interface circuitry to differentiate the information schematic



5.9 PCB-LAYOUT GROUNDING (general rules)

The device has 2 distinct ground leads, P-GND (POWER GROUND) and S-GND (SIGNAL GROUND) which are practically disconnected from each other at chip level. Proper operation requires that P-GND and S-GND leads be connected together on the PCB-layout by means of reasonably low-resistance tracks.

As for the PCB-ground configuration, a star-like arrangement whose center is represented by the supply-filtering electrolytic capacitor ground is highly advisable. In such context, at least 2 separate paths have to be provided, one for P-GND and one for S-GND. The correct ground assignments are as follows:

STANDBY CAPACITOR, pin 7 (or any other standby driving networks): on S-GND

SVR CAPACITOR (pin 6): on S-GND and to be placed as close as possible to the device.

INPUT SIGNAL GROUND (from active/passive signal processor stages): on S-GND.

SUPPLY FILTERING CAPACITORS (pins 3,13): on P-GND.

The (-) terminal of the electrolytic capacitor has to be directly tied to the battery (-) line and this should represent the starting point for all the ground paths.

6 PACKAGE INFORMATION

In order to meet environmental requirements, ST (also) offers these devices in ECOPACK® packages. ECOPACK® packages are lead-free. The category of second Level Interconnect is marked on the package and on the inner box label, in compliance with JEDEC Standard JESD97. The maximum ratings related to soldering conditions are also marked on the inner box label.

ECOPACK is an ST trademark. ECOPACK specifications are available at: www.st.com.

Figure 30. Multiwatt 15 Mechanical Data & Package Dimensions

DIM.	mm			inch		
	MIN.	TYP.	MAX.	MIN.	TYP.	MAX.
A5						0.197
B			2.65			0.104
C			1.6			0.063
D		1			0.039	
E	0.49		0.55	0.019		0.022
F	0.66		0.75	0.026		0.030
G	1.02	1.27	1.52	0.040	0.050	0.060
G1	17.53	17.78	18.03	0.690	0.700	0.710
H1	19.6				0.772	
H2			20.2			0.795
L	21.9	22.2	22.5	0.862	0.874	0.886
L1	21.7	22.1	22.5	0.854	0.87	0.886
L2	17.65		18.1	0.695		0.713
L3	17.25	17.5	17.75	0.679	0.689	0.699
L4	10.3	10.7	10.9	0.406	0.421	0.429
L7	2.65		2.9	0.104		0.114
M	4.25	4.55	4.85	0.167	0.179	0.191
M1	4.73	5.08	5.43	0.186	0.200	0.214
S	1.9		2.6	0.075		0.102
S1	1.9		2.6	0.075		0.102
Dia1	3.65		3.85	0.144		0.152

OUTLINE AND MECHANICAL DATA

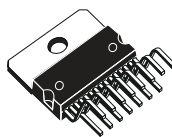

Multiwatt15 (Vertical)

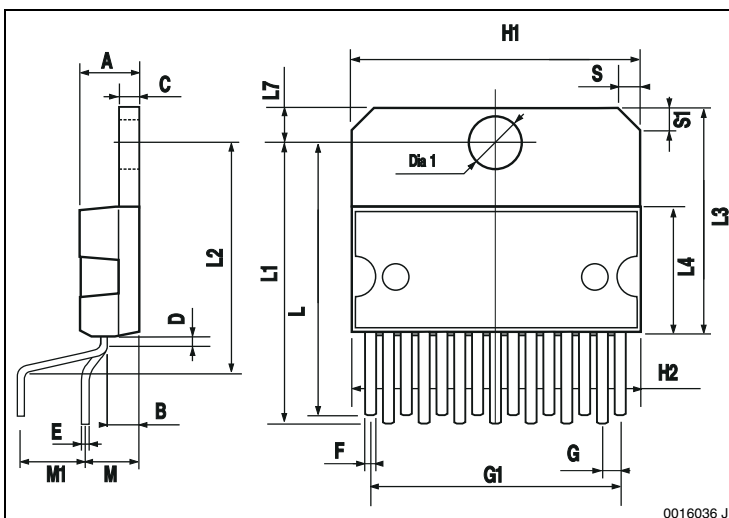

7 REVISION HISTORY

Table 5. Revision History

Date	Revision	Description of Changes
July 2004	2	First Issue in EDOCS
March 2005	3	Changed the Style-sheet in compliance to the new "Corporate Technical Publications Design Guide". Deleted package Multiwatt15 Horizontal.
01-Jul-2008	4	Updated the root part number in the title of the cover page. Added Ecopack information in "PACKAGE INFORMATION" section.
20-Sep-2013	5	Updated Disclaimer.

Please Read Carefully:

Information in this document is provided solely in connection with ST products. STMicroelectronics NV and its subsidiaries ("ST") reserve the right to make changes, corrections, modifications or improvements, to this document, and the products and services described herein at any time, without notice.

All ST products are sold pursuant to ST's terms and conditions of sale.

Purchasers are solely responsible for the choice, selection and use of the ST products and services described herein, and ST assumes no liability whatsoever relating to the choice, selection or use of the ST products and services described herein.

No license, express or implied, by estoppel or otherwise, to any intellectual property rights is granted under this document. If any part of this document refers to any third party products or services it shall not be deemed a license grant by ST for the use of such third party products or services, or any intellectual property contained therein or considered as a warranty covering the use in any manner whatsoever of such third party products or services or any intellectual property contained therein.

UNLESS OTHERWISE SET FORTH IN ST'S TERMS AND CONDITIONS OF SALE ST DISCLAIMS ANY EXPRESS OR IMPLIED WARRANTY WITH RESPECT TO THE USE AND/OR SALE OF ST PRODUCTS INCLUDING WITHOUT LIMITATION IMPLIED WARRANTIES OF MERCHANTABILITY, FITNESS FOR A PARTICULAR PURPOSE (AND THEIR EQUIVALENTS UNDER THE LAWS OF ANY JURISDICTION), OR INFRINGEMENT OF ANY PATENT, COPYRIGHT OR OTHER INTELLECTUAL PROPERTY RIGHT.

ST PRODUCTS ARE NOT DESIGNED OR AUTHORIZED FOR USE IN: (A) SAFETY CRITICAL APPLICATIONS SUCH AS LIFE SUPPORTING, ACTIVE IMPLANTED DEVICES OR SYSTEMS WITH PRODUCT FUNCTIONAL SAFETY REQUIREMENTS; (B) AERONAUTIC APPLICATIONS; (C) AUTOMOTIVE APPLICATIONS OR ENVIRONMENTS, AND/OR (D) AEROSPACE APPLICATIONS OR ENVIRONMENTS. WHERE ST PRODUCTS ARE NOT DESIGNED FOR SUCH USE, THE PURCHASER SHALL USE PRODUCTS AT PURCHASER'S SOLE RISK, EVEN IF ST HAS BEEN INFORMED IN WRITING OF SUCH USAGE, UNLESS A PRODUCT IS EXPRESSLY DESIGNATED BY ST AS BEING INTENDED FOR "AUTOMOTIVE, AUTOMOTIVE SAFETY OR MEDICAL" INDUSTRY DOMAINS ACCORDING TO ST PRODUCT DESIGN SPECIFICATIONS. PRODUCTS FORMALLY ESCC, QML OR JAN QUALIFIED ARE DEEMED SUITABLE FOR USE IN AEROSPACE BY THE CORRESPONDING GOVERNMENTAL AGENCY.

Resale of ST products with provisions different from the statements and/or technical features set forth in this document shall immediately void any warranty granted by ST for the ST product or service described herein and shall not create or extend in any manner whatsoever, any liability of ST.

ST and the ST logo are trademarks or registered trademarks of ST in various countries.

Information in this document supersedes and replaces all information previously supplied.

The ST logo is a registered trademark of STMicroelectronics. All other names are the property of their respective owners.

© 2013 STMicroelectronics - All rights reserved

STMicroelectronics group of companies

Australia - Belgium - Brazil - Canada - China - Czech Republic - Finland - France - Germany - Hong Kong - India - Israel - Italy - Japan - Malaysia - Malta - Morocco - Philippines - Singapore - Spain - Sweden - Switzerland - United Kingdom - United States of America

www.st.com