

FEATURES

- Low Power Modem Telephony Codec
- 16-Bit Oversampling Σ - Δ Converter Technology
- Intel AC'97 Rev 2.1-Compliant Modem Codec Implementation
- AC'97 or DSP Style Serial Interface
- Supports All Modem/Fax Standards Including V.90
- Multiple Crystal/Clock Rates Supported
- Programmable Gain, Attenuation and Mute
- On-Chip Signal Filters
- Digital Interpolation and Decimation Filters
- Analog Output Low Pass
- Programmable Sample Rates
- From 6.4 kHz to 16 kHz
- With 1 Hz, 8/7 Hz and 10/7 Hz Resolution

- Digital Codec Engine with Variable Sample Rate Conversion

- Digital Monitor Speaker Output

- 24-Lead TSSOP Package

- 0.6 μ m CMOS Technology

- Operation from 3.3 V or 5 V Supply

- Advanced Power Management

APPLICATIONS

- Modems (PC and Embedded)

- Voice and Telephony

- Fax Machines, Answering Machines, Speakerphones

- PBX Systems

- Smart Appliances

REFERENCE DESIGN

- Available

FUNCTIONAL BLOCK DIAGRAM

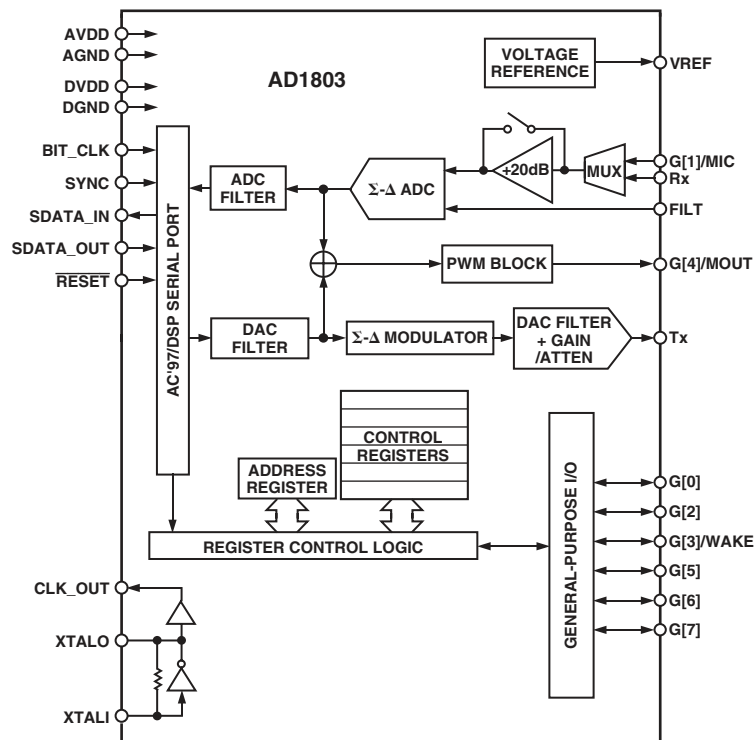

REV. 0

Information furnished by Analog Devices is believed to be accurate and reliable. However, no responsibility is assumed by Analog Devices for its use, nor for any infringements of patents or other rights of third parties that may result from its use. No license is granted by implication or otherwise under any patent or patent rights of Analog Devices.

AD1803—SPECIFICATIONS

STANDARD TEST CONDITIONS UNLESS OTHERWISE NOTED

Temperature	25°C	<i>DAC Output Test Conditions</i>
Digital Supply	3.3 V/5 V	0 dB Attenuation Relative to Full-Scale
Analog Supply	3.3 V/5 V	Input 0 dB
Sample Rate (f_s)	8 kHz	Mute Off
Input Signal	1008 Hz	10 k Ω Output Load
Analog Output Pass Band	20 Hz to 4 kHz	<i>ADC Input Test Conditions</i>
ADC FFT Size	512	Autocalibrated
DAC FFT Size	4096	0 dB PGA Gain
V_{IH}	2.1 V	Mute Off
V_{IL}	1.2 V	Input -1.0 dB Relative to Full-Scale
V_{OH}	2.9 V	
V_{OL}	0.3 V	
I_{OH}	-2.0 mA	
I_{OL}	+2.0 mA	

ADC RECEIVE PATH

	Min	Typ	Max	Unit
Full-Scale Input Voltage (RMS Values Assume Sine Wave Input, PGA Gain = 0 dB, Offset Error = 0% of FS)		1.56		V rms
AD1803 Rx Input (0 dBm)	2.1	2.2	2.3	V p-p
Resistance—Rx Input*				
with 0 dB Gain		110		k Ω
with +20 dB Gain		10		k Ω
Capacitance—Rx Input*		15		pF
Rx Programmable Gain				
Gain Step Size (0 dB to 42.5 dB, All Steps Tested)	1.0	1.5	2.0	dB
Input Gain Span (Note: The ADC Gain is achieved using a 0 dB to 22.5 dB Variable Gain Stage and a 20 dB Fixed Gain Stage. The 22.5 dB to 42.5 dB Gain Steps are achieved by enabling the 20 dB Gain Stage.)	41.5	42.5	43.5	dB
Analog-to-Digital Converter				
Dynamic Range (-60 dB Input, THD+N Referenced to Full-Scale, PGA Gain = 0 dB)	85	90		dB
Dynamic Range (-60 dB Input, THD+N Referenced to Full-Scale, PGA Gain = 6 dB)*		90		dB
Dynamic Range (-60 dB Input, THD+N Referenced to Full-Scale, PGA Gain = +12 dB)*		90		dB
THD+N (-1 dB Input Referenced to Full-Scale)		-90	-85	dB
Signal-to-Intermodulation Distortion (CCIF Method)*		80		dB
Offset Error (0 V Analog Input, PGA Gain = 0 dB)		1	5	% of FS

*Guaranteed, not tested.

Specifications subject to change without notice.

DAC TRANSMIT PATH

	Min	Typ	Max	Unit
Digital-to-Analog Converter				
Dynamic Range (-60 dB Input, THD+N Referenced to Full-Scale, Output Gain = 0 dB)		85		dB
THD+N (-1 dB Input Referenced to Full-Scale)		-75		dB
Signal-to-Intermodulation Distortion (CCIF Method)*		80		dB
Total Out-of-Band Energy (Measured from $0.555 \times f_s$ to 100 kHz)*			-40	dB
DC Offset		100		mV
Programmable Gain/Attenuator				
Step Size (+12 dB to -34.5 dB, All Steps Tested)	1.0	1.5	2.0	dB
Output Attenuation Span	45.5	46.5	48	dB
Full-Scale Output Voltage				
AD1803 Tx Output (0 dBm)	2.1	2.2	2.3	V p-p
Pin Capacitance—AD1803 Tx		15		pF
Load Capacitance—AD1803 Tx		100		pF

*Guaranteed, not tested.

Specifications subject to change without notice.

MONITOR OUTPUT

	Min	Typ	Max	Unit
Digital-to-Analog Converter				
Dynamic Range (–60 dB Input, THD+N Referenced to Full-Scale, A-Weighted)*		50		dB
THD+N (Referenced to Full-Scale)*		0.316	1	%
		–50	–40	dB
Programmable Gain/Attenuator				
Step Size (–18 dB to +45 dB)*	2.4	3.0	3.6	dB
Output Attenuation Span*		63		dB

NOTES

*Guaranteed, not tested.

Specifications subject to change without notice.

The table above assumes the G[4]/MOUT pin is loaded with a 1 k Ω resistor in series with a parallel 4.7 k Ω resistor and 100 nF capacitor combination tied to digital ground. This filter, with the output taken from the middle node, has a 1500 Hz corner to filter out high-frequency Σ - Δ noise, and generates an approximate 1 V p-p output when using a 5 V digital supply with the monitor output configured as first order (Bits MDM[1:0] set to 10 in Register 0 \times 60 Bank 2) if the filter output load is greater than or equal to 20 k Ω .

DIGITAL DECIMATION AND INTERPOLATION FILTERS¹

	Min	Typ	Max	Unit
Pass-Band Edge (–0.22 dB Point)			$0.445 \times f_s$	Hz
Pass-Band (–3.0 dB Point)			$0.490 \times f_s$	Hz
Pass-Band Ripple	0.0		–0.2	dB
Transition Band	$0.445 \times f_s$		$0.555 \times f_s$	Hz
Stop-Band Edge ²	$0.555 \times f_s$			Hz
Stop-Band Rejection (Plus 3 dB Roll-Off)	78.0			dB
Group Delay			$21/f_s$	s
Group Delay Variation Over Pass Band				
0 kHz to 4 kHz			0.45	μ s
0 kHz to 8 kHz			1.30	μ s
Sample Rate	6.4		16	kHz

NOTES

¹Guaranteed, not tested.²The stop band repeats itself at multiples of $64 \times f_s$, where f_s is the sampling frequency. Thus the digital filter will attenuate to –78.0 dB or better across the frequency spectrum except for a range $\pm 0.555 \times f_s$ wide at multiples of $64 \times f_s$.

Specifications subject to change without notice.

TYPICAL SUPPLY CURRENT (For Most Common Modes of Operation)

Resource	3.3 V	5.0 V	Register Writes To Enter Mode	Assumption
GPIO Weak Pull-Up Current per Pin	~100	~140 μ A	Default Settings After Power-On $\overline{\text{RESET}}$	
While $\overline{\text{RESET}}$ Is Asserted:				
XTAL Off (All Down)	<30.0	<40.0 μ A	Default Settings After Power-On $\overline{\text{RESET}}$	a
XTALI Enabled: Nominal Power	1.4	2.4 mA	5C:R34P4 = 1	
XTALI Enabled: Low Power	1.0	1.7	5C:R34P4 = 1, 64b1:XTLP = 1	
and CLKOUT Pin Running	1.6	3.2	and 5C:CLKEA = 1	b
While $\overline{\text{RESET}}$ Is Deasserted and Analog and Digital Codec in Full Power Mode				
SPORT and CLKOUT Active	2.6	6.4	Default Settings After Power-On $\overline{\text{RESET}}$	b, c
and XTAL in Low Power Mode	2.2	5.7	and 64b1:XTLP = 1	b, c
and CLKOUT Inactive (Low)	1.7	4.3	and 5C:CLKED = 0	c
and VREF Powered Up	1.9	4.5	and 3E:VPDN = 0	c
and ADC Enabled	7.3	12.4	and 3E:APDN = 0	c
or				
and DAC Enabled	8.2	13.7	and 3E:DPDN = 0	c, f
or				
and ADC + DAC Enabled	9.2	14.7	and 3E:APDN = DPDN = 0	c, f
or				
and ADC, DAC, + MON Enabled	9.3	14.9	and 3E:APDN = DPDN = 0, 5E : GPMON = 1	c, d, f
or				
and ADC, DAC, + MON Enabled	10.2	16.3	and 3E:APDN = DPDN = 0, 5E : GPMON = 1	c, e, f

AD1803

ASSUMPTIONS

- a Assumes all inputs are static (not switching) and all output loads are capacitive (nonresistive).
- b Excludes current drawn by CLKOUT pin board loading.
- c Assumes the serial interface is configured in AC'97 primary mode with 20 pF loads on pins SDATA_IN and BIT_CLK. Typical current will be approximately 0.8 mA less if the serial interface is configured in DSP mode with 20 pF loads on pins SYNC, BIT_CLK, and SDATA_IN (due to a lower BIT_CLK frequency).
- d Assumes a 20 pF load on Pin G[4]/MOUT.
- e Assumes the G[4]/MOUT pin is loaded with a 1 kΩ resistor in series with a parallel 4.7 kΩ resistor and 100 nF capacitor combination tied to digital ground. This filter, with the output taken from the middle node, has a 1500 Hz corner to filter out high-frequency Σ-Δ noise, and generates an approximate 1 V p-p output when using a 5 V digital supply with the Monitor output configured as first order (Bits MDM[1:0] set to 10 in Register 0 × 60 Bank 2) if the filter output load is greater than or equal to 20 kΩ.
- f Assumes no DAC load. 0.6 mA should be added if a 600 Ω load is used.
- g All currents in mA unless otherwise noted.

Specifications subject to change without notice.

STATIC DIGITAL SPECIFICATIONS

	Min	Typ	Max	Unit
High Level Input Voltage (V_{IH}): Digital Inputs	0.65 × DVDD			V
Low Level Input Voltage (V_{IL})	0.35 × DVDD			V
High Level Output Voltage (V_{OH}), $I_{OH} = -0.5$ mA	0.9 × DVDD			V
Low Level Output Voltage (V_{OL}), $I_{OL} = +0.5$ mA	0.1 × DVDD			V
Input Leakage Current	-10		+10	μA
Output Leakage Current	-10		+10	μA

Specifications subject to change without notice.

POWER SUPPLY

	Min	Typ	Max	Unit
Power Supply Range—Analog (3.3 V/5 V) AVDD	3.0/4.75			V
Power Supply Range—Digital (3.3 V/5 V) DVDD	3.0/4.75			V
Analog and Digital Supply Current—5 V		*		
Analog and Digital Supply Current—3.3 V		*		
Power Supply Rejection (100 mV p-p Signal @ 1 kHz) (At Both Analog and Digital Supply Pins, Both ADCs and DACs)		40		dB

NOTES

*Refer to table on typical supply current.

Specifications subject to change without notice.

CLOCK SPECIFICATIONS

	Min	Typ	Max	Unit
Input Clock Frequency	12.288	24.576	32.768	MHz
Recommended Clock Duty Cycle	45	50	55	%

Specifications subject to change without notice.

TIMING PARAMETERS (Guaranteed Over Operating Temperature Range and Supply Power)

Parameter	Symbol	Min	Typ	Max	Unit
Serial Port—AC'97 Mode					
$\overline{\text{RESET}}$ Active Low Pulsewidth	t _{RST_LOW}	1.0			μs
$\overline{\text{RESET}}$ Inactive to BIT_CLK Start-Up Delay	t _{RST2CLK}	162.8			ns
SYNC Active High Pulsewidth (Warm $\overline{\text{RESET}}$)	t _{SYNC_HIGH}		1.3		μs
SYNC Inactive to BIT_CLK Start-Up Delay (Warm $\overline{\text{RESET}}$)	t _{SYNC2CLK}	162.8			ns
BIT_CLK Frequency			12.288		MHz
BIT_CLK Period	t _{CLK_PERIOD}		81.4		ns
BIT_CLK Output Jitter*				750	ps
BIT_CLK High Pulsewidth	t _{CLK_HIGH}	36.62	40.69	44.76	ns
BIT_CLK Low Pulsewidth	t _{CLK_LOW}	36.62	40.69	44.76	ns
SYNC Frequency			48.0		kHz
SYNC Period	t _{SYNC_PERIOD}		20.8		μs
Setup to Falling Edge of BIT_CLK	t _{SETUP}	10.0			ns
Hold from Falling Edge of BIT_CLK	t _{HOLD}	10.0			ns
Propagation Delay	t _{CO}			15	ns
BIT_CLK Rise Time	t _{RISECLK}	2	4	6	ns
BIT_CLK Fall Time	t _{FALLCLK}	2	4	6	ns
SYNC Rise Time	t _{RISESYNC}	2	4	6	ns
SYNC Fall Time	t _{FALLSYNC}	2	4	6	ns
SDATA_IN Rise Time	t _{RISEDIN}	2	4	6	ns
SDATA_IN Fall Time	t _{FALLDIN}	2	4	6	ns
SDATA_OUT Rise Time	t _{RISEDOUT}	2	4	6	ns
SDATA_OUT Fall Time	t _{FALLOUT}	2	4	6	ns
End of Slot 2 to BIT_CLK, SDATA_IN Low (MLNK Set)	t _{S2_PDOWN}	2		1000	ns
Setup to Trailing Edge of $\overline{\text{RESET}}$ (Applies to SYNC, SDATA_OUT)	t _{SETUP2RST}	15			ns
Rising Edge of $\overline{\text{RESET}}$ to HI-Z Delay (ATE Test Mode)	t _{OFF}			25	ns

Parameter	Symbol	Min	Typ	Max	Unit
Serial Port—DSP Mode					
$\overline{\text{RESET}}$ Active Low Pulsewidth	t _{RST_LOW}	1.0			μs
$\overline{\text{RESET}}$ Inactive to BIT_CLK Start-Up Delay	t _{RST2CLK}	162.8			ns
BIT_CLK Frequency			4.096		MHz
BIT_CLK Period	t _{CLK_PERIOD}		244.14		ns
BIT_CLK Output Jitter*				750	ps
SYNC Frequency			8		kHz
SYNC Period	t _{SYNC_PERIOD}		125		μs
Setup to Falling Edge of BIT_CLK	t _{SETUP}	10.0			ns
Hold from Falling Edge of BIT_CLK	t _{HOLD}	10.0			ns
Propagation Delay	t _{CO}			15	ns
BIT_CLK Rise Time	t _{RISECLK}	2	4	6	ns
BIT_CLK Fall Time	t _{FALLCLK}	2	4	6	ns
SYNC Rise Time	t _{RISESYNC}	2	4	6	ns
SYNC Fall Time	t _{FALLSYNC}	2	4	6	ns
SDATA_IN Rise Time	t _{RISEDIN}	2	4	6	ns
SDATA_IN Fall Time	t _{FALLDIN}	2	4	6	ns
SDATA_OUT Rise Time	t _{RISEDOUT}	2	4	6	ns
SDATA_OUT Fall Time	t _{FALLOUT}	2	4	6	ns
Setup to Trailing Edge of $\overline{\text{RESET}}$ (Applies to SYNC, SDATA_OUT)	t _{SETUP2RST}	15			ns
Rising Edge of $\overline{\text{RESET}}$ to HI-Z Delay (ATE Test Mode)	t _{OFF}			25	ns

NOTES

*Output jitter is directly dependent on crystal input jitter.

Specifications subject to change without notice.

AD1803

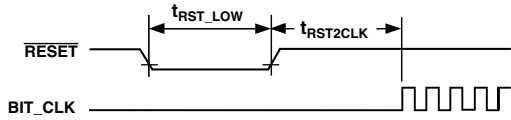

Figure 1. Cold $\overline{\text{RESET}}$

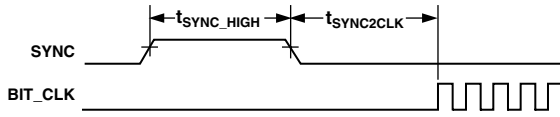

Figure 2. Warm $\overline{\text{RESET}}$

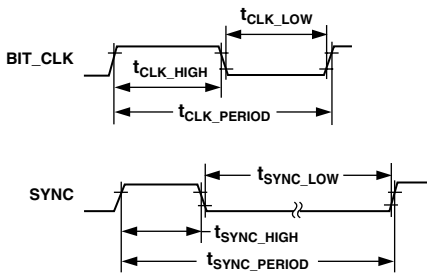

Figure 3. Clock Timing

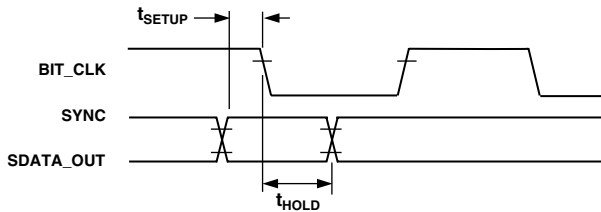

Figure 4. Data Setup and Hold

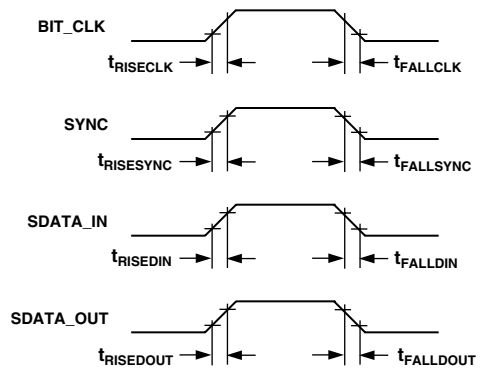

Figure 5. Signal Rise and Fall Time

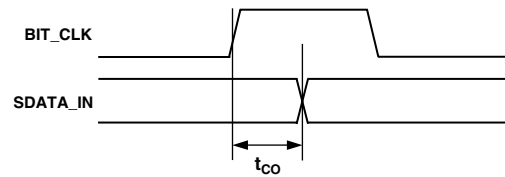

Figure 6. Propagation Delay

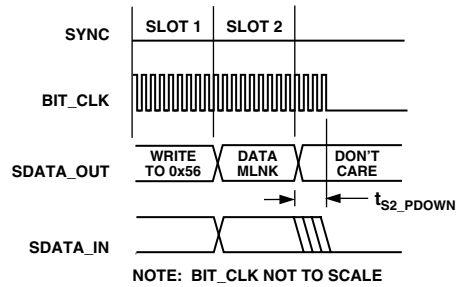

Figure 7. AC Link Low Power Mode Timing

ABSOLUTE MAXIMUM RATINGS*

	Min	Max	Unit
Power Supplies			
Digital (DVDD)	-0.3	+6.0	V
Analog (AVDD)	-0.3	+6.0	V
Input Current (Except Supply Pins)		±10.0	mA
Analog Input Voltage (Signal Pins)	-0.3	AVDD + 0.3	V
Digital Input Voltage (Signal Pins)	-0.3	DVDD + 0.3	V
Ambient Temperature (Operating)	0	70	°C
Storage Temperature	-65	+150	°C

*Stresses greater than those listed under Absolute Maximum Ratings may cause permanent damage to the device. This is a stress rating only; functional operation of the device at these or any other conditions above those indicated in the operational section of this specification is not implied. Exposure to absolute maximum rating conditions for extended periods may affect device reliability.

ENVIRONMENTAL CONDITIONS

Ambient Temperature Rating

$$T_{AMB} = T_{CASE} - (P_D \times \theta_{CA})$$

T_{CASE} = Case Temperature in °C

P_D = Power Dissipation in W

θ_{CA} = Thermal Resistance (Case-to-Ambient)

θ_{JA} = Thermal Resistance (Junction-to-Ambient)

θ_{JC} = Thermal Resistance (Junction-to-Case)

PACKAGE CHARACTERISTICS

Package	θ_{JA}	θ_{JC}	θ_{CA}
TSSOP	83.8°C/W	15.6°C/W	68.2°C/W

ORDERING GUIDE

Model	Temperature Range	Package Description	Package Option
AD1803JRU	0°C to 70°C	24-Lead Thin Shrink Small Outline Package	RU-24

CAUTION

ESD (electrostatic discharge) sensitive device. Electrostatic charges as high as 4000 V readily accumulate on the human body and test equipment and can discharge without detection. Although the AD1803 features proprietary ESD protection circuitry, permanent damage may occur on devices subjected to high-energy electrostatic discharges. Therefore, proper ESD precautions are recommended to avoid performance degradation or loss of functionality.



PIN CONFIGURATION

24-Lead TSSOP (RU-24)

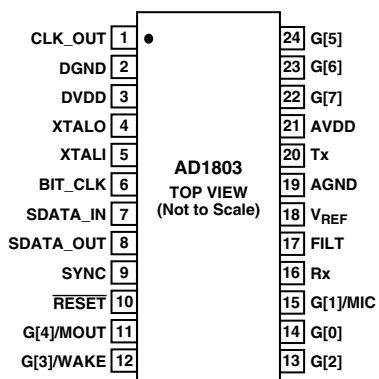

AD1803

PIN FUNCTION DESCRIPTIONS

Analog Signals

Pin Name	TSSOP	I/O	Description
DVDD	3	I	Digital Supply. Range: 5.0 V \pm 10% or 3.3 V \pm 10% (independent of AVDD).
DGND	2	I	Digital Ground. Must be at same potential as AGND.
AVDD	21	I	Analog Supply. Range: 5.5 V through 3.0 V (independent of DVDD).
AGND	19	I	Analog Ground. Must be at same potential as DGND.

Clock Signals

Pin Name	TSSOP	I/O	Description
XTALI	5	I	Crystal or Clock Input (12.288, 24.576, or 32.768 MHz). This clock input is necessary only if the AD1803 is configured in either AC'97 primary or DSP mode, or if a wake interrupt from an event is required (in any mode). This pin must be tied to DVDD or DGND (not floated) when clock input is not necessary. If a crystal is used, it must be parallel resonant first harmonic, and tied between this pin and the XTALO pin with load capacitance specified by the crystal supplier. See Bits XTAL[1:0] in Register 0x5C for further details.
XTALO	4	O	Crystal Output. This pin should be floated when a crystal is not used.
CLK_OUT	1	O	Buffered version of clock present on the XTALI pin, unless disabled. See Bits CLKED and CLKEA in Register 0x5C for further details.

Serial Interface Signals (See Pins G[3:2] for Serial Interface Mode Selection)

Pin Name	TSSOP	I/O	Description
$\overline{\text{RESET}}$	10	I	Active Low Power-Down. Level of power-down is determined by bits in Register 0x5C. This pin must be asserted (driven LOW) as power is first applied until the supply is stable. Contrary to the name of this pin, determined by Intel's AC'97 specification, the AD1803 is $\overline{\text{RESET}}$ exclusively by an internal power-on- $\overline{\text{RESET}}$ circuit.
BIT_CLK	6	I/O	Serial Data Clock: Output if the AD1803 configured in AC'97 Primary or DSP mode, Input if the AD1803 is configured in any AC'97 secondary mode.
SYNC	9	I/O	Serial Data Frame Sync: Output if the AD1803 is configured in DSP mode, Input if the AD1803 is configured in any AC'97 mode.
SDATA_IN	7	O	Serial Data Output from AD1803.
SDATA_OUT	8	I	Serial Data Input to AD1803.

General-Purpose I/O and Barrier Interface Signals

Pin Name	TSSOP	I/O	Description
G[0]	14	I/O	General-Purpose I/O.
G[1]/ MIC	15	I	General-Purpose I/O. Or Analog MIC Input. See Bit GPMIC in Register 0x5E.
G[2]	13	I/O	General-Purpose I/O. Also used to select Serial Interface mode (see below).
G[3]/ WAKE	12	I/O	General-Purpose I/O. Or Wake Interrupt Output. See Bit GPWAK in Register 0x5E. Also used to select Serial Interface mode (see below). When serving as WAKE, this pin will be driven high if selected GPIO pins receive selected logic levels (see Registers 0x52 and 0x4E).
G[4]/ MOUT	11	I/O	General-Purpose I/O. Or Monitor Output. See Bit GPMON in Register 0x5E.
G[5]	24	I/O	General-Purpose I/O.
G[6]	23	I/O	General-Purpose I/O.
G[7]	22	I/O	General-Purpose I/O.

NOTES

- See Registers 0x4C through 0x54 and Bank 1 Register 0x60 for G[7:0] (General Purpose I/O) pin control.
- By default all G[7:0] pins serve as inputs with weak (~30 k Ω equivalent) internal pull-up devices enabled.
- Input voltage on Pins G[7:2,0] must not exceed DVDD by more than 0.3 V.
- Input voltage on Pin G[1] must not exceed AVDD by more than 0.3 V.
- The states of pins G[3:2] are sampled when $\overline{\text{RESET}}$ is deasserted (driven from LOW to HIGH) for the first time after power is applied to select AD1803 serial interface mode. Once sampled, serial interface mode can be changed only by removing power from the AD1803.

G[3]/WAKE	G[2]	Serial Interface Mode
HIGH	HIGH	AC'97 Mode—Primary Device (ID: 00)
HIGH	LOW	AC'97 Mode—Secondary Device (ID: 01)
LOW	HIGH	AC'97 Mode—Secondary Device (ID: 10)
LOW	LOW	DSP Mode

Analog Signals

Pin Name	TSSOP	I/O	Description
Rx	16	I	Receive (ADC) Input.
Tx	20	O	Transmit (DAC) Output.
FILT	17	I	ADC Filter Bypass: Requires 1 μF Capacitor to AGND.
V _{REF}	18	I	Voltage Reference: Requires 1 μF Capacitor to AGND.

PRODUCT OVERVIEW

The AD1803 is a low power 16-bit codec for modem, voice, and telephony applications. It can also be used as a cellular telephone interface.

The AD1803 is an Intel AC'97 Rev 2.1-compliant modem codec (refer to Intel's AC'97 specifications at www.intel.com) with selectable AC'97 or a DSP-style serial interface.

The AD1803 codec uses high-performance Σ - Δ ADC and DACs with programmable gain/attenuation. It has a digital Σ - Δ monitor output with selectable mix from ADC and DAC channels for call progress monitoring.

The AD1803 supports advanced power management with several power-saving modes. The codec supports seven general purpose I/O pins and a wake interrupt signaling mechanism on GPIO events.

SERIAL INTERFACE MODE SELECTION

When power is first applied to the AD1803, $\overline{\text{RESET}}$ must be asserted ($\overline{\text{RESET}}$ pin driven LOW), and kept asserted until the power has stabilized. While $\overline{\text{RESET}}$ is asserted, the AD1803's serial interface mode is chosen by the state of Pins 12 and 13:

Pin 12	Pin 13	Mode Chosen
HIGH	HIGH	AC'97 Mode—Primary Device (ID: 00)
HIGH	LOW	AC'97 Mode—Secondary Device (ID: 01)
LOW	HIGH	AC'97 Mode—Secondary Device (ID: 10)
LOW	LOW	DSP Mode

Note that Pins 12 and 13 have weak pull-up devices internal to the AD1803 which are enabled by default. Therefore, if these pins are floated, AC'97 primary mode will be chosen. When $\overline{\text{RESET}}$ is deasserted ($\overline{\text{RESET}}$ pin driven HIGH) for the first time after power is applied, the states of Pins 12 and 13 are latched locking in serial interface mode. Subsequent changes of logic level presented on Pins 12 and 13 will have no effect on serial port mode until power is removed from the AD1803.

After this first deassertion of $\overline{\text{RESET}}$, Pins 12 and 13 will take on new roles and serve as general purpose I/O control pins. The AD1803 does not need an active clock source for proper operation during this mode selection.

SERIAL INTERFACE BEHAVIOR AND PROTOCOL WHEN IN AC'97 MODE

The AD1803 serial interface is compatible with the Intel's "Audio Codec '97" Revision 2.1 specification as either a primary or secondary modem/handset codec device. Consult this specification for complete behavioral details. By default the AD1803 will use Slot 5 to send and receive sample data, but this may be changed to Slot 10 or 11. See Bits SPCHN, SPGBP, SPDSS, SPISO, and SPDL[1:0] in Register 0x5E for additional AC'97 mode configuration enhancements.

AC'97 Interface Modes

Primary Mode

Entered if GPIO[3] pin is HIGH and GPIO[2] pin is HIGH when $\overline{\text{RESET}}$ pin is deasserted first time:

AD1803 is Timing Master: Drives BIT_CLK @ 12.288 MHz

AD1803 accepts the 48 kHz SYNC Timing Signal

AD1803 requires a crystal or clock on XTALI (see Bits XTALI[1:0] in Register 0x5C for frequency).

Secondary Modes

Entered if GPIO[3] pin is HIGH and GPIO[2] pin is LOW when $\overline{\text{RESET}}$ pin is deasserted first time or if GPIO[3] pin is LOW and GPIO[2] pin is HIGH when $\overline{\text{RESET}}$ pin is deasserted first time:

AD1803 is Timing Slave: Accepts BIT_CLK @ 12.288 MHz

AD1803 accepts the 48 kHz SYNC Timing Signal

AD1803 does not require a crystal or clock on XTALI (see Bits XTALI[1:0] in Register 0x5C for frequency) unless wake from an event during $\overline{\text{RESET}}$ is desired.

AD1803

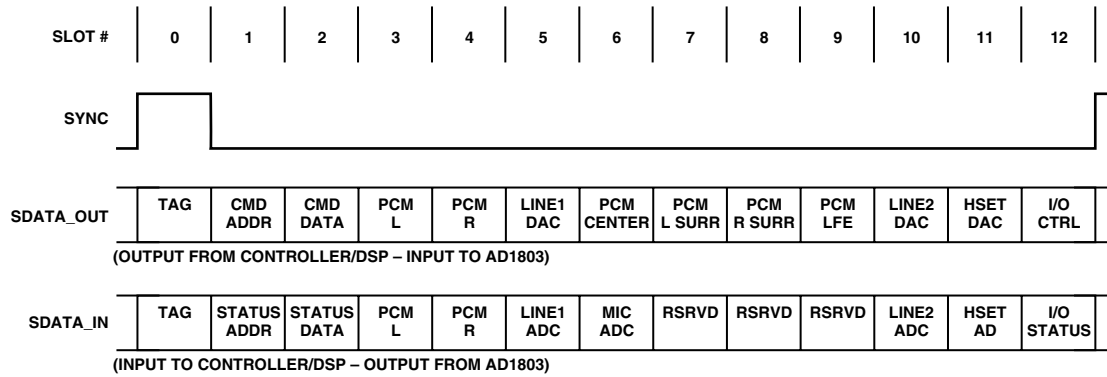

Figure 8. AC'97 Interface Timing

SERIAL INTERFACE BEHAVIOR AND PROTOCOL WHEN IN DSP MODE

In DSP mode, the AD1803 requires a clock on XTALI to do anything useful. This clock can be created by placing a crystal between pins XTALI and XTALO with appropriate trim capacitors. Alternatively, a clock can be driven directly onto the XTALI pin from an external source, in which case XTALO must be floated. When the AD1803 serial interface is configured in DSP mode, the clock presented on the XTALI pin is assumed to be 24.576 MHz. However, a 12.288 MHz or 32.768 MHz clock could be used instead, providing:

1. The AD1803 is informed via a register write what the true clock frequency is before the codec is enabled; and
2. It is acceptable to have the serial port Bit clock and frame sync run at rates different from the start-up nominal until the AD1803 is informed of the true XTALI clock frequency.

Within 1 ms after $\overline{\text{RESET}}$ is deasserted and the AD1803 receives a clock on XTALI, the AD1803 will begin driving a 4.096 MHz Bit clock onto the BIT_CLK pin (assuming a 24.576 MHz XTALI clock). Approximately 100 μs later, the AD1803 will begin driving an 8 kHz frame sync onto the SYNC pin (again assuming a 24.576 MHz XTALI clock). If the AD1803 receives an XTALI clock that is higher/lower than the expected 24.576 MHz default, these frequencies will be scaled up/down (lineally) until the AD1803 is informed of the actual XTALI clock frequency by a write to Bits XTAL[1:0] in Register 0x5C. See Bits XTAL[1:0] for further details including allowed alternate XTALI frequencies.

Each serial interface frame consists of a single 16-Bit word sent into the AD1803 on the SDATA_OUT pin, and a single 16-Bit word sent out of the AD1803 on the SDATA_IN pin. These words are simultaneously transferred during the first 16 clocks of the BIT_CLK pin after the start of a frame. The start of a frame is marked by a one BIT_CLK long HIGH pulse of the SYNC pin one BIT_CLK period before the first bit in the frame. Data is transmitted MSB first. Logic levels on all pins (SYNC, SDATA_IN, and SDATA_OUT) are updated on BIT_CLK rising edges, and should be sampled on BIT_CLK falling edges.

By default all frames are designated as *data* frames for delivery of two's complement DAC and ADC samples to and from the AD1803's codec. To deliver control information into the AD1803, the LSB of the word into the AD1803 has been stolen from what might otherwise have been DAC data to serve as a *control* frame request bit. While the AD1803 provides 16-bit ADC sample output, only 15-bit DAC sample input is

possible because of this. If the LSB of the word into the AD1803 is set to 0, no control frame is requested and the next frame will be another data frame. If the LSB of the word into the AD1803 is set to 1, a control frame is requested and the next frame will be a control frame.

When a control frame is requested, an extra frame is inserted between data frames avoiding an interruption of codec sample data flow. The 16-bit control word into the AD1803 consists of, from MSB to LSB: a register read/write request bit (0 to request a write, 1 to request a read); the six MSBs of a 7-bit register address (where the LSB is removed to save space since it's always a 0); a byte select bit (0 to select the lower byte of the 16-bit control register addressed, 1 to select the upper byte of the 16-bit control register addressed); and, finally, eight bits of data that will be written into the addressed register if a write is requested. Otherwise, these last eight bits will be ignored. While it may seem peculiar to have a 7-bit register address with an always 0 LSB consequently dropped when sent to the AD1803, it should be noted that AD1803 register addresses are defined by the AC'97 specification, whether configured in an AC'97 mode or in DSP mode. While the AC'97 2.1 specification reserves odd addresses for future feature expansion, there was not room in a DSP mode control word for this unused bit. The 16-bit control word out of the AD1803 consists of, from MSB to LSB, eight unused bits that are always 0s, followed by eight bits of data that reflect the contents of the register addressed within the current frame if a read was requested. Otherwise they are all 0s.

When serial interface frames first commence after $\overline{\text{RESET}}$ is deasserted, there will be 512 bits per frame (8 kHz frame rate/4.096 MHz bit clock rate) where only the first 16 bits per frame are typically utilized. Bits out of the AD1803 after the first 16 will typically all be set to 0, and bits into the AD1803 after the first 16 are typically ignored. However, when a control frame is requested via the *control frame request* bit in a data frame, the control frame will be inserted between data frames, and placed 256 bits after the start of the data frame that requested the control frame. This control frame will of course be marked by an additional 1-bit clock long pulse HIGH of the SYNC pin. Note that the spacing between data frames is always unaffected by the insertion of a control frame.

Although at Startup the frame rate is 8 kHz and there are exactly 512 bits from the start of one data frame to the next, this will change as soon as the codec is enabled (note that the codec is powered down by default after power is first applied to the AD1803). Whenever the codec is enabled, the frame rate will be

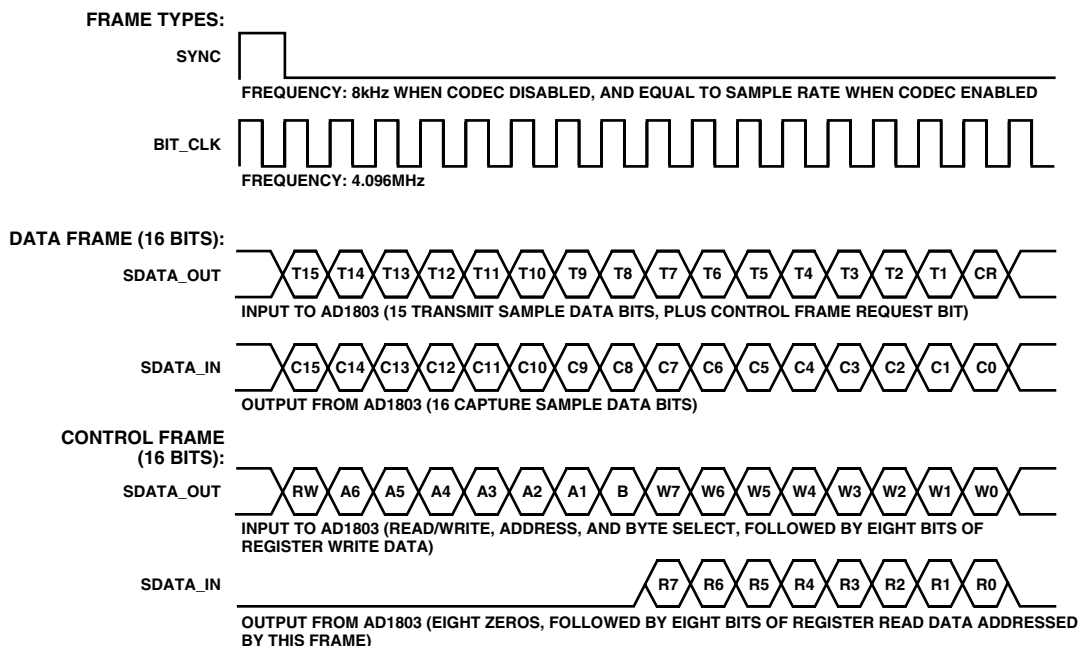

Figure 9. Frame Types

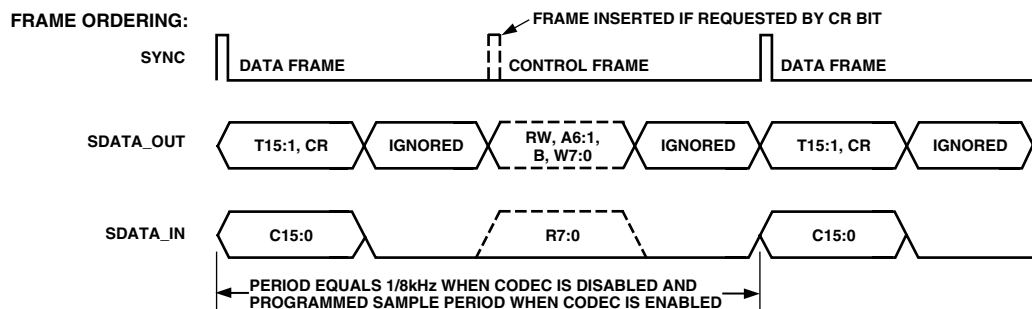

Figure 10. Frame Ordering

switched from 8 kHz to the programmed codec sample rate, and whenever the codec is powered down again, the frame rate will switch back to 8 kHz. With the bit clock always fixed at 4.096 MHz, this gives rise to a first cause of variation in the number of bits between starts of data frames. A second cause of varying number of bits between starts of data frames is the presence of a subtle jitter in the assertion of frame sync when the codec is enabled. Although on average there will be an exact match between the programmed sample rate and the frame rate, the frame sync itself will vary up to 4% of a sample period from the ideal assertion point in time.

When the serial interface is in DSP mode, it is possible to access only the upper or lower 8-bit byte of a 16-bit control register at

a time. While this is sufficient for manipulating many of the AD1803 features, some features require more than eight control bits and span multiple 8-bit bytes and/or multiple 16-bit words.

To allow all bits of a feature to take effect simultaneously, writes to certain control bytes of certain registers are actually held in holding latches until a particular control byte of the feature is written. Note that a read of a control register always returns the contents of a holding latch (if present for that register), which does not necessarily reflect the control setting currently being used by the AD1803. The only feature in the AD1803 that incorporates this complication is the codec sample rate, which writes to the lower byte of Register 0x40 and does not take effect until the upper byte of Register 0x40 is written.

AD1803

REGISTER BANKS

Register addresses are based on Intel's AC'97 specification. However, since the AC'97 specification lacks sufficient vendor-defined register space to control all extended features of the AD1803, some control registers must be accessed indirectly using register banks. See Bits BNK[1:0] in Register 0x5C for details.

REGISTER ACCESS RESTRICTIONS

Nearly all control registers may be read or written at any time. However, below is a list of restrictions that must be followed to ensure proper operation of the AD1803:

1. The clock frequency delivered to the AD1803 on XTALI must be identified (via a write to Bits XTAL[1:0] in Register 0x5C) before the codec is enabled (via a write of 0 to Bits DPDN or APDN in Register 0x3E).
2. During ADC calibration, codec sample rate (Register 0x40), and ADC source and gain level must not be changed, and digital impedance synthesis (see DISE bit in Register 0x5E) must not be enabled. Calibration is initiated each time the AD1803's ADC is enabled (see Bit APDN in Register 0x3E) and whenever a 1 is written to Bit ADCAL in Register 0x5C. Completion of calibration may be determined by polling the ADCAL bit.

GENERAL-PURPOSE I/O PIN OPERATION

Refer to Registers 0x4C through 0x54 and Bank 1 Register 0x60 for complete details. See Figure 12.

VOICE/HANDSET SUPPORT

In addition to modem applications, the AD1803 can be used for Voice/Handset support.

Table I. Voice Features

Feature	AD1803
Power Supply	3 V to 5 V
Maximum Sampling Frequency	16 kHz
Differential Handset Output	No
Single-Ended Line Output	Yes, 600 Ω Load
Output Full-Scale Range	2.2 V p-p
Output Attenuation Steps	+12 dB to -34.5 dB
Input Line/MIC Mux	Yes
Input Full-Scale Range	0.777 V rms 2.2 V p-p
Input 0 dB/20 dB Gain Block	Yes
PGA, 0 dB-22.5 dB Range	Yes
Single-Ended Input	Yes
Differential Input	No
Input Resistance	10 k Ω min Varies with Gain (See Table II)

Table II. Input Resistance vs. Gain Setting

PGA Gain (dB)	20 dB Gain Block	PGA Gain (dB)	R _{IN} (k Ω)
0.0 to 22.5	Disabled	0.0 to 22.5	100
0.0 to 22.5	Enabled	20.0 to 42.5	10

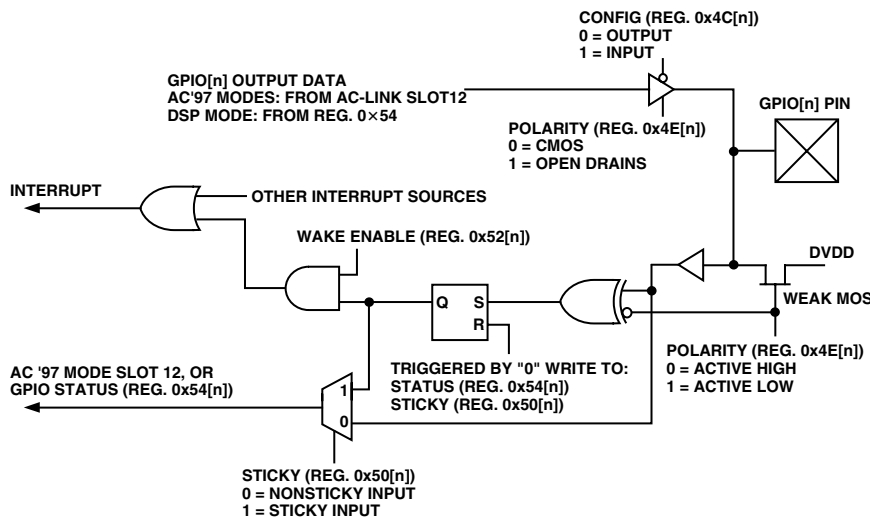

Figure 11. Conceptual Diagram of GPIO Pin Behavior

Table III. Register Summary

Direct Mapped Registers		Indirect Mapped Registers	
Address	Register Name	Address	Register Name
0x3C	Extended Modem ID		
0x3E	Extended AD1803 Status and Control		
0x40	Line DAC/ADC Sample Rate Control		
0x46	AD1803 DAC/ADC Level Control		
0x4C	GPIO Pin Configuration		
0x4E	GPIO Pin Polarity/Type		
0x50	GPIO Pin Sticky		
0x52	GPIO Pin Wake-Up Mask	0x60 In Bank 1	AD1803 GPIO Initial States
0x54	GPIO Pin Status		
0x56	Misc. Modem AFE Status and Control	0x64 In Bank 1	AD1803 Clock Pad Control
0x5C	AD1803 Configuration 1	0x60 In Bank 2	AD1803 Monitor Output Control
0x5E	AD1803 Configuration 2		
0x7A	AD1803 Version ID		
0x7C	Vendor ID1		
0x7E	Vendor ID2		

Table IV. Register Bit Mapping

Adr/Bnk	Default	D15	D14	D13	D12	D11	D10	D9	D8	D7	D6	D5	D4	D3	D2	D1	D0
0x3C		ID1	ID0	0	0	0	0	0	0	0	0	0	0	0	0	0	LIN1
0x3E	0xFF00	Res	Res	Res	Res	DPDN	APDN	VPDN	GPDN	0	0	0	0	DSTA	ASTA	VSTA	GSTA
0x40	0x3E80	SRG1	SRG0	SR13	SR12	SR11	SR10	SR9	SR8	SR7	SR6	SR5	SR4	SR3	SR2	SR1	SR0
0x46	0x8080	DAM	0	0	DAL4	DAL3	DAL2	DAL1	DAL0	ADM	0	ADS	ADG20	ADL3	ADL2	ADL1	ADL0
0x4C	0x00FF	0	0	0	0	0	0	0	0	GC7	GC6	GC5	GC4	GC3	GC2	GC1	GC0
0x4E	0x00FF	0	0	0	0	0	0	0	0	GP7	GP6	GP5	GP4	GP3	GP2	GP1	GP0
0x50	0x0000	0	0	0	0	0	0	0	0	GS7	GS6	GS5	GS4	GS3	GS2	GS1	GS0
0x52	0x0000	0	0	0	0	0	0	0	0	GW7	GW6	GW5	GW4	GW3	GW2	GW1	GW0
0x54	0x00FF	0	0	0	0	0	0	0	0	GI7	GI6	GI5	GI4	GI3	GI2	GI1	GI0
0x56	0x0000	0	0	0	MLNK	0	0	0	0	0	0	0	0	0	L1B2	L1B1	L1B0
0x5C	0x18C0	Res	BNK1	BNK0	R34PM	XTAL1	XTAL0	ACSEL	ADCAL	CLKED	CLKEA	Res	Res	Res	Res	Res	Res
0x5E	0x0018	GPBAR	GPWAK	GPMON	GPMIC	SPCHN	SPGBP	SPDSS	SPISO	SPDL1	SPDL0	Res	Res	Res	Res	Res	Res
0x60/1		0	0	0	0	0	0	0	0	GPIV7	GPIV6	GPIV5	GPIV4	GPIV3	GPIV2	GPIV1	GPIV0
0x64/1	0x0077	0	0	0	0	0	0	0	0	Res	Res	Res	Res	XTLP	COS2	COS1	COS0
0x60/2	0x4000	MMD1	MMD0	MDM	MDL4	MDL3	MDL2	MDL1	MDL0	Res	Res	MAM	MAL4	MAL3	MAL2	MAL1	MAL0
0x7A	0x0002	0	0	0	0	0	0	0	0	VER7	VER6	VER5	VER4	VER3	VER2	VER1	VER0
0x7C	0x4144	0	1	0	0	0	0	0	1	0	1	0	0	0	1	0	0
0x7E	0x5380	0	1	0	1	0	0	1	1	1	0	0	0	0	0	0	0

Res = Reserved Bit. To ensure future compatibility, reserved bits should be set to "0" when written and ignored when read.

AD1803

REGISTER DESCRIPTION

Extended Modem ID Register

Address 0x3C

D15	D14	D13	D12	D11	D10	D9	D8	D7	D6	D5	D4	D3	D2	D1	D0
ID1	ID0	0	0	0	0	0	0	0	0	0	0	0	0	0	LIN1

A write to this register has no effect on the states of bits within this register, but does trigger Register 0x3E and Bank 2 Register 0x60 to be cleared to their default states, which powers down the AD1803's codec resources.

ID[1:0] Interface Identification. These bits may be read to determine the AD1803's serial interface mode of operation. Serial interface mode is chosen by the states of Pins 13 and 12 when $\overline{\text{RESET}}$ is deasserted ($\overline{\text{RESET}}$ pin driven from LOW to HIGH) for the first time after power is applied to the AD1803.
 00 = AC-Link Primary (mode chosen if Pin 12 is HIGH and Pin 13 is HIGH on first deassertion of $\overline{\text{RESET}}$).
 01 = AC-Link Secondary (mode chosen if Pin 12 is HIGH and Pin 13 is LOW on first deassertion of $\overline{\text{RESET}}$).
 10 = AC-Link Secondary (mode chosen if Pin 12 is LOW and Pin 13 is HIGH on first deassertion of $\overline{\text{RESET}}$).
 11 = DSP-Link (mode chosen if Pin 12 is LOW and Pin 13 is LOW on first deassertion of $\overline{\text{RESET}}$).

LIN1 Modem Line 1 Supported. For AC'97 compatibility, this bit returns a 1 when read to indicate that the AD1803 supports AC'97 modem line 1 features.

Extended AD1803 Status and Control

Default = 0xFF00

Address 0x3E

D15	D14	D13	D12	D11	D10	D9	D8	D7	D6	D5	D4	D3	D2	D1	D0
Res	Res	Res	Res	DPDN	APDN	VPDN	GPDN	0	0	0	0	DSTA	ASTA	VSTA	GSTA

Res = Reserved Bit. To ensure future compatibility, reserved bits should be set to "0" when written and ignored when read.

This register is forced to its default when: 1) Power is first applied to the AD1803; 2) The $\overline{\text{RESET}}$ pin is driven LOW; or 3) Register 0x3C is written with any value.

DPDN AD1803 DAC Power-Down. When this bit is set to 1 (default), all DAC resources within the AD1803 will be powered down, and all DAC data sent to the AD1803 over the serial interface will be ignored. When this bit is set to 0, the digital DAC resources within the AD1803 will be powered up, but the analog DAC resources within the AD1803 will be powered up only if the AD1803's voltage reference is powered up (Bit VPDN in this register set to 0), and the AD1803's analog codec is selected as the partner to the AD1803's digital codec (Bit ACSEL in Register 0x5C set to 0).
 0 = Enable AD1803 Digital DAC Resources, Conditionally Enable AD1803 Analog DAC Resources.
 1 = Power-Down All AD1803 DAC Resources (default).

APDN AD1803 ADC Power-Down. When this bit is set to 1 (default), all ADC resources within the AD1803 will be powered down, and all ADC data words sent out of the AD1803 over the serial interface will be midscale (zero) (and tagged invalid if the serial interface is configured in an AC'97 mode). When this bit is set to 0, the digital ADC resources within the AD1803 will be powered up, but the analog ADC resources within the AD1803 will be powered up only if both the AD1803's voltage reference is powered up (Bit VPDN in this register set to 0), and the AD1803's analog codec is selected as the partner to the AD1803's digital codec (Bit ACSEL in Register 0x5C set to 0). Each time the AD1803's analog codec is powered up, an ADC DC offset calibration is automatically initiated. This calibration requires approximately 104 sample periods (defined by Register 0x40), but cannot be started until after the AD1803's voltage reference is powered up (by setting Bit VPDN in this register to 0), which itself requires about 48 ms. Bit VSTA in this register may be polled first to determine if the voltage reference is powered up, and then Bit ADCAL in Register 0x5C may be polled to determine if calibration is completed. During calibration, codec sample rate, ADC source, and ADC gain level must not be changed.
 0 = Enable AD1803 Digital ADC Resources, Conditionally Enable AD1803 Analog ADC Resources.
 1 = Power-Down All AD1803 ADC Resources (default).

VPDN AD1803 Voltage Reference Power-Down. Writes to this bit initiate codec voltage reference power-up and power-down sequences. Bit VSTA in this register may be polled to monitor current voltage reference status. Until the voltage reference is fully powered up, the AD1803's analog ADC and DAC channels will ignore the setting of Bits APDN and DPDN and remain powered down.
 0 = Enable Voltage Reference.
 1 = Power-Down Voltage Reference (default).

- GPDN** AD1803 GPIO Power-Down. The setting of this bit affects the behavior of the AD1803 only when it is configured in an AC'97 mode (see Register 0x3C). This bit determines whether or not the logic levels received on the AD1803's GPIO (general purpose IO) pins are reflected on bits in Slot 12 of the AC'97 link, and whether or not the states of bits in Slot 12 determine the logic levels to drive out of GPIO pins that are configured as outputs. See Bit SPGBP in Register 0x5E for mapping. Contrary to the AC'97 specification, the setting of this bit does not actually control the power-up/down state of GPIO pins. AD1803 GPIO pins are always powered up and always perform the functions they are assigned by the programming of Registers 0x4C through 0x54 and Register 0x5E.
- 0 = Slot 12 Output Bits Reflect Logic Levels Received on GPIO Pins.
Slot 12 Input Bits Determine Logic Levels to Drive out GPIO Pins Configured as Outputs.
- 1 = Slot 12 Output Bits All 0 (default).
Slot 12 Input Bits are Ignored.
- DSTA** AD1803 DAC Status. This bit exists solely for AC'97 compatibility. Its purpose is to provide a handshake for DAC power-up/-down status changes initiated by writes to Bit DPDN in this register. However, since the AD1803 will respond to a write of Bit DPDN prior to it being possible to read this bit in a following serial interface frame, it's pointless to poll this status bit. Writes to this bit have no effect on AD1803 behavior.
- ASTA** AD1803 ADC Status. This bit exists solely for AC'97 compatibility. Its purpose is to provide a handshake for ADC power-up/-down status changes initiated by writes to Bit APDN in this register. However, since the AD1803 will respond to a write of Bit APDN prior to it being possible to read this bit in a following serial interface frame, it's pointless to poll this status bit. Writes to this bit have no effect on AD1803 behavior.
- VSTA** AD1803 Voltage Reference Status. This bit may be polled to monitor the status of the AD1803's codec voltage reference. When read as a 0, the voltage reference is either powered down or in the process of powering up. When read as a 1, the voltage reference is either powered up or in the process of powering down. Approximately 48 ms after Bit VPDN in this register is set to a 0, this bit will transition from a 0 to a 1 indicating that the voltage reference is fully powered up. Approximately 0.8 ms after VPDN is set to a 1, this bit will transition from a 1 to a 0 indicating that the voltage reference is fully powered-down. If a clock is driven onto the AD1803's XTALI pin (rather than generated by a crystal placed between the XTALI and XTALO pins), and it is desired to stop this clock for additional system power savings, this clock must not be stopped until after this bit falls to a 0. Writes to this bit have no effect on AD1803 behavior.
- GSTA** AD1803 GPIO Status. This bit exists solely for AC'97 compatibility. Its purpose is to provide a handshake for DAC power-up/-down status changes initiated by writes to Bit GPDN in this register. However, since the AD1803 will respond to a write of Bit GPDN prior to it being possible to read this bit in a following serial interface frame, it is pointless to poll this status bit. Writes to this bit have no effect on AD1803 behavior.

Line DAC/ADC Sample Rate Control													Default = 0x3E80			Address 0x40		
D15	D14	D13	D12	D11	D10	D9	D8	D7	D6	D5	D4	D3	D2	D1	D0			
SRG1	SRG0	SR13	SR12	SR11	SR10	SR9	SR8	SR7	SR6	SR5	SR4	SR3	SR2	SR1	SR0			

This register is forced to its default only when power is first applied to the AD1803.

This register must not be written while an ADC calibration is in progress (see Bit APDN in Register 0x3E and Bit ADCAL in Register 0x5C).

When the AD1803 serial interface is configured in DSP mode, writes to the lower byte of this register are temporarily placed in a holding register and do not actually take effect until the upper byte is written. This ensures that the 16-bit sample rate takes effect only as a whole. Reads of the lower byte of this register return the contents of this holding register which does not necessarily reflect the current sample rate.

- SRG[1:0]** Sample Rate Granularity. Together with Bits P4MS[1:0] in Register 0x5C, these bits select the LSB weighting of the Bits SR[13:0] (Sample Rate Select). These bits select a fundamental LSB weighting of either 1 Hz, 8/7 Hz, or 10/7 Hz for Bits SR[13:0], while Bits P4MS[1:0] may be used to put the codec in a low power mode in which case these fundamental LSB weightings are cut in half.
- 00 = SR[13:0] LSB Weight Is 1 Hz If P4MS[1:0] != 10 (default), Or 1/2 Hertz If P4MS[1:0] = 10.
01 = SR[13:0] LSB Weight Is 8/7 Hz If P4MS[1:0] != 10, Or 4/7 Hz If P4MS[1:0] = 10.
10 = SR[13:0] LSB Weight Is 10/7 Hz If P4MS[1:0] != 10, Or 5/7 Hz If P4MS[1:0] = 10.
11 = Reserved.

AD1803

SR[13:0] Sample Rate Select. Together with Bits SRG[1:0] (Sample Rate Granularity) and Bits P4MS[1:0] in Register 0x5C, these bits define the sample rate for both the ADC and DAC codec channels. Permitted settings of SR[13:0] range from 6400 to 16000 when SRG[1:0] = 00, 5600 to 14000 when SRG[1:0] = 01, and 4480 to 11200 when SRG[1:0] = 10. Resultant sample rate, regardless of SRG[1:0] setting, always ranges from 6,400 Hz to 16,000 Hz if the codec is not in low power mode (P4MS[1:0] 1 = 10), and ranges from 3,200 Hz to 8,000 Hz if the codec is in low power mode (P4MS[1:0] = 10). The default sample rate is 16000 Hz.

AD1803 DAC/ADC Level Control											Default = 0x8080					Address 0x46
D15	D14	D13	D12	D11	D10	D9	D8	D7	D6	D5	D4	D3	D2	D1	D0	
DAM	0	0	DAL4	DAL3	DAL2	DAL1	DAL0	ADM	0	ADS	ADG20	ADL3	ADL2	ADL1	ADL0	

This register is forced to its default only when power is first applied to the AD1803.

The states of Bits ADS, ADG20, and ADL[3:0] in this register must not be changed while an ADC calibration is in progress if the AD1803's analog codec is in use (see Bit APDN in Register 0x3E and Bit ADCAL in Register 0x5C).

- DAM** DAC Mute.
0 = DAC Output Enabled.
1 = DAC Output Muted (Forced to Midscale) (default).
- DAL[4:0]** DAC Attenuation Level Select. Least significant bit represents -1.5 dB. This attenuation is valid when the AD1803's analog codec is used with the AD1803's digital codec (Bit ACSEL in Register 0x5C = 0)
00000 = +12.0 dB Gain (default).
11111 = -34.5 dB Attenuation.
- ADM** ADC Mute.
0 = ADC Samples Passed.
1 = ADC Samples Substituted with Midscale (Zero) Data (default).
- ADS** AD1803 Analog ADC Input Select. The state of this bit has no effect on ADC behavior unless Bit ACSEL in Register 0x5C is set to 0 (default). This selects the AD1803's analog codec to partner the AD1803's digital codec. If this bit will be used to select the MIC input as the AD1803's ADC input, Pin 15 must first be assigned to serve as this MIC input rather than its default role as a GPIO (General Purpose IO) pin. This is done by setting Bit GPMIC in Register 0x5E to 1.
0 = Pin 16 (Rx Input) Selected As AD1803 ADC Input Source (default).
1 = Pin 15 (MIC Input) Selected As AD1803 ADC Input Source (requires GPMIC in Register 0x5E set to 1).
- ADG20** AD1803 Analog ADC 20 dB Gain Enable. The state of this bit has no effect on ADC behavior unless Bit ACSEL in Register 0x5C is set to 0 (default). This selects the AD1803's analog codec to partner the AD1803's digital codec. Total ADC gain will be the summation due to this bit and Bits ADL[3:0].
0 = 0 dB Gain (default).
1 = 20 dB Gain.
- ADL[3:0]** AD1803 ADC Gain Level Select. The state of these bits has no effect on ADC behavior unless Bit ACSEL in Register 0x5C is set to 0 (default). This selects the AD1803's analog codec to partner the AD1803's digital codec. Total ADC gain will be the summation due to these bits and Bits ADG20. Least significant bit represents 1.5 dB.
0000 = 0.0 dB Gain (default).
1111 = 22.5 dB Gain.

GPIO Pin Configuration											Default = 0x00FF					Address 0x4C
D15	D14	D13	D12	D11	D10	D9	D8	D7	D6	D5	D4	D3	D2	D1	D0	
0	0	0	0	0	0	0	0	GC7	GC6	GC5	GC4	GC3	GC2	GC1	GC0	

This register is forced to its default only when power is first applied to the AD1803.

- GC[7:2,0]** General Purpose IO Pin Configuration. These bits define the directionality of GPIO pins with corresponding numbers. By default, all GPIO pins serve as inputs but with weak (~100 μ A with a 3.3 V supply, ~140 μ A with a 5.0 V supply) pull-up devices internal to the AD1803 enabled. See Register 0x4E to disable these weak pull-up devices. Note that GPIO Pin 1 is always an input and cannot serve as an output. Also note that bits in this register will be ignored if the GPIO pin they control has been assigned to serve an alternate special purpose (see bits in Register 0x5E). Care must be taken to insure that GPIO pin input voltages never exceed GPIO supply and ground voltages by more than 0.3 V. GPIO Pin 1 is source by the analog supply (Pins AVDD and AGND). All other GPIO pins are sourced by the digital supply (Pins DVDD and DGND).
0 = GPIO Pin Serves as an Output.
1 = GPIO Pin Serves as an Input (default).

GPIO Pin Polarity/Type															Default = 0x00FF	Address 0x4E
D15	D14	D13	D12	D11	D10	D9	D8	D7	D6	D5	D4	D3	D2	D1	D0	
0	0	0	0	0	0	0	0	GP7	GP6	GP5	GP4	GP3	GP2	GP1	GP0	

This register is forced to its default only when power is first applied to the AD1803.

GP[7:0] GPIO[7:0] Input Polarity/Output Driver Type Select. These bits control GPIO pins with corresponding numbers. The effect they have is dependent on GPIO pin directionality (see Register 0x4C). When a GPIO pin serves as an input, these bits select the logic level necessary to set a sticky status bit which is used to trigger an interrupt (see Registers 0x50 and 0x52). Also when serving as an input, these bits determine whether or not a weak pull-up device within the AD1803 on each GPIO pin is enabled. If an input is set to active HIGH, and therefore nominally receives a LOW, the weak pull-up is disabled. If an input is set to active LOW, and therefore nominally receives a HIGH, the weak pull-up is enabled. Meanwhile, when a GPIO pin serves as an output, these bits determine the type of output driver activated: Either CMOS or open drain with weak pull-up.

If a GPIO pin is defined as an Input (corresponding GC bit in Register 0x4C set to 1)

0 = Input Is Active High, Weak Pull-Up Disabled.

1 = Input Is Active Low, Weak Pull-Up Enabled (default).

If a GPIO pin is defined as an Output (corresponding GC bit in Register 0x4C set to 0).

0 = Output Driver Is CMOS.

1 = Output Driver Is Open Drain with Weak Pull-Up Enabled (default).

GPIO Pin Sticky															Default = 0x0000	Address 0x50
D15	D14	D13	D12	D11	D10	D9	D8	D7	D6	D5	D4	D3	D2	D1	D0	
0	0	0	0	0	0	0	0	GS7	GS6	GS5	GS4	GS3	GS2	GS1	GS0	

This register is forced to its default only when power is first applied to the AD1803.

GS[7:0] GPIO[7:0] Sticky Control. These bits control GPIO pins with corresponding numbers. They determine whether a read of Register 0x54 returns either the current logic level received on a GPIO pin, or a sticky status bit which indicates if a selected logic level (see Register 0x4E) has been received since this sticky status bit was last cleared. Sticky status bits are cleared by writes to their associated control bits in Register 0x54, and whenever the current GPIO pin received logic level is selected as the Register 0x54 return value.

0 = Reads of Register 0x54 Return Current State of GPIO Pin, Sticky Status Bit Cleared (default).

1 = Reads of Register 0x54 Return Sticky Status Bit Set by GPIO Pin Level Selected by Register 0x4E.

GPIO Pin Wake-Up Mask															Default = 0x0000	Address 0x52
D15	D14	D13	D12	D11	D10	D9	D8	D7	D6	D5	D4	D3	D2	D1	D0	
0	0	0	0	0	0	0	0	GW7	GW6	GW5	GW4	GW3	GW2	GW1	GW0	

This register is forced to its default only when power is first applied to the AD1803.

GW[7:0] GPIO[7:0] Wake-Up Mask Control. A GPIO pin will trigger an interrupt providing: 1) It is enabled to cause interrupts by the corresponding numbered bit in this register, and 2) It has its associated sticky status bit set. For the associated sticky status bit to be set, the GPIO input must first be enabled to be sticky by the GS bit in Register 0x50, and then the logic level selected by a GP bit in Register 0x4E must be received on the associated GPIO pin. While an interrupt is triggered, Pin 12 will be driven HIGH providing Pin 12 is enabled to serve as an interrupt output (see GPWAK bit in Register 0x5E). If the AD1803's serial interface is configured in an AC'97 mode, interrupts are also reflected on Bit 0 of Slot 12 of each frame, even if Pin 12 is not enabled to respond to an interrupt. Also in AC'97 mode, if $\overline{\text{RESET}}$ is asserted when an interrupt is triggered, the SDATA_IN pin will be driven from LOW (its default during $\overline{\text{RESET}}$) to HIGH to wake an AC'97 controller. Refer to the AC'97 specification for complete details. Interrupts can be triggered by activated GPIO pins. The source of the interrupt may be determined by reading Register 0x54.

0 = GPIO Pin Disabled from Causing Interrupts (default).

1 = GPIO Pin Enabled to Cause Interrupts (providing corresponding GS bit in Register 0x50 = 1).

AD1803

GPIO Pin Status

Default = 0x00FF

Address 0x54

D15	D14	D13	D12	D11	D10	D9	D8	D7	D6	D5	D4	D3	D2	D1	D0
0	0	0	0	0	0	0	0	GI7	GI6	GI5	GI4	GI3	GI2	GI1	GI0

This register is forced to its default only when power is first applied to the AD1803.

GI[7:0] GPIO[7:0] Status. Each bit corresponds with a GPIO pin of the same number. When a bit is read, it reflects either the current logic level received on a GPIO pin, or the state of sticky status bit, which is set if a selected logic level has been received on a GPIO pin since the last time the sticky status bit was cleared (see Registers 0x4E, 0x50, and 0x52). When a bit is written with a 0, the associated sticky status bit is cleared. Note that it is not necessary to write a 1 to a bit after writing a 0 since it is the act of writing a 0 to a bit itself that clears the sticky status bit. When a bit is written with a 1, the associated sticky status bit is unaffected. If the AD1803's serial interface is configured in DSP mode (see Register 0x3C), then writes to this register also control the logic level driven out on the GPIO pins provided that a GPIO pin is configured as an output (see Register 0x4C) and is serving as a GPIO pin (see Register 0x5E). (If the AD1803's serial interface is configured in an AC'97 mode, GPIO output states are determined by bits in AC-link Slot 12 rather than writes to this register. See Bit SPGBP in Register 0x5E and the AC'97 specification for further details.)

Miscellaneous Modem AFE Status and Control

Default = 0x0000

Address 0x56

D15	D14	D13	D12	D11	D10	D9	D8	D7	D6	D5	D4	D3	D2	D1	D0
0	0	0	MLNK	0	0	0	0	0	0	0	0	0	LIB2	LIB1	LIB0

This register is forced to its default only when power is first applied to the AD1803.

MLNK AC-Link Disable. This bit has no effect on the behavior of the AD1803 unless it is configured as an AC'97 primary device (see Register 0x3C). When this is the case, writing a 1 to this bit puts the AC'97 link interface into a sleep mode by causing the AD1803 to drive the BIT_CLK pin low within one BIT_CLK period after the completion of Slot 2 (the slot in which writes to control registers occur). While in this sleep mode, an AC'97 controller can wake the AD1803 interface either by pulsing the SYNC pin, or by asserting and then deasserting the $\overline{\text{RESET}}$ pin. Refer to the AC'97 specification for complete details. Note that the interface will also be put to sleep, regardless of interface mode, if the $\overline{\text{RESET}}$ pin is asserted.

LIB[2:0] AD1803 Loop-Back Modes.
 000 = No Loop-Back: Normal Signal Pathways Engaged (default).
 001 = Analog Back: Analog ADC Output to Analog DAC Input (At Analog Interface to Digital Codec).
 010 = Local Loop-Back: DAC Output to ADC Input (At Analog Pins).
 011 = Digital Loop-Back: Digital DAC Output to Digital ADC Input (At Digital Interface to Analog Codec).
 1xx = No Loop-Back: Normal Signal Pathways Engaged.

AD1803 Configuration 1

Default = 0x18C0

Address 0x5C

D15	D14	D13	D12	D11	D10	D9	D8	D7	D6	D5	D4	D3	D2	D1	D0
Res	BNK1	BNK0	R34PM	XTAL1	XTAL0	ACSEL	ADCAL	CLKED	CLKEA	Res	Res	Res	Res	Res	Res

Res = Reserved Bit. To ensure future compatibility, reserved bits should be set to "0" when written and ignored when read.

This register is forced to its default only when power is first applied to the AD1803.

BNK[1:0] Register Bank Select. Since the AC'97 specification lacks sufficient vendor-specified register space to control all extended features of the AD1803, some control registers must be accessed indirectly using register banks selected by these bits.
 00 = Reserved.
 01 = Bank 1: AD1803 I/O Control Registers.
 10 = Bank 2: AD1803 Codec Control Registers.
 11 = Reserved.

R34PM AD1803 Power Mode Select. When this bit is set to 0, the AD1803 will be completely powered down whenever the $\overline{\text{RESET}}$ pin is asserted (driven LOW). This bit overrides the settings of all other power control bits within the AD1803, and may be used to achieve a greater power savings than powering down all resources individually since

this bit also disables internal clocks. When this bit is set to 1, various features of the AD1803 will remain powered up during $\overline{\text{RESET}}$ as individually enabled by their related control bits (see other bits in this register).

0 = During $\overline{\text{RESET}}$, Completely Power-Down the AD1803.

1 = During $\overline{\text{RESET}}$, Allow Enabled Features to Remain Powered Up (default).

XTAL[1:0]

Clock Identification. With the exception of the serial interface, which is always clocked by the BIT_CLK pin, these bits identify the clock source and frequency to be used by all other resources within the AD1803. The default setting of these bits is dependent on the chosen AD1803 serial interface configuration (see Register 0x3C).

There are three reasons why it might be desirable to alter from the default setting:

1. If the BIT_CLK is the default clock source, but the BIT_CLK has excessive edge noise which would interfere with codec performance, than a crystal or other clean clock source could be taken from the XTALI pin instead;
2. If the BIT_CLK is the default clock source, but the BIT_CLK will be stopped during a period of time when AD1803 functionality is still necessary, such as ring validation and wake-up signalling during D3-Cold, then the clock source could be switched to the XTALI pin while the BIT_CLK is suspended;
3. If the XTALI is the default clock source, and the default crystal frequency is not the one actually used, then the correct crystal frequency must be identified prior to the ADC, DAC, or barrier interface being enabled (see Register 0x3E). Also note that if the AD1803 is the master of BIT_CLK (serial interface in AC'97 primary mode or DSP mode), than BIT_CLK cannot be at its proper frequency until the AD1803 is informed what clock frequency it is receiving. Until then the BIT_CLK frequency will be off by the ration of the actual to the default assumed frequency. As a final caution, if the clock frequency is chosen to be 32.768 MHz (setting 01 of these bits), and the AD1803 is chosen to be an AC'97 primary device, then the AD1803 will be incapable of producing the AC'97 specified 12.288 MHz BIT_CLK since there is no integer divisor between these frequencies. In this situation, the AD1803 will violate the AC'97 specification and output a 16.384 MHz BIT_CLK.

00 = 12.288 MHz From BIT_CLK (default if in an AC'97 secondary mode).

01 = 32.768 MHz From XTALI.

10 = 24.576 MHz From XTALI (default if in either AC'97 primary mode or DSP mode).

11 = 12.288 MHz From XTALI.

ACSEL

Analog Codec Select. This bit selects the analog codec that will be used in conjunction with the AD1803's digital codec.

0 = AD1803 Analog Codec Selected (default).

1 = Reserved.

ADCAL

ADC Calibration/Recalibration. Writing a 1 to this bit initiates a dc offset calibration of the codec's ADC channel which requires approximately 104 sample periods (defined by Register 0x40). ADC calibration is automatic each time an AD1803's analog ADC is enabled. When this bit is read, a 1 will be returned if calibration is in progress, and a 0 will be returned when calibration is completed, or not in progress. During calibration, the ADC will return midscale (zero) samples. Also during calibration, codec sample rate, ADC source, and ADC gain must not be changed.

CLKED

CLKOUT Enable While $\overline{\text{RESET}}$ Is Deasserted (Driven HIGH). This bit controls the operation of the CLKOUT pin while the $\overline{\text{RESET}}$ pin is deasserted. See Bit CLKEA for CLKOUT operation while $\overline{\text{RESET}}$ is asserted. Each time $\overline{\text{RESET}}$ is deasserted (driven from LOW to HIGH) this bit is automatically set to 1 to insure that a clock is always available to hardware outside the AD1803 after a $\overline{\text{RESET}}$. If this clock is not needed, this bit should be set to 0 by software after each $\overline{\text{RESET}}$ for optimal power savings.

0 = When $\overline{\text{RESET}}$ Is Deasserted: CLKOUT Driven LOW.

1 = When $\overline{\text{RESET}}$ Is Deasserted: CLKOUT Reflects Clock On XTALI (default after deassertion of $\overline{\text{RESET}}$).

CLKEA

CLKOUT Enable While $\overline{\text{RESET}}$ Is Asserted (Driven LOW). This bit controls the operation of the CLKOUT pin while the $\overline{\text{RESET}}$ pin is asserted. See Bit CLKED for CLKOUT operation while $\overline{\text{RESET}}$ is deasserted. If Bit R34PM is set to 0, this bit will be ignored, and CLKOUT will be driven LOW while $\overline{\text{RESET}}$ is asserted.

0 = When $\overline{\text{RESET}}$ Is Asserted: CLKOUT Driven LOW.

1 = When $\overline{\text{RESET}}$ Is Asserted: CLKOUT Reflects Clock Received On XTALI (providing R34PM set to 1) (default).

AD1803

Configuration 2

Default = 0x0018

Address 0x5E

D15	D14	D13	D12	D11	D10	D9	D8	D7	D6	D5	D4	D3	D2	D1	D0
GPBAR	GPWAK	GPMON	GPMIC	SPCHN	SPGBP	SPDSS	SPISO	SPDL1	SPDL0	Res	Res	Res	Res	Res	Res

Res = Reserved Bit. To ensure future compatibility, reserved bits should be set to “0” when written and ignored when read.

This register is forced to its default only when power is first applied to the AD1803.

GPBAR	GPIO Interface Select. 0 = Use AD1803 Pins 24, 23, 22 as GPIO[5], GPIO[6], GPIO[7] respectively (default). 1 = Reserved.
GPWAK	GPIO[3]/Wake Interrupt Signal Select. 0 = Use AD1803 Pin 12 as GPIO[3] (default). 1 = Use AD1803 Pin 12 as Wake Interrupt (see Register 0x52).
GPMON	GPIO[4]/Monitor Out Select. 0 = Use AD1803 Pin 11 as GPIO[4] (default). 1 = Use AD1803 Pin 11 as Σ - Δ Monitor Output (see Bank 2 Register 0x60).
GPMIC	GPI[1] / MIC Input Select. 0 = Use AD1803 Pin 15 as GPI[1] (default). 1 = Use AD1803 Pin 15 as Analog MIC Input (see Bit ADS in Register 0x46).
SPCHN	ADI Serial Port Chaining Mode Enabled. This bit is ignored unless the AD1803 is in an AC'97 serial interface mode (see Register 0x3C). This bit may be used to allow multiple AC'97 devices to be chained on a single 4-wire AC'97 link. Consult Analog Devices for further details. 0 = ADI Chaining Mode Disabled (default). 1 = ADI Chaining Mode Enabled.
SPGBP	Serial Port GPIO Bit Placement Select. This bit is ignored unless the AD1803 is configured in an AC'97 serial interface mode (see Register 0x3C). Writes to this bit take effect on the current serial interface frame. 0 = State of AD1803 GPIO Pins 7:0 Reflected on Bits <11:4> of Slot 12 (default). 1 = State of AD1803 GPIO Pins 7:0 Reflected on Bits <19:12> of Slot 12.
SPDSS	Serial Port Data Slot Size Select. This bit is ignored unless the AD1803 is configured in an AC'97 serial interface mode (see Register 0x3C). When set to 1, the four LSBs of all 20-bit data slots are dropped, allowing for a simpler connection with a DSP. Writes to this bit take effect during the current frame, but may distort the current frames slot alignment. As a result, when the state of this bit is changed, all data slots sent to the AD1803 should be set to zero, and all data slots received from the AD1803 should be ignored. 0 = Data Slots Are 20 Bits (default). 1 = Data Slots Are 16 Bits.
SPISO	Serial Port Isolate. When this bit is set to 1, the AD1803 serial interface will be isolated from the outside system whenever $\overline{\text{RESET}}$ is asserted. This is achieved by ignoring the signals received on serial interface input pins, and driving serial interface output pins weakly, less than 200 μA , rather than with nominal output drive strengths. This bit should be set to 1 prior to a controller on the other side of the AD1803's serial interface losing power if the AD1803 will continue to receive power. It may also be set to 1 to save power if the AD1803's serial interface input pins will continue to make transitions while $\overline{\text{RESET}}$ is asserted.
SPDL[1:0]	Serial Port Data Slot Location Select. These bits are ignored unless the AD1803 is configured in an AC'97 serial interface mode (see Register 0x3C). Writes to these bits take effect during the current frame, but data sent during the current frame may be distorted or dropped. For reliable operation, these bits should not be changed while the codec is enabled. 00 = AD1803 Uses Slot 5 to Send and Receive Sample Data (default). 01 = AD1803 Uses Slot 10 to Send and Receive Sample Data. 10 = AD1803 Uses Slot 11 to Send and Receive Sample Data. 11 = Reserved.

GPIO Initial States

Address 0x60 Bank 1

D15	D14	D13	D12	D11	D10	D9	D8	D7	D6	D5	D4	D3	D2	D1	D0
0	0	0	0	0	0	0	0	GPIV7	GPIV6	GPIV5	GPIV4	GPIV3	GPIV2	GPIV1	GPIV0

GPGPIV[7:0] GPIO Pin Initial Value. When $\overline{\text{RESET}}$ is deasserted for the first time after power is applied to the AD1803, the states of all GPIO (General Purpose IO) pins are sampled and stored in this register. Writes to this register and subsequent logic level changes on GPIO pins will have no effect on the values reported by reads of this register. While the sampled states of GPIO Pins 2 and 3 are used by the AD1803 to determine serial interface mode (see Register 0x3C), all remaining GPIO pins are available for use, if beneficial, as identification bits to host software or hardware. Immediately after power is first applied to the AD1803, all GPIO pins by default serve as inputs but with weak pull-up devices internal to the AD1803 enabled. Since these pull-up devices have an effective resistance of about 30 k Ω , external resistors of less than 8 k Ω tied to digital ground (DGND pin) must be used for logic lows to be sampled.

Clock Pad Control

Default = 0x0077

Address 0x64 Bank 1

D15	D14	D13	D12	D11	D10	D9	D8	D7	D6	D5	D4	D3	D2	D1	D0
0	0	0	0	0	0	0	0	Res	Res	Res	Res	XTLP	COS2	COS1	COS0

Res = Reserved Bit. To ensure future compatibility, reserved bits should be set to “0” when written and ignored when read. This register is forced to its default only when power is first applied to the AD1803.

XTLP

Crystal Oscillator Low Power Mode Enable. Depending on board design and crystal used, this bit may be set to 1 to engage a crystal oscillator low power mode which saves up to 0.7 mA. This mode reduces the amount of energy that an AD1803 will provide to keep a crystal oscillating, but otherwise has no effect on AD1803 behavior. If a clock is driven onto the XTALI pin from an external source, rather than generated by a crystal connected between the XTALI and XTALO pins, the optimal setting for this bit is 1, although with only a slight power benefit.

0 = Normal Power Mode (default).

1 = Low Power Mode.

COS[2:0]

CLK_OUT Pin Drive Strength Select. This bit may be used to reduce EM emissions, or three-state the CLK_OUT pin. 000 = 0% of Full Drive Strength (Pad Three-States).

001 = 13% of Full Drive Strength.

010 = 25% of Full Drive Strength.

011 = 38% of Full Drive Strength.

100 = 63% of Full Drive Strength.

101 = 75% of Full Drive Strength.

110 = 88% of Full Drive Strength.

111 = 100% of Full Drive Strength (default).

Monitor Output Control

Default = 0x4000

Address 0x60 Bank 2

D15	D14	D13	D12	D11	D10	D9	D8	D7	D6	D5	D4	D3	D2	D1	D0
MMD1	MMD0	MDM	MDL4	MDL3	MDL2	MDL1	MDL0	Res	Res	MAM	MAL4	MAL3	MAL2	MAL1	MAL0

Res = Reserved Bit. To ensure future compatibility, reserved bits should be set to “0” when written and ignored when read.

MMD[1:0]

Monitor Output Mode. The AD1803’s monitor output provides a programmable mix of the ADC and DAC signals passing through the AD1803’s codec. Pin 11 serves as the monitor output providing Bit GPMON in Register 0x5E is set to 1. Otherwise, Pin 11 serves its default role as a GPIO (General Purpose IO) pin. When the monitor output is enabled (powered up) using these bits (MDM[1:0]), the monitor output will be in the form of digital Σ - Δ modulator bit stream with a maximum edge rate (carrier) of 512 kHz. One of two different Σ - Δ modulator types may be activated: Either a first order which generates 6 dB more signal swing than the other choice but has more inband noise and idle tones, or a third order which has half the signal swing but significantly superior inband noise and negligible idle tones. To extract the signal from the Σ - Δ modulator noise, it is recommended that the monitor output be filtered by connecting Pin 11 to a 1 k Ω resistor in series with a parallel 4.7 k Ω resistor and 100 nF capacitor combination which is then tied to digital ground (DVDD pin). This filter, with the output taken from the middle node, has a 1500 Hz corner to filter out high-frequency Σ - Δ noise, and generates an approximate 1 V p-p output when using a 5 V digital supply with the monitor output configured as a First Order (MMD[1:0] set to 10) if the filter output load is greater than or equal to 20 k Ω . Other filter networks may also be used, perhaps to save power or increase effective output signal swing, but for long term reliability, care must be taken to ensure that the monitor output never sources more than 5 mA. The recommended filter dissipates approximately 1 mA.

00 = Reserved.

AD1803

01 = Monitor Output Powered Down and driven LOW (default).
 10 = Monitor Enabled, First Order Σ - Δ Output, Signal Swing: 0% to 100% ones (best signal amplitude).
 11 = Monitor Enabled, Third Order Σ - Δ Output, Signal Swing: 25% to 75% ones (best signal SNR post filter).

MDM Monitor Output DAC Mix Mute. If both ADC and DAC mix are muted, the Monitor output should probably be powered down (MDM[1:0] set to 10) to achieve a quieter mute.
 0 = DAC Mix Level Determined by Bits MDL[4:0] (default).
 1 = DAC Mix Is Muted.

MDL[4:0] Monitor Output DAC Mix Level. Unless muted by bit MDM in this register, these bits control the amount of DAC signal which will be mixed into the Monitor output. Representation is two's-complement with a least significant bit weighting of 3 dB, and a permissible range of +45 dB to -18 dB. If the AD1803's analog codec is in use (ACSEL set to 0), the DAC signal mixed is taken before this attenuation is applied. In either case, the DAC signal mixed is always taken before the mute bit DAM in Register 0x46 is applied.
 01111 = +45 dB.
 00000 = 0 dB (default).
 11010 = -18 dB.

MAM Monitor Output ADC Mix Mute. If both ADC and DAC mix are muted, the Monitor output should probably be powered down (MAM[1:0] set to 10) to achieve a quieter mute.
 0 = ADC Mix Level Determined by Bits MAL[4:0] (default).
 1 = ADC Mix Is Muted.

MAL[4:0] Monitor Output ADC Mix Level. Unless muted by bit MAM in this register, these bits control the amount of ADC signal which will be mixed into the Monitor output. Representation is two's-complement with a least significant bit weighting of 3 dB, and a permissible range of +45 dB to -18 dB. The ADC signal mixed is always taken after the gain specified by Bits DAL[4:0] in Register 0x46 is applied, but before the mute bit ADM in Register 0x46 is applied.
 01111 = +45 dB.
 00000 = 0 dB (default).
 11010 = -18 dB.

Version ID Default = 0x0002 Address 0x7A

D15	D14	D13	D12	D11	D10	D9	D8	D7	D6	D5	D4	D3	D2	D1	D0
0	0	0	0	0	0	0	0	VER7	VER6	VER5	VER4	VER3	VER2	VER1	VER0

VER[7:0] AD1803 Version. Writes to this register have no effect. The latest version of the AD1803 is 0x0002.

Vendor ID1 Default = 0x4144 Address 0x7C

D15	D14	D13	D12	D11	D10	D9	D8	D7	D6	D5	D4	D3	D2	D1	D0
0	1	0	0	0	0	0	1	0	1	0	0	0	1	0	0

Vendor ID2 Default = 0x5380 Address 0x7E

D15	D14	D13	D12	D11	D10	D9	D8	D7	D6	D5	D4	D3	D2	D1	D0
0	1	0	1	0	0	1	1	1	0	0	0	0	0	0	0

Writes to Registers 0x7C and 0x7E have no effect. When read, 0x7C and 0x7E return 0x4144 and 0x5380 which, taken together, map to ADS in ASCII followed by 0x80. ADS is registered in the AC'97 specification to identify Analog Devices as the vendor, and the final byte of 0x80 is used to identify the AD1803 (vendor-selected value).

APPLICATION CIRCUIT

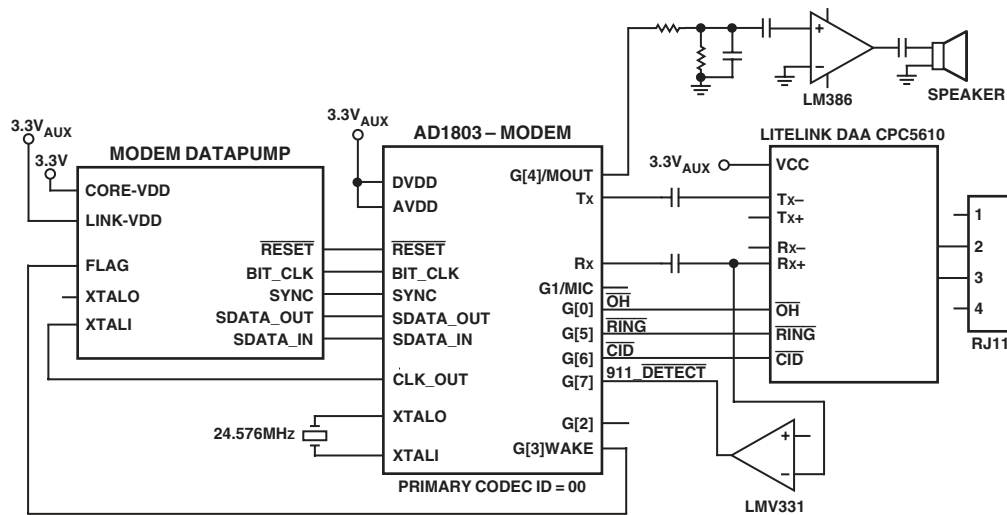

Figure 12. PC/Embedded Modem

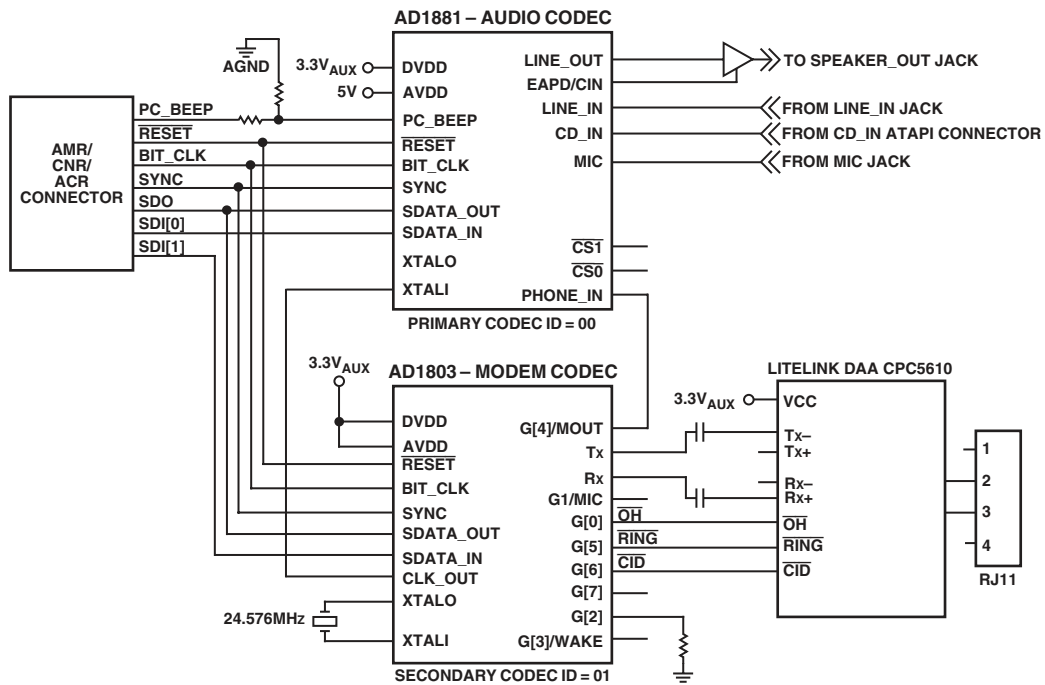

Figure 13. Audio Modem Riser

AD1803

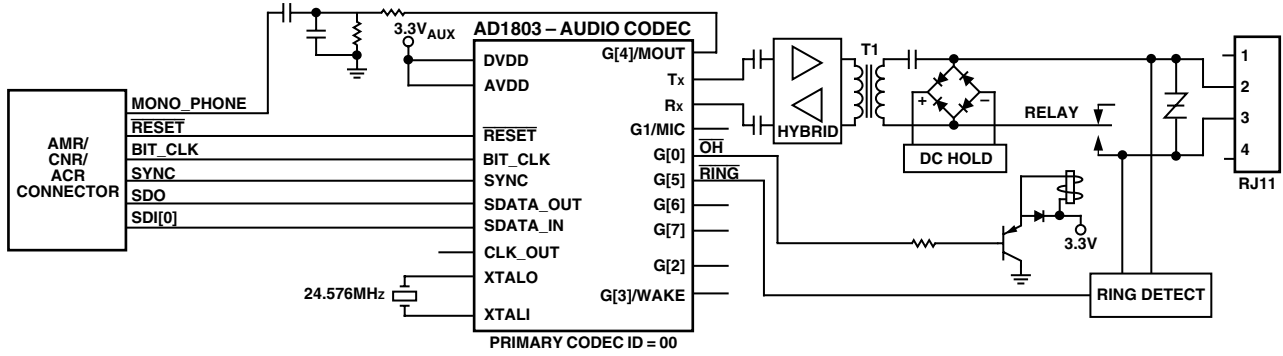

Figure 14. Modem Riser with Discrete DAA

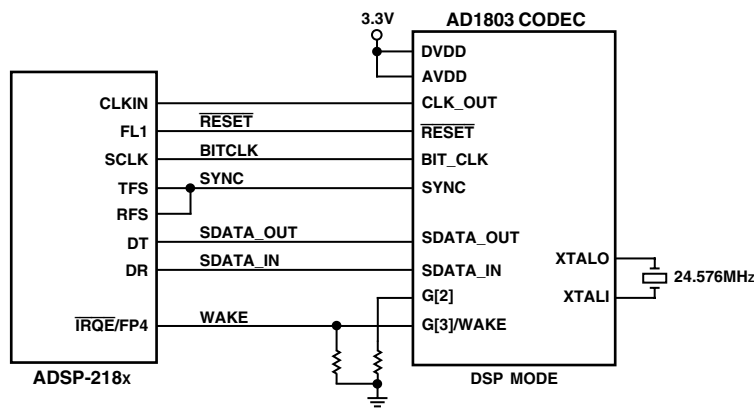

Figure 15. Interfacing AD1803 to ADSP-218x DSP

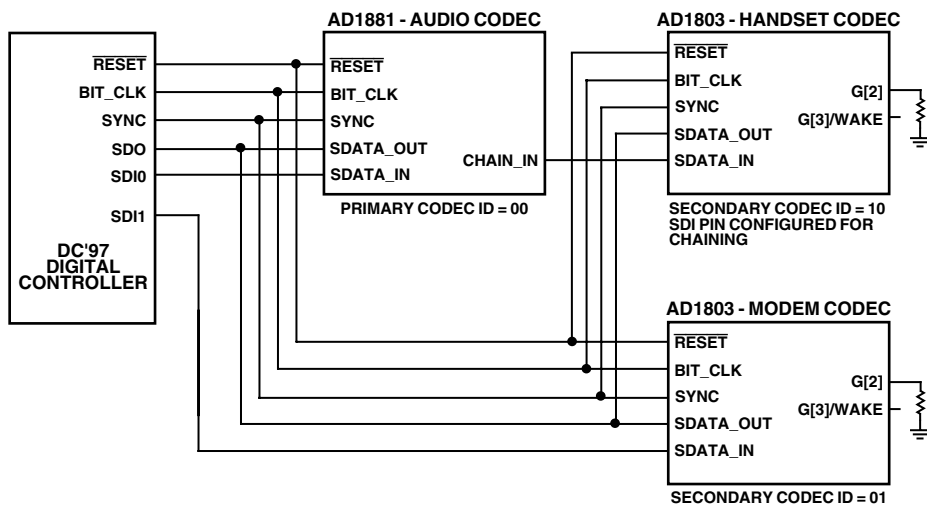

Figure 16. Codec Chaining Allows Several ADI AC'97 CODECs to be Connected to One AC-Link Controller Port

TYPICAL INITIALIZATION SEQUENCE IMMEDIATELY AFTER FIRST RESET

Step 1: Write to Register 0x5C (Configuration Register 1).

Bits 14:13—BNK[1:0] (Register Bank Select): these bits should be set to “01” in preparation of Step 2 below.

Bit 12—R34PM (AD1803 $\overline{\text{RESET}}$ Power Mode Select): if it will be desired to have the AD1803 drive a clock out on the CLKOUT pin while $\overline{\text{RESET}}$ is asserted, this bit must be changed from its default setting of “0” to “1.” Otherwise, the AD1803 will be completely powered down whenever $\overline{\text{RESET}}$ is asserted ($\overline{\text{RESET}}$ pin driven LOW).

Bit 11:10—XTAL[1:0] (Crystal Identification): if the clock presented on pin XTALI is not 24.576 MHz, the default setting of these bits must be changed to identify the actual XTALI frequency provided.

Bit 9—ACSEL (Analog Codec Select): while this bit may be updated at any time, and even while the codec is enabled, it is somewhat more sensible to set this bit prior to enabling the codec. This bit selects an analog codec will be used in conjunction with the digital codec within the AD1803. When set to “0,” which is the default, the analog codec within the AD1803 will be used.

Bit 8—ADCAL (ADC Calibration): until the codec is enabled, writes to this bit have little purpose.

Bit 7—CLKED (CLK_OUT Enable While $\overline{\text{RESET}}$ Is Deasserted): immediately after $\overline{\text{RESET}}$ is deasserted ($\overline{\text{RESET}}$ pin driven HIGH) this bit is always RESET to a “1.” This enables the CLK_OUT pin to provide a buffered version of the clock received on XTALI pin following every deassertion of $\overline{\text{RESET}}$. Therefore, to stop this clock LOW and save power, this bit must be set to “0” after every deassertion of $\overline{\text{RESET}}$. Stopping CLK_OUT will save about 1.5 mA plus any addition current saved by not driving whatever board load which might be present. Note that CLK_OUT may also be permanently three-stated using Bits COS[2:0] in register 0x64 bank 1.

Bit 6—CLKEA (CLK_OUT Enable While $\overline{\text{RESET}}$ Is Asserted): this bit must be changed from its default of “0” to “1” if it is desired to have the CLK_OUT pin provide a clock output while the AD1803 is $\overline{\text{RESET}}$ ($\overline{\text{RESET}}$ pin driven LOW). Note that the behavior selected by the state of this bit may be overridden by Bit R34PM.

Step 2: Write to Register 0x64 bank 1 (Clock Pin Control Register).

Bit 3—XTLP (Crystal Low Power Mode Enable): depending on board design and crystal used, this bit may be set to “1” to engage a crystal oscillator low power mode which saves up to 0.7 mA. This mode reduces the amount of energy that an AD1803 will provide to keep a crystal oscillating, but otherwise has no effect on AD1803 behavior. If a clock is driven onto the XTALI pin from an external source rather than generated by a crystal connected between the XTALI and XTALO pins, the optimal setting for this bit is “1,” although with only a slight power benefit.

Bits 2:0—COS[2:0] (CLKOUT Pin Drive Strength Select): These bits should be set to select the optimal output driver strength for pin CLKOUT to soften edges and reduce EMI emissions.

Step 3: Write to Register 0x5E (Configuration Register 2).

Bit 14—GPWAK (GPIO[3]/Wake Signal Select): if an interrupt/wake output signal is desired, this bit must be changed from its default setting of “0” to “1.” This enables Pin 12 to serve this role rather than a default role as a general-purpose IO pin. When serving as an interrupt/wake flag, Pin 12 will be driven high whenever a qualifying event has occurred.

Bit 13—GPMON (GPIO[4]/Monitor Output Select): if the monitor output feature will be used, this bit must be changed from its default setting of “0” to “1.” This enables Pin 11 to serve this role rather than a default role as a general-purpose IO pin. When serving as a monitor output, Pin 11 outputs a Σ - Δ bit stream consisting of a selectable mix of the signals present on the ADC and DAC channels.

Bit 12—GPMIC (GPI[1]/MIC Input Select): if a second selectable ADC input source is desired, the setting of this bit must be changed from its default of “0” to “1.” This switches the role of Pin 15 from a general-purpose input flag to an analog mic input.

Bits 11, 10, 9, 7, 6:—SPCHN, SPGBP, SPDSS, and SPDL[1:0]: these bits affect the operation of the AD1803 only if in an AC⁹⁷ serial interface mode.

Bit 8—SPISO (Serial Port Isolate): see the TYPICAL POWER-DOWN SEQUENCE section for further details.

Step 4: Read Register 0x60 Bank 1 (GPIO Initial State Register).

As $\overline{\text{RESET}}$ is deasserted ($\overline{\text{RESET}}$ pin driven HIGH), the first time after power is applied to the AD1803, the states of all general-purpose IO (GPIO) pins are sampled and stored in this register. While the sampled states of GPIO Pins 2 and 3 are used by the AD1803 to determine serial interface mode, all remaining GPIO pins are available for use, if beneficial, as identification bits to a host software.

Step 5: Write to Registers 0x4C through 0x54 (GPIO Control Registers).

These registers determine the behavior of the AD1803’s GPIO (general-purpose IO) pins. After power is first applied to the AD1803, all GPIO pins default as inputs but with weak (~100 μ A) pull-up devices within the AD1803 enabled to pull any floated GPIO pins HIGH. As needed, these pins may be reconfigured to serve as interrupt sources, active high or low, sticky or unsticky, or general-purpose outputs with open-drain or CMOS drivers. The weak pull-up device may also be disabled to save power. The settings of these registers, like most registers within the AD1803, are unaffected by a $\overline{\text{RESET}}$ and are set to their defaults only when power is first applied to the AD1803. The most sensible order is 0x4E, 0x4C, 0x50, 0x54, and finally 0x52.

Step 6: Write to Registers 0x40 and 0x46 (Sample Rate and Level Control).

These registers determine the codec sample rate and channel attenuation levels. While these register may be updated at any time, including while the codec is enabled, it is somewhat more sensible to establish desired settings prior to enabling the codec.

AD1803

TYPICAL CODEC POWER-UP SEQUENCE

Step 7: Write to Register 0x3E (Status and Control Register).

Bit 11—DPDN (DAC Power-Down): this bit must be set to “0” for the AD1803’s DAC codec channel to be enabled. While this bit is set to “1” (default), all DAC resources within the AD1803 will be powered down, and all data words sent to the AD1803 over the serial interface will be ignored. When this bit is set to “0,” the digital DAC resources within the AD1803 will be powered up, but the analog DAC resources within the AD1803 will be powered up only if both: 1) the AD1803’s voltage reference is powered up (Bit VPDN in this register set to “0”), and 2) the AD1803’s analog codec is selected as the partner to the AD1803’s digital codec (Bit ACSEL in register 0x5C set to “0”).

Bit 10—APDN (ADC Power-Down): This bit should be set to “0” for the AD1803’s ADC codec channel to be enabled. While this bit is set to “1” (default), all ADC resources within the AD1803 will be powered down, and all data words sent out of AD1803 over the serial interface will be set to midscale (zero). When this bit is set to “0,” the digital ADC resources within the AD1803 will be powered up, but the analog ADC resources within the AD1803 will be powered up only if both: 1) the AD1803’s voltage reference is powered up (Bit VPDN in this register set to “0”), and 2) the AD1803’s analog codec, is selected as the partner to the AD1803’s digital codec (Bit ACSEL in Register 0x5C set to “0”). Each time the AD1803’s analog codec is powered up, an ADC calibration is automatically initiated. This calibration requires approximately 104 sample periods (defined by Register 0x40), but can’t be started until after the AD1803’s voltage reference is powered up (by setting Bit VPDN below to “0”), which itself requires about 48 ms. Bit VSTA in this register may be polled first to determine if the voltage reference is powered up, and then Bit ADCAL in register 0x5C may be polled to determine if calibration is completed. During calibration, codec sample rate (Register 0x40), and ADC source and gain level (Bits Rx/Mic, ADG20, and ADL[3:0] in Register 0x46) must not be changed.

Bit 9—VPDN (Voltage Reference Power-Down): if the AD1803’s analog codec will be used, this bit must be set to “0” to power up the AD1803’s voltage reference. Until the voltage reference is powered up, the AD1803’s analog codec channels will ignore the setting of Bits APDN and DPDN and remain powered down. Once this bit is set to “0,” approximately 48 ms are necessary to power up the voltage reference. Bit VSTA in this register may be polled to monitor the status of the voltage reference.

Bit 8—GPDN (General-Purpose IO Pin Power-Down): contrary to this bit’s name, its setting has no effect on AD1803 operation when configured in DSP mode. When the AD1803 is configured in an AC’97 mode, this bit must be set to “0” for Slot 12 to access GPIO pins.

Bit 3—DSTA (DAC Status): this bit exists solely for AC’97 compatibility. Its purpose is to provide a handshake for DAC power-up/-down status changes initiated by writes to Bit DPDN. However, since the AD1803 will respond to a write of Bit DPDN prior to it being possible to read this bit in a following serial interface frame, it’s pointless to poll this status bit.

Bit 2—DSTA (DAC Status): this bit exists solely for AC’97 compatibility. Its purpose is to provide a handshake for ADC power-up/-down status changes initiated by writes to Bit APDN. However, since the AD1803 will respond to a write of Bit APDN

prior to it being possible to read this bit in a following serial interface frame, it’s pointless to poll this status bit.

Bit 1—VSTA (Voltage Reference Status): this bit may be polled to monitor the status of the voltage reference. When read as a “0,” the voltage reference is either powered down or in the process of powering up. When read as a “1,” the voltage reference is either powered up or in the process of powering down. Approximately 48 ms after VPDN is set to a “0,” this bit will transition from a “0” to a “1” indicating that the voltage reference is powered up.

Bit 0—GSTA (GPIO pin status): this bit exists solely for AC’97 compatibility. Its purpose is to provide a handshake for power-up/-down status changes initiated by writes to Bit GPDN. However, since the AD1803 will respond to a write of Bit GPDN prior to it being possible to read this bit in a following serial interface frame, it’s pointless to poll this status bit.

Step 8: Write to Register 0x5C (Configuration Register 1).

The purpose of this write is to change the register bank selection in preparation for Step 9 following. The value written to Register 0x5C at this time should be identical to the value from Step 12, except with Bits 14:13 (BNK[1:0]) set to “10.”

Step 9: Write to Register 0x60 bank 2 (Monitor Output Control)

Writes to this register have no purpose unless a pin has been assigned to serve as a monitor output (see Step 3 write to Bit GPMON in Register 5E). This register may be written to power up and down the monitor channel, select the mix of ADC and DAC channels delivered to the monitor output, and select the order of the Σ - Δ monitor output bit stream.

TYPICAL CODEC POWER-DOWN SEQUENCE

There are two ways to power down the codec. The first way is to simply assert **RESET** (drive **RESET** pin LOW). This clears register 0x3E to its initial power-up default which will power down the AD1803’s ADC, DAC, and voltage reference. A second and more graceful method is outlined below:

Step 1: Write to Register 0x3E (Status and Control Register).

Bit 11—DPDN (DAC Power-Down): this bit must be set to “1” to power down the AD1803’s DAC channel.

Bit 10—APDN (ADC Power-Down): this bit must be set to “1” to power down the AD1803’s ADC channel.

Bit 9—VPDN (Voltage Reference Power-Down): this bit may be set to “1” to power down the AD1803’s voltage reference and save approximately 200 μ A, but it may be desirable to leave the voltage reference powered up. Leaving it powered up will save about 48 ms from a future codec power-up sequence, and will avoid potential “clicks” caused by the DAC output tracking the voltage reference as it falls to 0 volts when powered down, and rises to \sim 1.25 volts when powered back up.

Bit 8—GPDN (General-Purpose IO Power-Down): this bit may be set to any value since it has no effect on AD1803 operation when in DSP mode.

Bit 1—VSTA (Voltage Reference Status): this bit may be polled to determine the status of the AD1803’s voltage reference. When read as a “0,” the voltage reference is either powered down or in the process of powering up. When read as a “1,” the voltage reference is either powered up or in the process of powering down. Within 0.8 ms after VPDN is set to a “0,” this bit will transition

from a “1” to a “0” indicating that the voltage reference is completely powered down. If a clock driven onto the AD1803’s XTALI pin, and it is desired to stop this clock for additional system power savings, this clock must not be stopped until after this bit falls to a “0.”

TYPICAL CHIP POWER-DOWN SEQUENCE

Once the codec is powered down to the level desired, no additional power may be saved unless the AD1803 receives a $\overline{\text{RESET}}$, ignoring power potentially saved by stopping the clock on the CLKOUT pin or disabling GPIO pin drivers which have resistive loads. When a $\overline{\text{RESET}}$ is received by the AD1803, the serial interface will automatically be powered down, leaving the AD1803’s internal clock generation and distribution circuitry as the final significant power consumer to be addressed. If Bit R34PM in Register 0x5C is set to a “0” before $\overline{\text{RESET}}$ is asserted,

this clock circuitry will be powered down as well when $\overline{\text{RESET}}$ asserted, with the consequence that wake-up on ring and ability to source a clock on the CLKOUT pin during $\overline{\text{RESET}}$ will be lost. This leaves silicon leakage current, typically less than 100 μA , plus inadvertent serial interface loading as the final power drains. Inadvertent serial interface loading may be due to either the AD1803 receiving intermediate or switching logic levels on its BIT_CLK, SYNC or SDATA_OUT input pins, or the presence of resistive loads to a potential other than DGND (AD1803 digital ground) on the SDATA_IN or BIT_CLK output pins. This inadvertent serial interface loading can be eliminated if Bit SPIISO (Serial Port Isolate) in Register 0x5E is set to “1” before the AD1803 receives a $\overline{\text{RESET}}$, with the consequence that output BIT_CLK will be driven LOW weakly (<200 μA drive current) whenever $\overline{\text{RESET}}$ is asserted.

OUTLINE DIMENSIONS
 Dimensions shown in inches and (mm).

**24-Lead TSSOP
 (RU-24)**

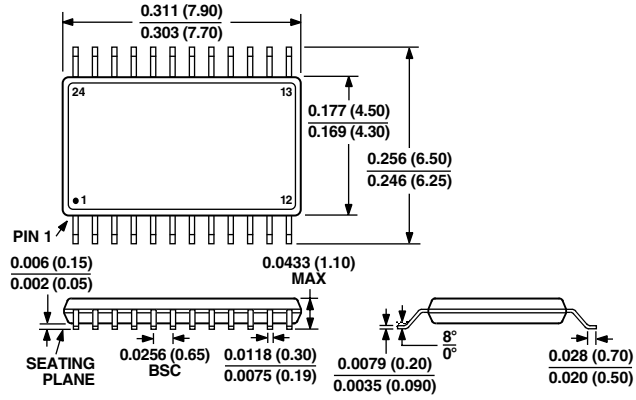

C02562-0-7/01(0)

PRINTED IN U.S.A.