

IE-PCB-SPO-P-180V-THR

Weidmüller Interface GmbH & Co. KG

Klingenbergstraße 26

D-32758 Detmold

Germany

www.weidmueller.com



Single Pair Ethernet PCB sockets

Single pair Ethernet is a technology that only requires one pair of wires to transmit data and power.

The resulting benefits will make SPE the preferred network at the field level and beyond.

Advantages of Single Pair Ethernet:

- Consistent: Single Pair Ethernet enables uniform Ethernet-based communication from the sensor to the cloud
- Future-proof: key technology for Industry 4.0 and IIoT
- Flexible: ranges of up to 1000 m and transmission properties of up to 1 Gbps enable use across applications
- Innovative: lighter, less space required, and reduced installation effort

General ordering data

Version	PCB plug-in connector, male header, SPE (Single Pair Ethernet), Clip-on flange, THT/THR solder connection, 1.80 mm, Number of poles: 2, 180°, Solder pin length (l): 2.1 mm, Ni/Au, silver, Tape
Order No.	2795170000
Type	IE-PCB-SPO-P-180V-THR
GTIN (EAN)	4064675 119265
Qty.	100 pc(s).
Packaging	Tape

IE-PCB-SP0-P-180V-THR**Weidmüller Interface GmbH & Co. KG**

Klingenbergstraße 26

D-32758 Detmold

Germany

www.weidmueller.com

Technical data**Dimensions and weights**

Depth	9.3 mm	Depth (inches)	0.366 inch
Height	9 mm	Height (inches)	0.354 inch
Width	5 mm	Width (inches)	0.197 inch
Net weight	4.03 g		

Temperatures

Operating temperature	-40 °C...85 °C
-----------------------	----------------

System specifications

LED	No	Mounting onto the PCB	THT/THR solder connection
Number of poles	2	Outgoing elbow	180°
Performance-Category	10/100 MBit/s, 1000 MBit/s	Pitch in mm (P)	1.8 mm
Plugging cycles	750	Product family	Industrial Ethernet
Protection degree	IP20	Shielding	Yes
Side termination, characteristic	Clip-on flange	Solder pin dimensions	Octagonal
Solder pin length (l)	2.1 mm	Soldering process	Reflow soldering, Manual soldering, Wave soldering
Tolerance of solder pin position	± 0.1 mm	Transmission rate	10/100 MBit/s, 1000 MBit/s
Type of connection	Solder connection, Male contact		

Electrical properties

Dielectric strength, contact / contact	1000 V DC	Dielectric strength, contact / shield	2250 V DC
Insulation strength	≥ 500 MΩ	PoE / PoE+	PoDL acc. to IEEE 802.3bu / cg
Rated current	4 A	Rated voltage	72 V

Standards

Connector standard	IEC 63171-2
--------------------	-------------

Material data

Insulating material	LCP	Colour	silver
Colour chart (similar)	RAL 7001	Insulation strength	≥ 500 MΩ
Moisture Level (MSL)	1	UL 94 flammability rating	V-0
Contact material	Cu	Contact surface	Ni/Au
Operating temperature, min.	-40 °C	Operating temperature, max.	85 °C

Packing

Packaging	Tape	VPE length	330 mm
VPE width	330 mm	VPE height	29 mm

IE-PCB-SPO-P-180V-THR

Weidmüller Interface GmbH & Co. KG
Klingenbergstraße 26
D-32758 Detmold
Germany

www.weidmueller.com

Technical data

Classifications

ETIM 6.0	EC002637	ETIM 7.0	EC002637
ETIM 8.0	EC002637	ECLASS 9.0	27-44-04-02
ECLASS 9.1	27-44-04-02	ECLASS 10.0	27-44-04-02
ECLASS 11.0	27-46-02-01		

Approvals

ROHS	Conform
------	---------

Downloads

Engineering Data	CAD data – STEP
Technical Documentation	IE-PCB-SPO-P-180V-THR
Catalogues	Catalogues in PDF-format

IE-PCB-SP0-P-180V-THR

Weidmüller Interface GmbH & Co. KG
 Klingenbergstraße 26
 D-32758 Detmold
 Germany

www.weidmueller.com

Drawings

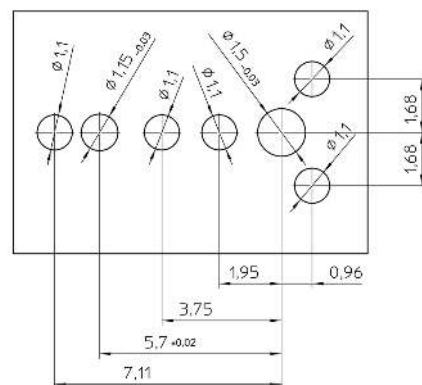
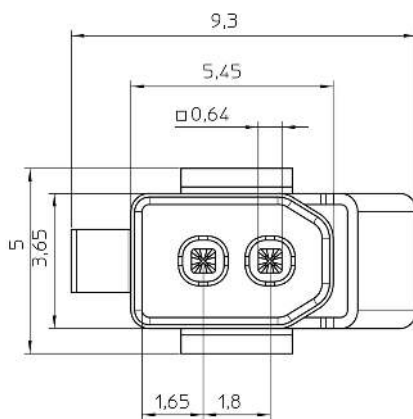
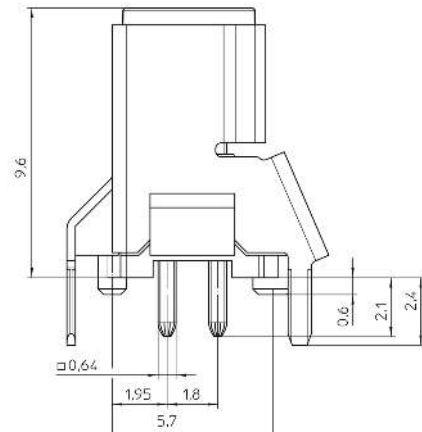
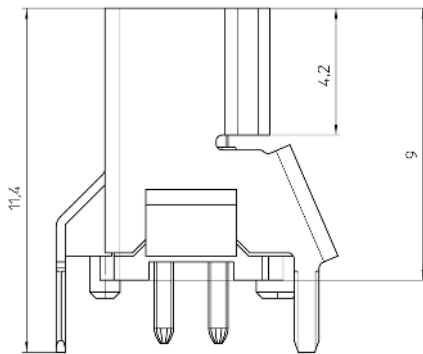

IE-PCB-SP0-P-180V-THR

Weidmüller Interface GmbH & Co. KG
Klingenbergstraße 26
D-32758 Detmold
Germany

www.weidmueller.com

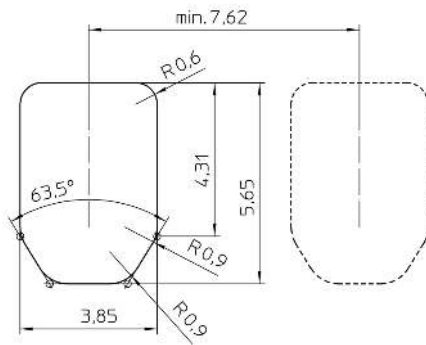
Drawings

2795170000 IE-PCB-SP0-P-180V-THR

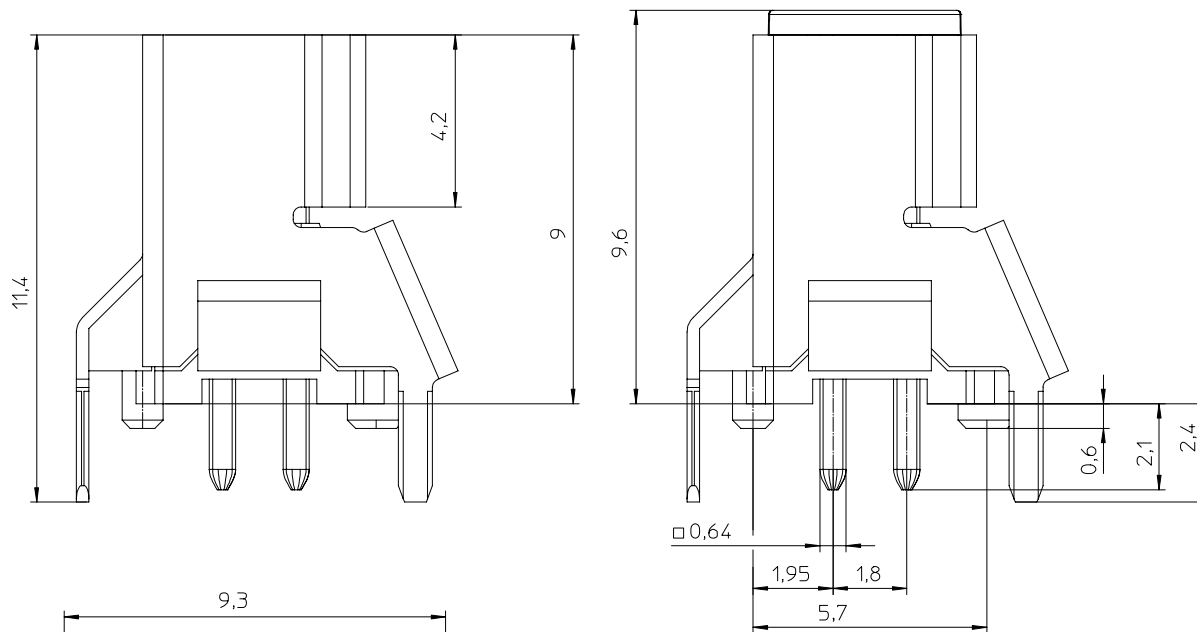

Pin assignment

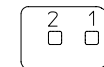

Pair	Contacts	Data
1	1	RX/TX+
	2	RX/TX-

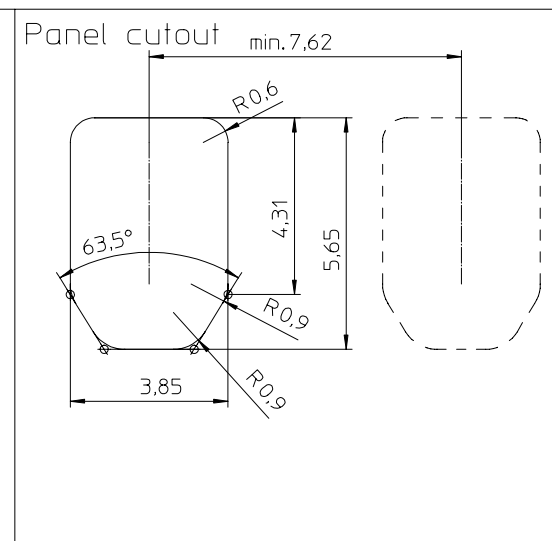
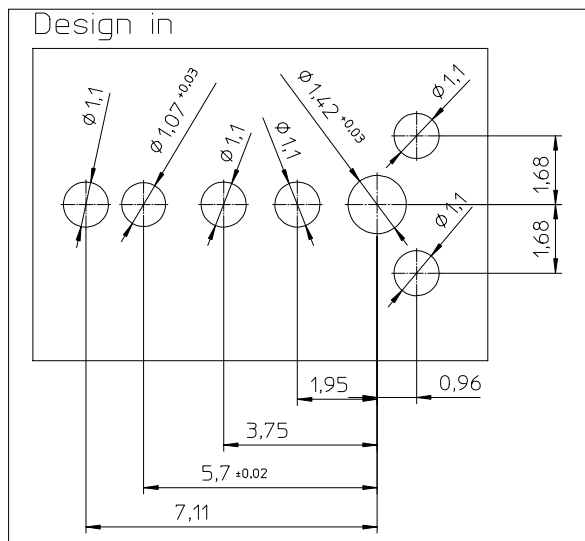
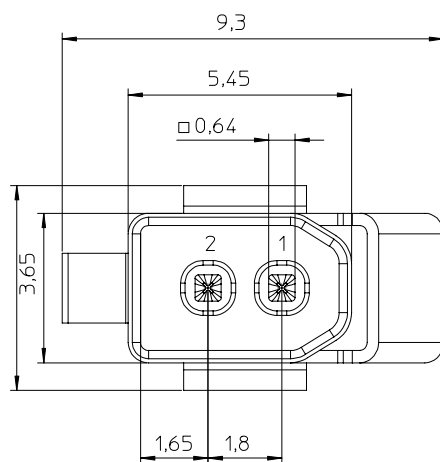

2795170000 IE-PCB-SP0-P-180V-THR

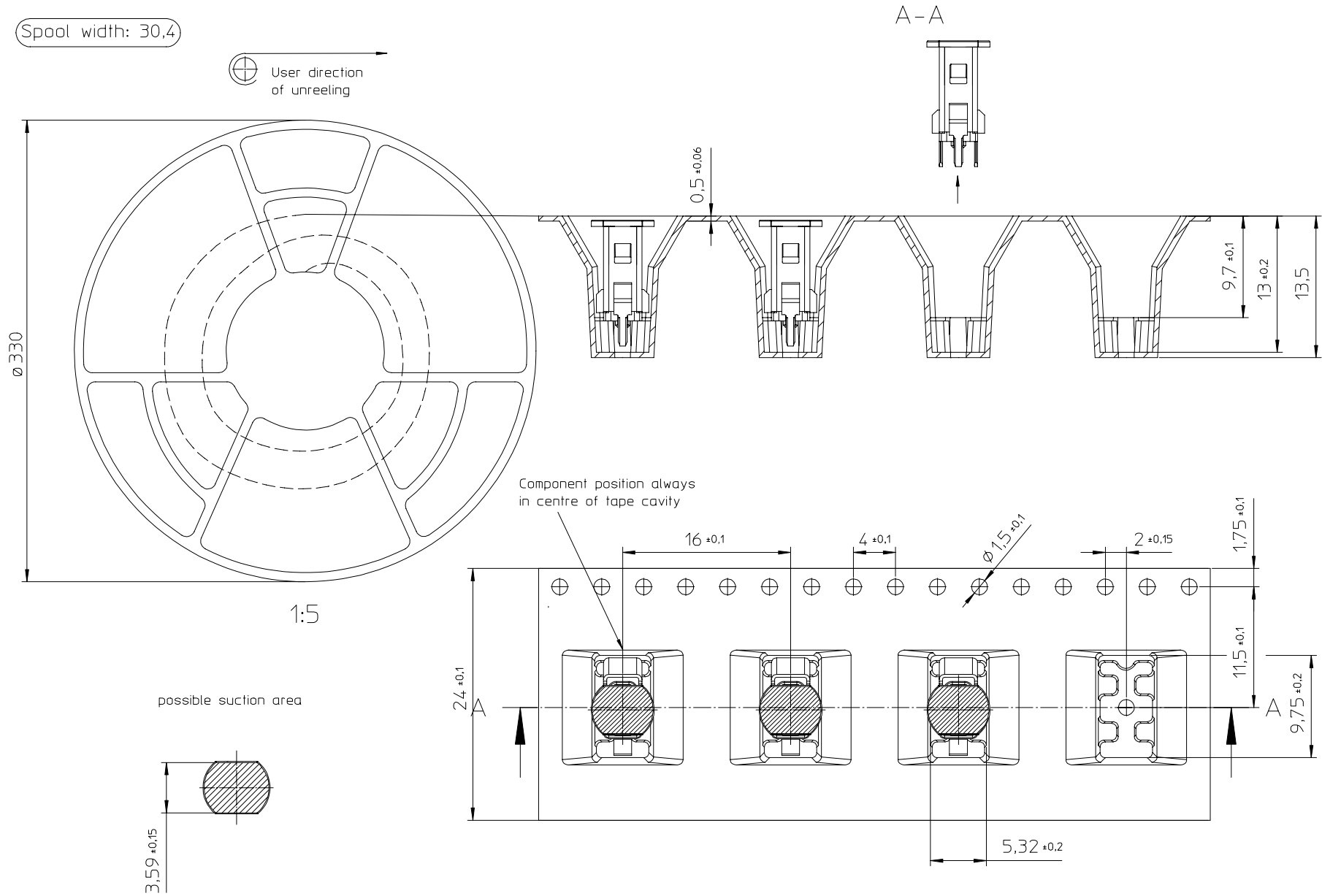

Recommended wave soldering profiles

Weidmüller Interface GmbH & Co. KG
 Klingenbergstraße 16
 D-32758 Detmold
 Germany
 Fon: +49 5231 14-0
 Fax: +49 5231 14-292083
 www.weidmueller.com

Single Wave:

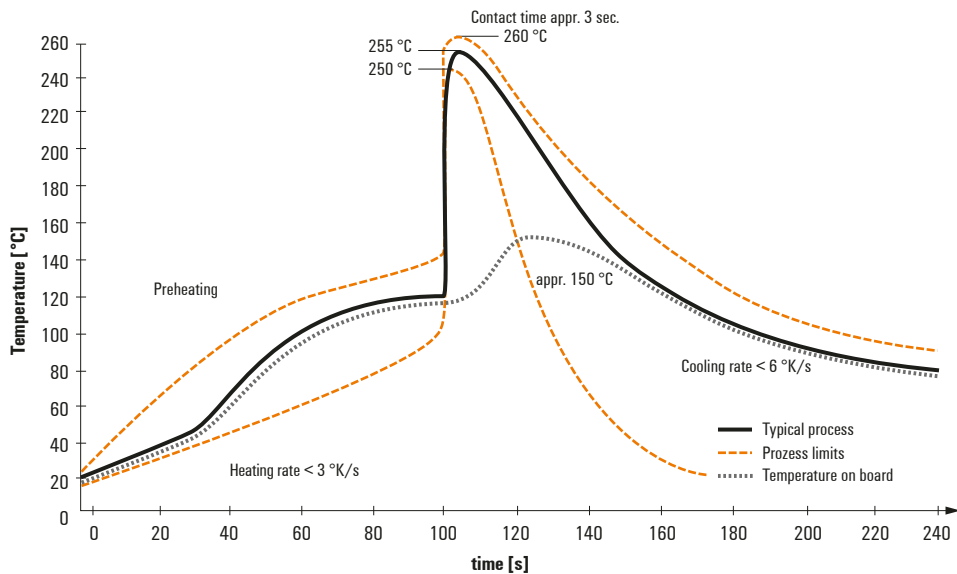

Double Wave:

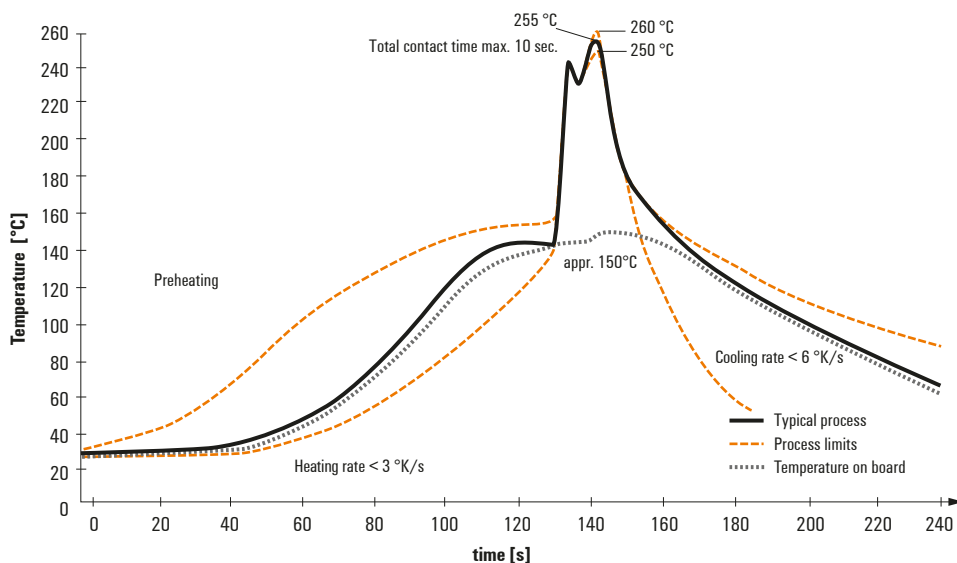

Wave soldering profiles

Wired connection elements should be processed in accordance with the DIN EN 61760-1 standard. We have included two recommendations for practical wave soldering profiles, with which Weidmüller PCB terminals and connectors are qualified.

When choosing a suitable profile for your application, the following factors also need to be considered:

- PCB thickness
- Proportion of Cu in the layers
- Single/double-sided assembly
- Product range
- Heating and cooling rates

The single and double wave profiles each indicate the recommended operating range, including the maximum soldering temperature of 260°C. In practice, the maximum soldering temperature is quite often well below the above maximum profile.

Recommended reflow soldering profile

Weidmüller Interface GmbH & Co. KG
 Klingenbergstraße 16
 D-32758 Detmold
 Germany
 Fon: +49 5231 14-0
 Fax: +49 5231 14-292083
 www.weidmueller.com

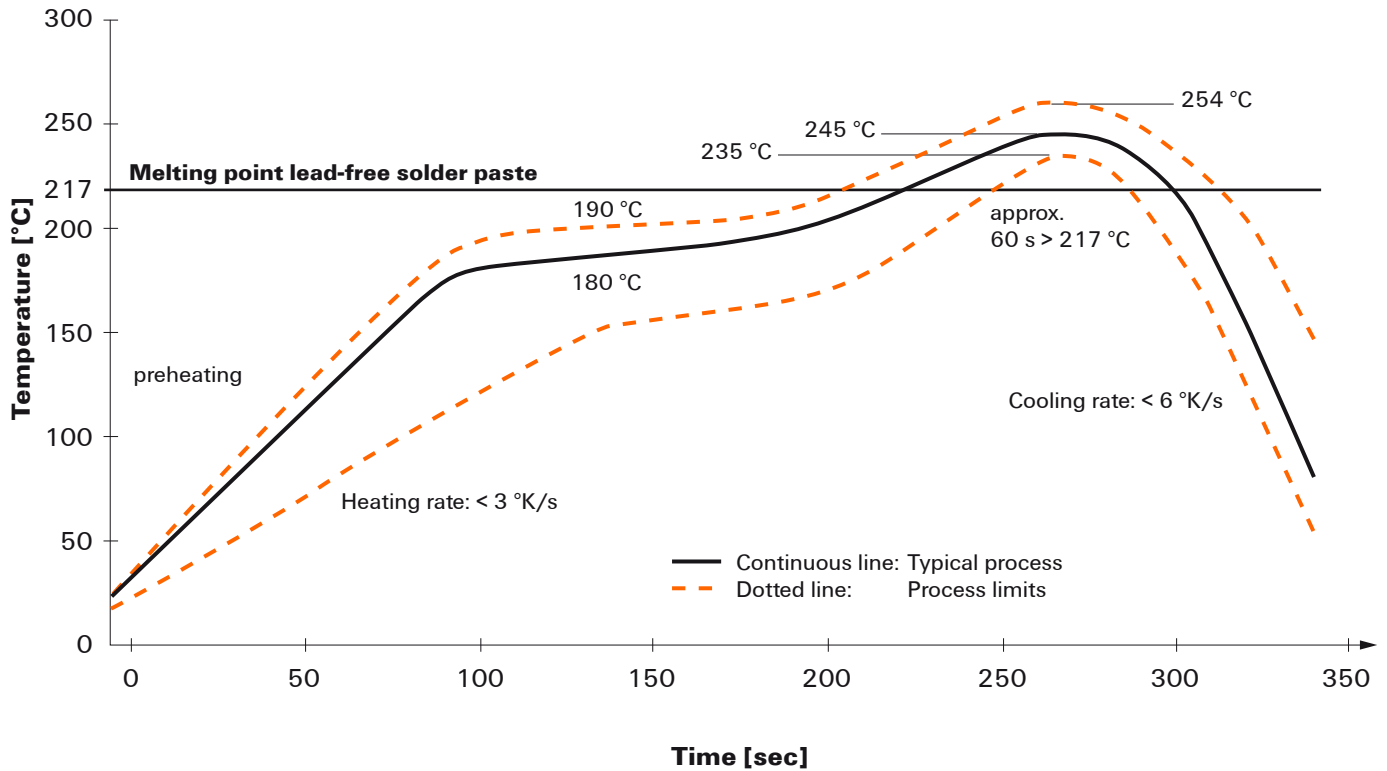

Reflow soldering profile

The perfect soldering profile for SMT Surface Mount Technology is one the most exiting question in SMT production. But there are more than one correct answer: The diagram of temperature-on-time is related to processing features of solder paste and to maximum load of components.

We have to consider the following parameters:

- Time for pre heating
- Maximum temperature
- Time above melting point
- Time for cooling
- Maximum heating rate
- Maximum cooling rate

We recommend a typical solder profile with associated process limits. With preheating components and board are prepared smoothly for the solder phase. Heating rate is typically $\leq +3\text{K/s}$. In parallel the solder paste is ‚activated‘. The time above melting point of 217°C the paste gets liquid and components and boards begin to connect. The maximum temperature of 245°C to 254°C should stay between 10 and 40 seconds. In the cooling phase at $\geq -6\text{K/s}$ solder is cured. Board and components cool down while avoiding cold cracks.