

# Ethernet connector™

## Manual

*All Mikroelektronika's development systems feature a large number of peripheral modules expanding microcontroller's range of application and making the process of program testing easier. In addition to these modules, it is also possible to use numerous additional modules linked to the development system through the I/O port connectors. Some of these additional modules can operate as stand-alone devices without being connected to the microcontroller.*

# Additional Board

 **MikroElektronika**

SOFTWARE AND HARDWARE SOLUTIONS FOR EMBEDDED WORLD ...making it simple

## Ethernet Connector

The Ethernet Connector is a simple, yet effective solution for adding reliable connection capability to your ethernet-supporting device. Board contains 10/100 Base-T RJ45 connector and surrounding electronics for stable and reliable ethernet operation.

### Key features:

- RJ45 ethernet connector;
- 3.3V DC power supply.

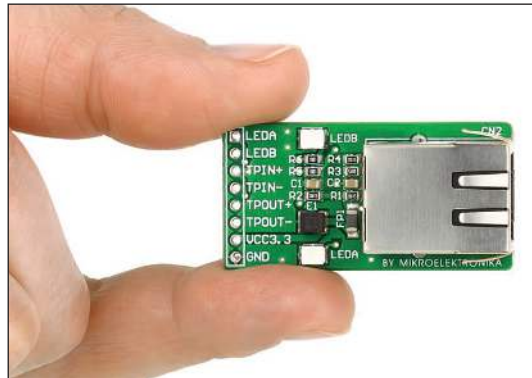

Figure 1: Ethernet connector additional board

### Connection:

The additional board can be connected to a microcontroller that has integrated ethernet controller or any other device that features adequate ethernet controller.

For connection with a device, the additional board uses pads CN1. In order to connect the additional board to ethernet network, it is necessary to plug network cable into ethernet connector CN2.

### Pinout:

Pads pinout:

- LEDA: Signal LED output (indicates receiving data rate);
- LEDB: Signal LED output (indicates transmission data rate);
- TPIN+: Differential Ethernet Receive Plus Signal Input;
- TPIN-: Differential Ethernet Receive Minus Signal Input;
- TPOUT+: Differential Ethernet Transmit Plus Signal Output;
- TPOUT-: Differential Ethernet Transmit Minus Signal Output;
- VCC3.3: 3.3V power supply input; and
- GND: Ground.

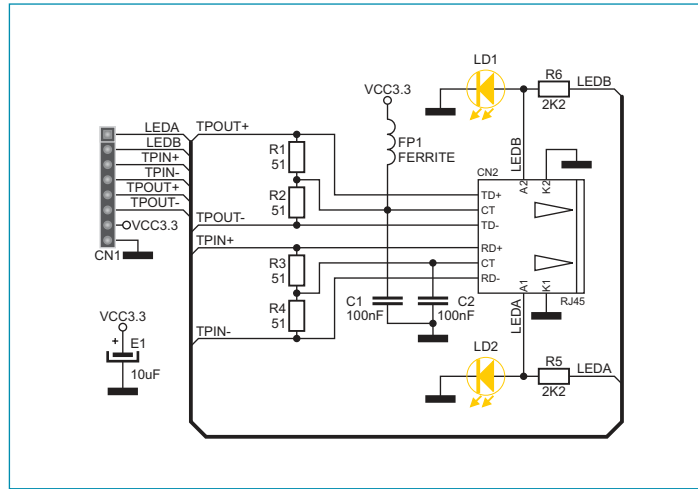

Figure 2: Ethernet Connector connection schematic

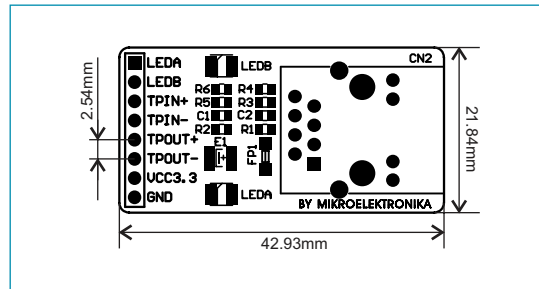

Figure 3: Dimensions of Ethernet Connector



**MikroElektronika**

SOFTWARE AND HARDWARE SOLUTIONS FOR EMBEDDED WORLD ...making it simple

If you want to learn more about our products, please visit our website at [www.mikroe.com](http://www.mikroe.com)

If you are experiencing some problems with any of our products or just need additional information, please place your ticket at [www.mikroe.com/en/support](http://www.mikroe.com/en/support)

If you have any questions, comments or business proposals, do not hesitate to contact us at [office@mikroe.com](mailto:office@mikroe.com)