

BTFC-series TCXO-based 1PPS Time to Frequency Converter Module



D
A
T
A
S
H
E
E
T

Overview

The BTFC Series is a highly integrated time and frequency synchronizing module. This design implementation is dedicated for use in applications which specifically require locking to an incoming 1PPS reference signal. This high precision phase and frequency synchronization solution also integrates “any frequency” clock signal generation and frequency translation. This product can be used to support a high-stability frequency reference for use in wireless systems, IEEE 1588v2, and applications employing a 1PPS frequency source for high precision, long term time and frequency generation.



The BTFC module outputs a 1PPS signal and a digitally synthesized 3.3V LVCMOS clock output at frequencies from 152Hz to 80 MHz. In addition, the module can generate up to 2 additional clean clock outputs at a variety of frequencies from 160MHz to <1KHz. The generated frequency outputs are both phase and frequency locked to the incoming 1PPS reference signal.

Features

- Accepts 1 PPS Reference input
- Locked, Holdover indication
- 1 PPS & NCO Frequency Output
- “Any Frequency” Generation from 152 Hz to 80MHz
- 1PPS Auto-detect
- Automatic entry into holdover
- 3.3VDC Supply Voltage
- 2 Clean low phase noise clock outputs
- Output Frequencies: 10 Hz to 160 MHz
- TCXO Master Clock
- Phase and Frequency locked outputs
- -40°C to 85°C operating temperature range
- OEM SM footprint 21x14 mm
- RoHS Compliant

Figure 1: BTFC Functional Block Diagram

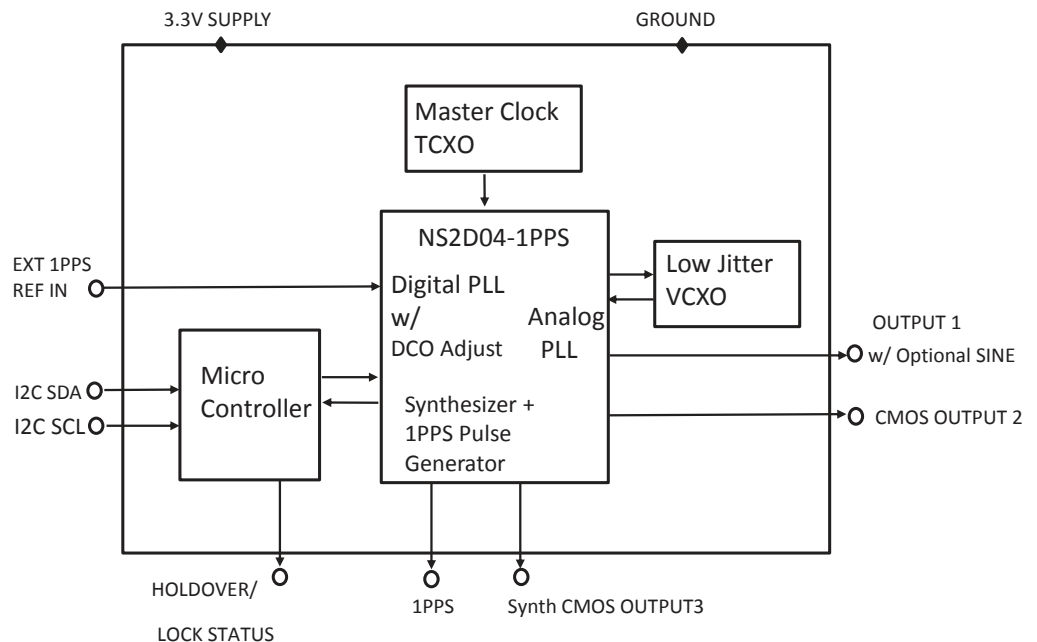

1 INTRODUCTION

The BTFC product series is a small OEM surface mount timing module specifically designed for use in synchronization and timing applications. This module incorporates Connor-Winfield's advanced NS2D04 synchronizing ASIC which integrates a digital phase lock loop system with an analog phase lock loop system and multiple output transmitters to allow the user to discipline an external 1PPS signal and generate multiple output clocks phase locked and aligned to the incoming 1PPS reference.

The digital PLL system design supports low bandwidth settings used for disciplining the incoming 1PPS signal. The DPLL system in the BTFC Series is supported by a master clock which is derived from a high precision/low ADEV TCXO that can be further internally compensated for thermal instability to achieve sub 5ppb thermal frequency stability while the module is in free run and holdover. Due to the ultra low ADEV performance of the module's master clock, the DPLL bandwidth in the BTFC Series is set to <50mHz.

The BTFC Series module auto-detects a valid incoming 3.3V 1PPS reference signal. When a valid 1PPS signal is present, the module has a three stage locking process starting with a frequency locking stage, followed by a fast phase locking stage before achieving full phase locking. The module is allowed to soak in a fast locking stage for a period of time while the TCXO has time to settle. After the frequency locking phase is complete, the 1PPS alignment process moves to within the closest period of the lowest common output frequency. A phase build-out process then adjusts and pulls the remaining phase offset alignment until fully aligned. For phase alignment to take place, the chosen frequencies must be divisible by 8kHz.

The DPLL block implements a digital synthesizer that generates an outgoing 1PPS, a variable frequency synthesized clock made available to the user in Output 3, and a synthesized clock that is sent to the Analog PLL system within the ASIC. Using a low jitter internal VCXO, the module generates multiple clock outputs at frequencies integer related to the VCXO frequency. Output 1 can be provided either as an LVCMOS output signal or a sinewave output signal. Output 2 is a 3.3V CMOS outputs and must be derived by dividing from the VCXO frequency. The output ports each have 20-bit dividers. Output 3 is a 3.3V CMOS output than can be programmed to any 8kHz divisible frequency from 10M to 80MHz and then further divided with an integer post divider with a 16 bit capability.

The BTFC modules incorporate a micro controller that moderate the internal ASIC, set the registers and monitor operations. The module is programmed at the factory but some system commands may be available for changing some registers. The module is intended to be defined and provided to the user as a complete system capable of operating with no user input required.

The BTFC series is RoHS and REACH compliant. It's highly integrated architecture is packaged in a small 21x14mm surface mount footprint allowing for easy integration into host systems.

For more detailed information on the operation of the internal system ASIC NS2D04-1PPS, see the following data sheet.
<http://www.conwin.com/datasheets/tm/tm138.pdf>

2 PHYSICAL CHARACTERISTICS

The BTFC-series is a non-hermetic 21x14mm module with an FR4 substrate and a metal cover.

Figure 2 BTFC Mechanical Drawing

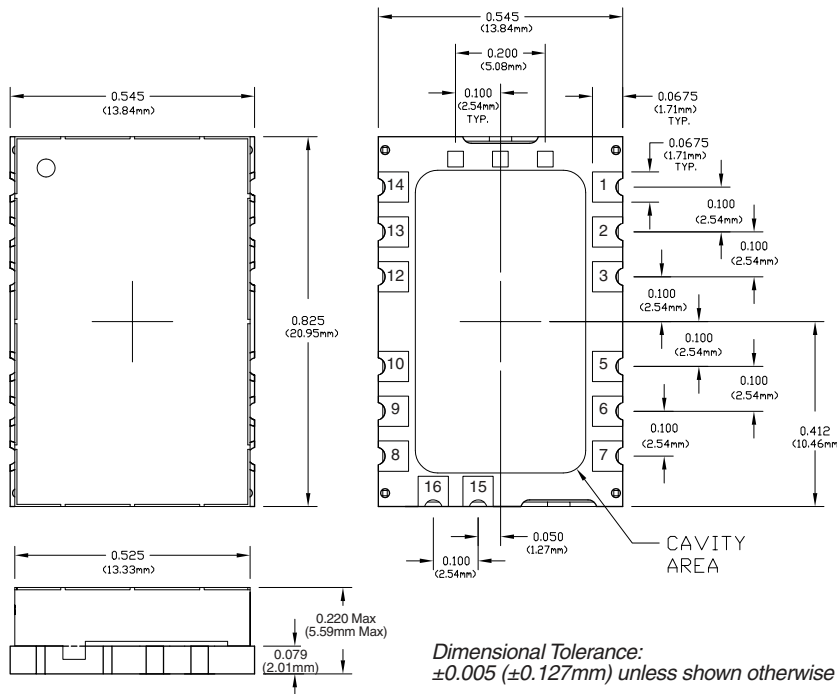

Figure 3: Recommended Pad Layout

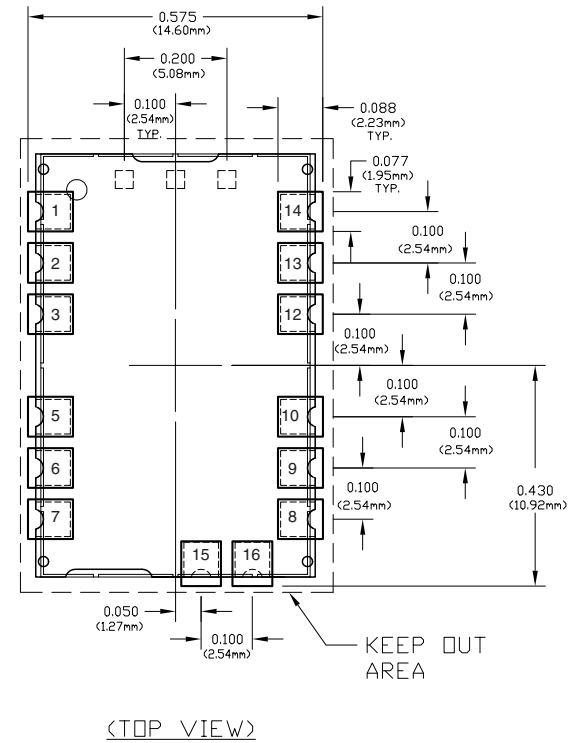

Figure 4 Marking Single Frequency

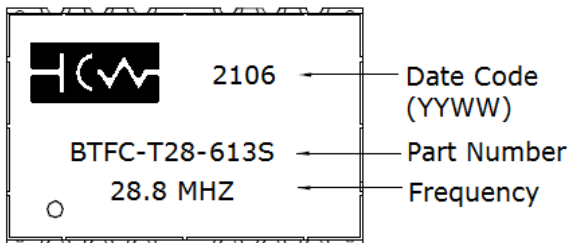
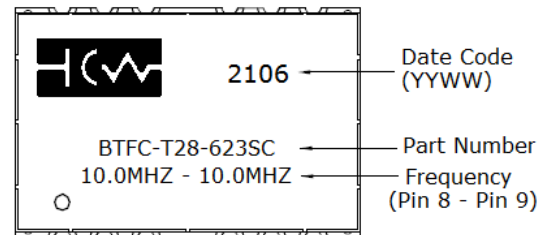

Figure 5: Marking Dual Frequency



2.1 Pin Functions

Pin	Function	Pin	Function	Pin	Function
1	REF_IN 1PPS	7	GND	13	GND Analog
2	N/C	8	FREQ_OUT1 (Sine or LVCMOS)	14	VCC_3V3
3	I2C SCL	9	FREQ_OUT2 or N/C	15	N/C
5	FREQ_OUT3 or N/C	10	HOLD/LOCK STATUS	16	N/C
6	1PPS_OUT	12	I2C SDA		

3 General Description

The BTFC-TCXO series model is a high precision time to frequency converter that accepts a 3.3V LVCMOS 1PPS Reference input and generates a phase and frequency locked 10 MHz 3.3V LVCMOS clock output and a phase locked 1PPS output signal. When the 1PPS Reference is lost, the module immediately enters a holdover mode, maintaining the accuracy of the 10MHz clock to its last locked position with respect to the 1PPS incoming reference. The BTFC module provides a jitter filtered, wander following output signal synchronized to the superior 1PPS input reference signal.

The BTFC Series includes a lock detect alarm output. The module auto-detects a valid 1PPS incoming signal and locks to it. When the 1PPS reference is lost, the module immediately goes into a TCXO supported holdover mode. When the 1PPS signal returns, the module auto detects and regains lock.

Absolute Maximum Ratings

Symbol	Parameter	Minimum	Nominal	Maximum	Units	Notes
V _{CC}	Power Supply Voltage	-0.3	3.3	3.6	Volts	
V _I	Input Voltage	-0.2	-	V _{CC} +0.3V	Volts	
T _x	Storage Temperature	-55	-	125	°C	

Specifications

Symbol	Parameter	Minimum	Nominal	Maximum	Units	Notes
f _{IN}	Input Frequency	-	1	-	PPS	
f _{OUT}	Output Frequencies (LVCMOS)	-	10	160	MHz	
F _{OUT}	Sinewave Output	6	8	10	dBm	
V _{CC}	Supply Voltage	3.13	3.3	3.46	Volts	
I _{CC}	Supply Current	-	225	270	mA	
F _{IN} Input Characteristics						
V _{FIN}	Input Voltage	0.6	3.3	3.6	V _{pp}	
F _{OUT} LVCMOS OUTPUT TYP. 3.3V LVCMOS						
	Frequency Calibration @ 25°C	-1.0	-	1.0	ppm	1
T _{OP}	Operating Temperature	-40	-	85	°C	
	Frequency Stability in Holdover	-0.28	-	0.28	ppm	2
Aging						
	per Day	-40	-	40	ppb	
	First Year	-1.0	-	1.0	ppm	3
	10 Years	-3.0	-	3.0	ppm	
	Freq. shift after reflow soldering	-1.0	-	1.0	ppm	4
SSB Phase Noise 28.8MHz						
	@ 10 Hz offset	-	-76	-	dBc/Hz	
	@ 100 Hz offset	-	-92	-	dBc/Hz	
	@ 1 kHz offset	-	-123	-	dBc/Hz	
	@ 10 kHz offset	-	-137	-	dBc/Hz	
	@ 100 kHz offset	-	-147	-	dBc/Hz	
	@ 1 MHz offset	-	-152	-	dBc/Hz	
	@ 10 MHz offset	-	-153	-	dBc/Hz	
SYM	Output Symmetry	45	-	55	%	
Φ _{DYN}	Dynamic Phase Offset	-	-	1	ns	

Notes:

1. Initial calibration @ 25°C. ±2°C. Specifications at time of shipment after 48 hours of operation.
2. Frequency stability vs. change in temperature. [$\pm(F_{max}-F_{min})/2.F_o$].
3. Two consecutive reflows after 1 hour recovery @ 25°C.
4. Frequency drift over 1 year @ 25°C.

4 SIGNAL DESCRIPTION

4.1 Power Signals

VCC_3V3	Type: Power	Direction: Input	Pin: 14
The Supply Input. This 3.3V ± 5% input supplies power to the module			
GND	Type: Power	Direction: Input/Output	Pin: 7
Input Ground. This is the return path for the vcc_3V3 supply and the ground for the module.			
GND_ANALOG	Type: Power	Direction: Input/Output	Pin: 13
Input Ground_Analog. This is the return path for the vcc_3V3 supply and the analog ground for the module.			

4.2 I/O Signals

TX[0]	Type: I/O	Direction: Output	Pin: 3
I2c SCL PIN			
RX[0]	Type: I/O	Direction: Input	Pin: 12
I2c SDA PIN			
HOLDOVER	Type: I/O	Direction: Output	Pin: 10
Standard software builds use this signal to indicate Holdover status. LOW indicates holdover mode. This signal has a 3.3V CMOS drive.			
LOCKED	Type: I/O	Direction: Output	Pin: 10
Standard software builds use this signal to indicate LOCK status. High indicates locked to 1pps. This signal has a 3.3V CMOS drive.			
FREQ_OUT1	Type: I/O	Direction: Output	Pin: 8
Primary output of the module which is available as either Sinewave or LVCMOS output.			
FREQ_OUT2	Type: I/O	Direction: Output	Pin: 9
Optional Second output from the module that can be provided as 3.3V LVCMOS.			
FREQ_OUT3	Type: I/O	Direction: Output	Pin: 5
Optional Variable Frequency output from the module that can be provided as 3.3V LVCMOS.			
1 PPS_IN	Type: I/O	Direction: Input	Pin: 1
The 1 Pulse-Per-Second Reference Input Signal. This is normally as a 1 pulse aligned with GPS time, generated by an external GPS/GNSS source.			
1 PPS_OUT	Type: I/O	Direction: Output	Pin: 6
The 1 Pulse-Per-Second Reference Signal. This is normally as a 1 pulse aligned with incoming 1PPS_IN signal			

Figure 6:
Typical Phase Noise for 28.8MHz BTFC-series

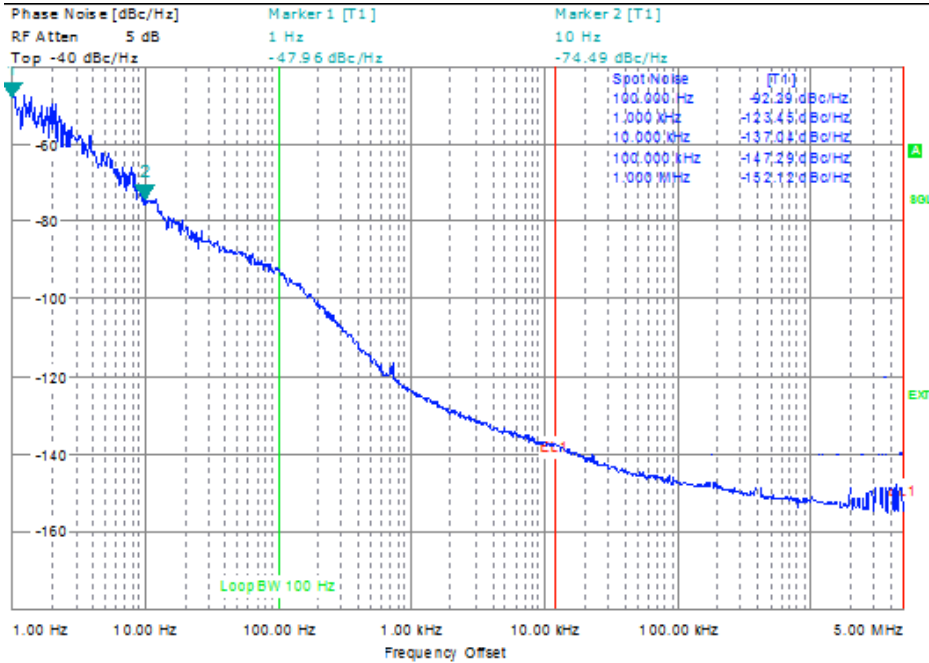

Figure 7:
Solder Profile

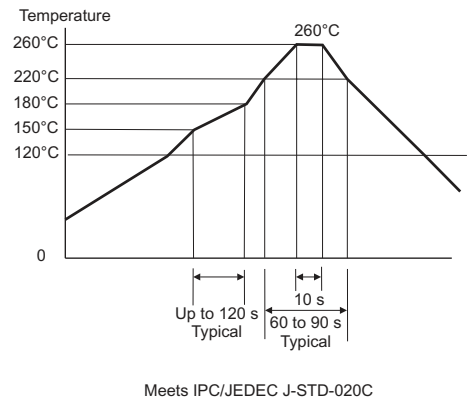

Figure 8: 21 x 14mm Tape and Reel Information

Consult Factory for Tape and Reel Information

Environmental Characteristics

Vibration:	Vibration per Mil Std 883E Method 2007.3 Test Condition A.
Shock:	Mechanical Shock per Mil Std 883E Method 2002.4 Test Condition B.
Soldering Process:	RoHS compliant lead free. See soldering profile above.
Moisture Sensitivity Level:	MSL-3.

Part Number Configuration

Base Model	TCXO Type	Holdover Stability	Temperature Range	# of Outputs	Supply Voltage	Output Logic	Frequency - Frequency
BTFC	T = Std	05: ±5ppb	5: 0 to 70°C	1: 1 Output	3: 3.3Vdc	C: 3.3V CMOS	Pin 8: Freq -
	TCXO	10: ±100ppb	6: -40 to 85°C	2: 2 Outputs	5: 5Vdc	S: Sinewave	
	M=Mems	28: ±280ppb	7: -20 to 75°C			CC: 2x CMOS	Pin 9: Freq
	TCXO					SC: 1 Sine, 1 CMOS	

Example Part Number: BTFC-T28-613S-028.8M (one sinewave output at 28.8MHz)

Example Part Number: BTFC-T28-623SC-010.0M-010.0M (two outputs at 10MHz, Pin 8 sinewave and Pin 9 CMOS)

BTFC-TCXO Series 1PPS Time to Frequency Converter Module



2111 Comprehensive Drive
Aurora, Illinois 60505
Phone: 630-851-4722
Fax: 630-851-5040
www.conwin.com

List of Figures-----	Page
Figure 1 BTFC Block Diagram-----	1
Figure 2 BTFC Mechanical Drawing -----	3
Figure 3 Recommended Pad Layout -----	3
Figure 4 Marking 1 Frequency-----	3
Figure 5 Marking 2 Frequency-----	3
Figure 6 Typical Phase Noise-----	6
Figure 7 Solder Profile -----	6
Figure 8 21 x 14mm Tape and Reel Information -----	6

Revision History

Revision	Date	Note
00	12/09/20	New Release
01	02/16/21	Updated part number table and marking configuration
02	05/18/21	Added pin numbers to mechanical drawing