

**ISO VIEW**  
(FOR DUST CAP OPTION  
REFER TO TABLE)

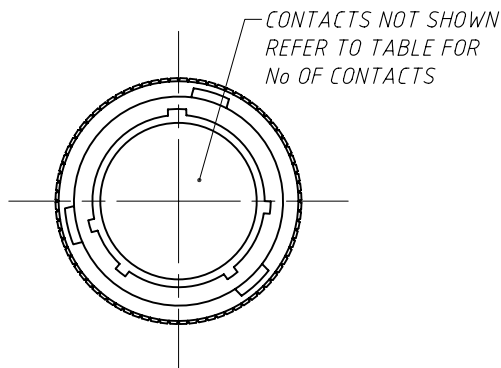

CONTACTS NOT SHOWN  
REFER TO TABLE FOR  
No OF CONTACTS

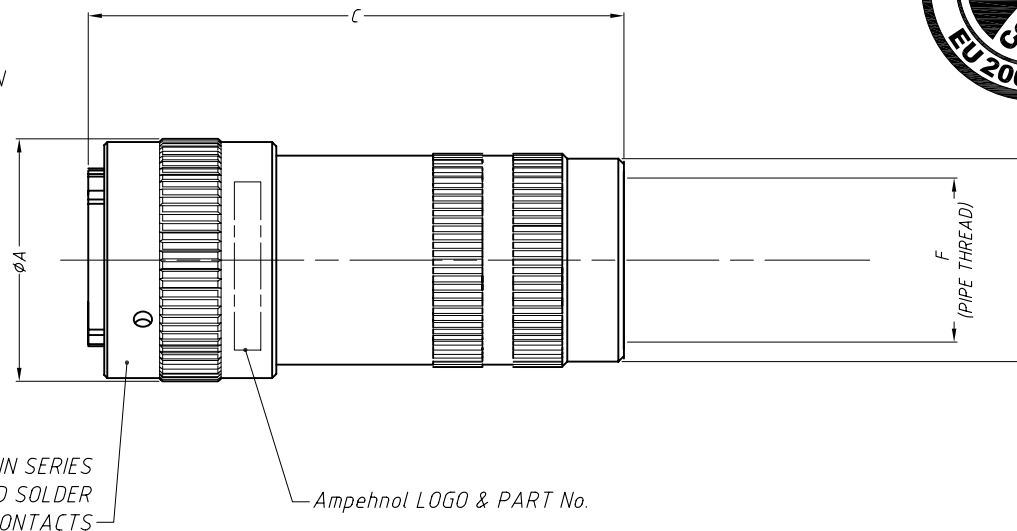

STRAIGHT PLUG 62IN SERIES  
WITH GOLD PLATED SOLDER  
PIN CONTACTS

Amphenol LOGO & PART No.

ITEM	PART No	DUST CAP OPTION	SHELL SIZE	No OF CONTACTS	DIA A	DIA B	C	THREAD F
1	MP-6516-39P	NO	20	39	39.0	34	90	3/4" - 14 NPT
2	MP-6516-39P-C	YES						
3	MP-6516-61P	NO	24	61	45.5	41	100	3/4" - 14 NPT
4	MP-6516-61P-C	YES						

**NOTES:**

- MATERIAL & FINISH: DIE CAST ALUMINUM ALLOY, BLACK FINISH
- ASSEMBLY TO BE SUPPLIED WITH GOLD PLATED PIN CONTACTS

*CUSTOMER DRAWING*

UNLESS OTHERWISE SPECIFIED TOLERANCE TO BE		THIS DOCUMENT IS THE PROPERTY OF AMPHENOL AUSTRALIA PTY. LTD.. NO PART THEREOF MAY BE REPRODUCED AND USED WITHOUT THE PRIOR WRITTEN CONSENT OF THE OWNER			0	FIRST ISSUE	L.V	20-10-05	----
LINEAR	ANGULAR	CAD FILE:	DRN:	DATE:	REV.	CHANGE DETAILS	BY	DATE	CHG/No
X ±	X° ± 1°	55010308000121	L.V	20-10-05					
X.X ±	X°X' ± 30'	BREAK ALL SHARP EDGES AND REMOVE ALL BURRS	MATL:	DATE:					
X.XX ±	X°X'X" ± 15'	DO NOT SCALE	SEE NOTE 1	20/02/06					
DIMENSIONS IN MILLIMETRES		FINISH:	SEE NOTE 2	DATE:					
				20/02/06					
				THIRD ANGLE PROJECTION	SCALE:	NTS	PART No:	SEE TABLE	SIZE: A4
					TITLE: STRAIGHT CABLE PLUG PIN CONTACT		Amphenol		
							Amphenol Australia Pty.Ltd, 2 Fiveways Blvd, Keysborough, Vic.3173		
							DRAWING NO.		SHEET
							55010308-000-2		1 OF 2