

NOTES:

1) MATERIAL:

HOUSING: NYLON(PA), GLASS FILLED, UL94V-0, COLOR: BLACK
 INSULATOR: NYLON(PA), GLASS FILLED, UL94V-0, COLOR: BLACK
 TERMINALS: PHOSPHOR BRONZE, .012/(0.30) THICK
 SHIELD: BRASS, .007/(0.18) THICK

2) FINISH:

TERMINALS:

- A = SELECT GOLD IN CONTACT AREA: 50 MICROINCHES / 1.27 MICROMETERS MIN.,
 *SELECT TIN IN PC TAIL AREA: 100 MICROINCHES / 2.54 MICROMETERS MIN.,
 WITH OVERALL NICKEL UNDERPLATE: 50 MICROINCHES / 1.27 MICROMETERS MIN.
- B = SELECT GOLD IN CONTACT AREA: 30 MICROINCHES / 0.76 MICROMETERS MIN.,
 *SELECT TIN IN PC TAIL AREA: 100 MICROINCHES / 2.54 MICROMETERS MIN.,
 WITH OVERALL NICKEL UNDERPLATE: 50 MICROINCHES / 1.27 MICROMETERS MIN.

SHIELD:

- *100 MICROINCHES / 2.54 MICROMETERS NICKEL OVER 50 MICROINCHES / 1.27 MICROMETERS COPPER UNDERPLATE, PCB GROUND TABS DIPPED IN TIN
- *THE PRIMARY SHIPPING CARTON WILL BE LABELED "COMPLIANT TO RoHS DIRECTIVE 2002/95/EC AND ELV ANNEX II OF DIRECTIVE 2000/53/EC". CARTONS WITHOUT THIS LABEL MAY CONTAIN PRODUCT WITH TIN-LEAD IN THE PC TAILS AND/OR SHIELD.

3) PRODUCT SPECIFICATION AND PROCESSING PARAMETERS: PS-43249.

4) PACKAGING SPECIFICATION:

- UNSHIELDED CONNECTOR ASSEMBLIES PACKAGED IN THERMOFORMED TRAYS PER MOLEX PACKAGING SPECIFICATION PK-43249-004.
- UNSHIELDED CONNECTOR ASSEMBLIES PACKAGED IN TUBES PER MOLEX PACKAGING SPECIFICATION PK-43249-005.
- SHIELDED CONNECTOR ASSEMBLIES PACKAGED IN THERMOFORMED TRAYS PER MOLEX PACKAGING SPECIFICATION PK-44050-004.

5) MATES WITH: MODULAR PLUGS THAT CONFORM TO FCC REGULATION PART 68.5.

6) SEE SHEET 3 FOR SHIELDED JACK ASSEMBLY.

7) SEE SHEETS 5 & 6 FOR P.C. BOARD LAYOUTS.

8) ALL UNTOLERANCED DIMENSIONS ARE SHOWN FOR REFERENCE ONLY.

9) THIS PART CONFORMS TO CLASS B REQUIREMENTS OF COSMETIC SPECIFICATION PS-45499-002.

10) THIS PART CONFORMS TO FCC REGULATION 68.5 AND TIA 1096 FOR MODULAR JACKS.

SIDE/TOP GROUND TAB OPTIONS FOR SHIELDS

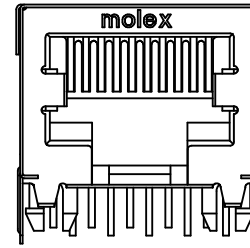

OPTION "A"
NO TOP OR SIDE TABS

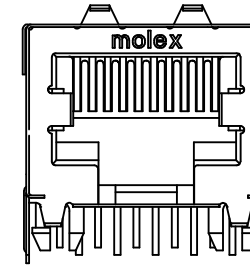

OPTION "B"
TOP TABS

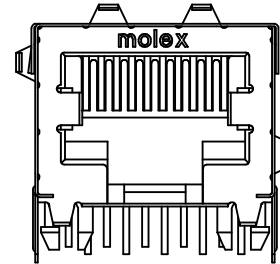

OPTION "C"
TOP AND STAGGERED SIDE TABS

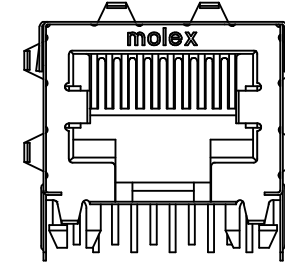

OPTION "D"
TOP AND SIDE TABS

BOTTOM PCB GROUND TAB OPTIONS FOR SHIELDS

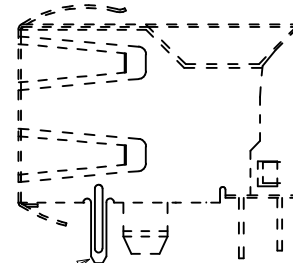

OPTION "E"
OPTIONAL FRONT POSITION

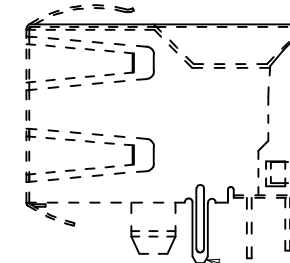

OPTION "F"
OPTIONAL REAR POSITION

NOTE: EITHER PCB GROUND TAB OPTION IS AVAILABLE ON ALL SIDE/TOP TAB CONFIGURATIONS

DRAWING LEGEND

- SHEET 1- NOTES, GROUND TAB OPTIONS
- SHEET 2- UNSHIELDED MODULAR JACK
- SHEET 3- SHIELDED MODULAR JACK WITH OPTIONAL SIDE/TOP GROUND TABS & BOTTOM GROUND TAB WITH OPTIONAL POSITION.
- SHEET 4- PART NUMBER CHARTS
- SHEET 5- FOOTPRINT LAYOUT FOR 8 POSITION HOUSING
- SHEET 6- FOOTPRINT LAYOUT FOR 6 POSITION HOUSING

ADDED NOTE 10 EC NO: UCP2009-0740 DRWN:JKLOSTER/ER 2008/09/29 CHKD:JBELL 2008/10/03 APPR:FSMITH 2008/10/03	QUALITY SYMBOLS	GENERAL TOLERANCES (UNLESS SPECIFIED)	DIMENSION STYLE		SCALE	DESIGN UNITS	THIRD ANGLE PROJECTION													
	▽=0 ▽=0		<table border="1"> <tr> <th></th> <th>mm</th> <th>INCH</th> </tr> <tr> <td>4 PLACES</td> <td>± .---</td> <td>± .---</td> </tr> <tr> <td>3 PLACES</td> <td>± .---</td> <td>± .010</td> </tr> <tr> <td>2 PLACES</td> <td>± 0.25</td> <td>± .---</td> </tr> <tr> <td>1 PLACE</td> <td>± .---</td> <td>± .---</td> </tr> </table>		mm	INCH		4 PLACES	± .---	± .---	3 PLACES	± .---	± .010	2 PLACES	± 0.25	± .---	1 PLACE	± .---	± .---	IN/MM
		mm	INCH																	
	4 PLACES	± .---	± .---																	
3 PLACES	± .---	± .010																		
2 PLACES	± 0.25	± .---																		
1 PLACE	± .---	± .---																		
REV	DESCRIPTION	DRAFT WHERE APPLICABLE MUST REMAIN WITHIN DIMENSIONS	DRAWN BY	DATE	TITLE	MOLEX INCORPORATED														
K1			JTR	1993/06/23	LOW PROFILE RIGHT ANGLE MODULAR JACK ASSEMBLY	SDA-43249														

SEE SHEET 4
 THIS DRAWING CONTAINS INFORMATION THAT IS PROPRIETARY TO MOLEX INCORPORATED AND SHOULD NOT BE USED WITHOUT WRITTEN PERMISSION

UNSHIELDED MODULAR JACK

8 POSITION LOADED 10 SIZE SHOWN

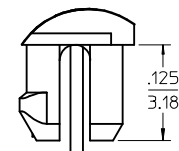
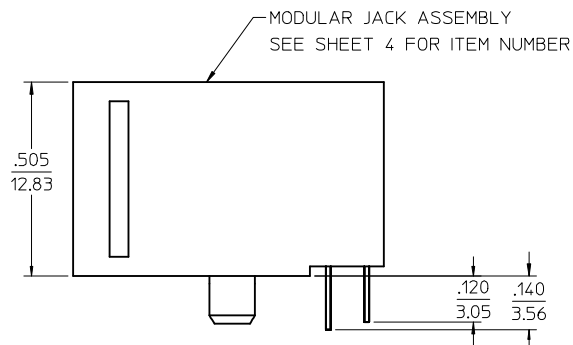
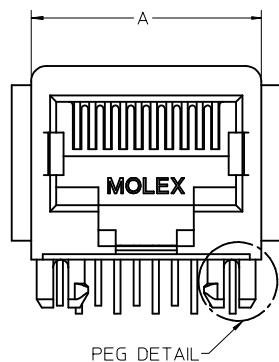

OPTIONAL FLANGE USED FOR FLUSH MODULAR JACK

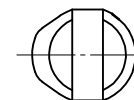
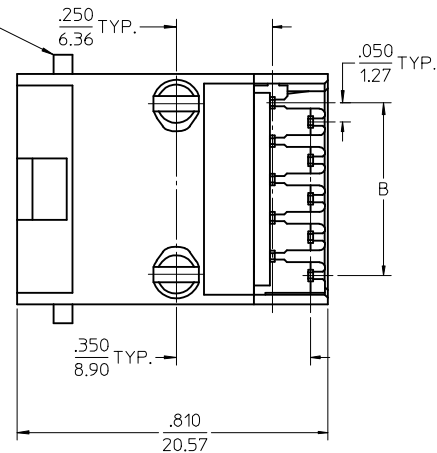

PEG DETAIL SCALE 8:1

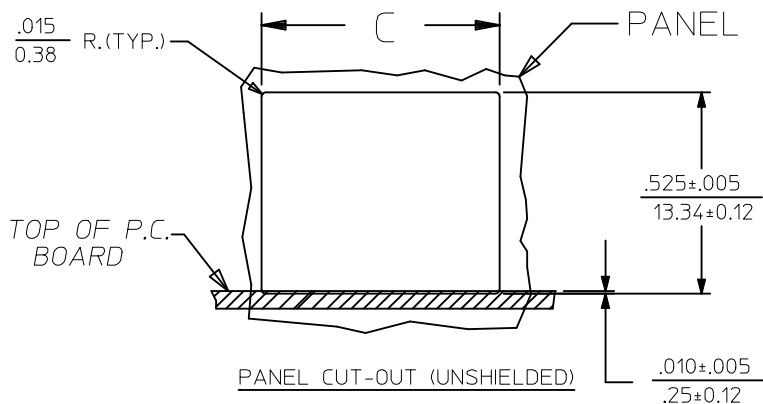

HOUSING SIZE	CIRCUIT SIZE	DIM. A	DIM. B	DIM. C
8	10	.600±.005 (15.24±0.13)	.450±.005 (11.43±0.13)	.620±.005 (15.75±0.13)
8	8	.600±.005 (15.24±0.13)	.350±.005 (8.89±0.13)	.620±.005 (15.75±0.13)
8	4	.600±.005 (15.24±0.13)	.150±.005 (3.81±0.13)	.620±.005 (15.75±0.13)
8	6	.600±.005 (15.24±0.13)	.250±.005 (6.35±0.13)	.620±.005 (15.75±0.13)
6	6	.520±.005 (13.21±0.13)	.250±.005 (6.35±0.13)	.540±.005 (13.72±0.13)
6	4	.520±.005 (13.21±0.13)	.150±.005 (3.81±0.13)	.540±.005 (13.72±0.13)
6	2	.520±.005 (13.21±0.13)	.050±.005 (1.27±0.13)	.540±.005 (13.72±0.13)

SEE SHEET 1 EC NO: UCP2009-0740 DRWN: KLOSTEMEIER 2008/09/29 CHKD: JELL 2008/10/03 APPR: FSMITH 2008/10/03	QUALITY SYMBOLS ▽=0 ▽=0	GENERAL TOLERANCES (UNLESS SPECIFIED)	DIMENSION STYLE IN/MM	SCALE 4:1	DESIGN UNITS INCH	THIRD ANGLE PROJECTION
		4 PLACES ± --- ± --- 3 PLACES ± --- ± .010 2 PLACES ± 0.25 ± --- 1 PLACE ± --- ± --- ANGULAR ± 1/2°	DRAWN BY DATE JTR 1993/06/23 CHECKED BY DATE JTR 1993/06/23 APPROVED BY DATE RAS 1993/06/23	TITLE LOW PROFILE RIGHT ANGLE MODULAR JACK ASSEMBLY	MATERIAL NO. SEE SHEET 4	DOCUMENT NO. SDA-43249
DRAFT WHERE APPLICABLE MUST REMAIN WITHIN DIMENSIONS		THIS DRAWING CONTAINS INFORMATION THAT IS PROPRIETARY TO MOLEX INCORPORATED AND SHOULD NOT BE USED WITHOUT WRITTEN PERMISSION				

MODULAR JACK W/ .007" THICK SHIELD AND OPTIONAL GROUND TABS

8 LOADED 10 VERSION SHOWN WITH GROUND TAB OPTIONS "D" AND "E"

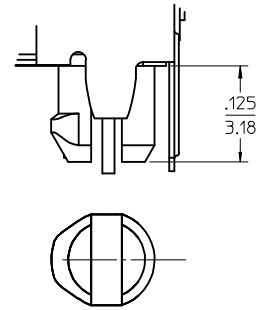
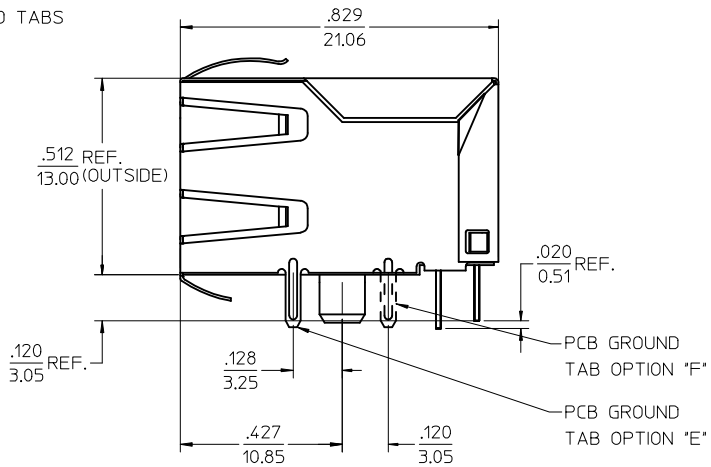
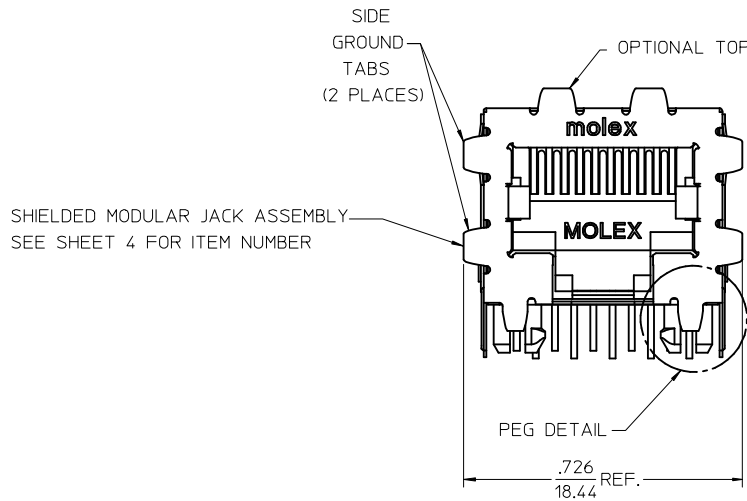

PEG DETAIL
SCALE 8:1

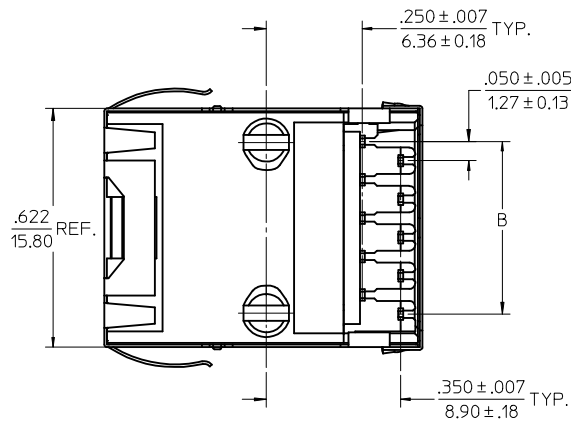
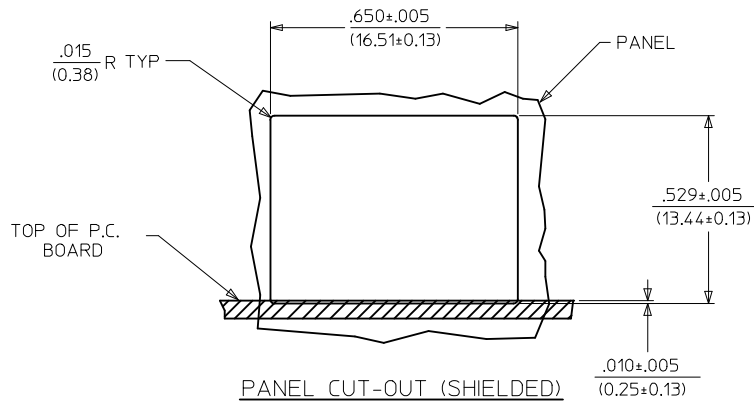

DESCRIPTION OF GROUND TAB OPTIONS:
(SEE SHEET 4 FOR AVAILABLE COMBINATIONS OF OPTIONS)

GROUND TAB OPTION	DESCRIPTION
A	NO GROUND TABS
B	TOP TABS ONLY
C	STAGGERED SIDE TABS
D	TOP AND SIDE TABS
E	PCB GROUND TAB IN FRONT POSITION
F	PCB GROUND TAB IN REAR POSITION

HOUSING SIZE	CIRCUIT SIZE	B
8	10	.450±.005 11.43±0.13
8	8	.350±.005 8.89±0.13

SEE SHEET 1 EC NO: UCP2009-0740 DRWN: KLOSTNER/ER 2008/09/29 CHKD: BELL 2008/10/03 APPR: FSMITH 2008/10/03	QUALITY SYMBOLS ▽=0 ▽=0	GENERAL TOLERANCES (UNLESS SPECIFIED) <table border="1"> <thead> <tr> <th></th> <th>mm</th> <th>INCH</th> </tr> </thead> <tbody> <tr> <td>4 PLACES ±</td> <td>---</td> <td>---</td> </tr> <tr> <td>3 PLACES ±</td> <td>---</td> <td>±.010</td> </tr> <tr> <td>2 PLACES ±</td> <td>0.25</td> <td>---</td> </tr> <tr> <td>1 PLACE ±</td> <td>---</td> <td>---</td> </tr> </tbody> </table> ANGULAR ±1/2°		mm	INCH	4 PLACES ±	---	---	3 PLACES ±	---	±.010	2 PLACES ±	0.25	---	1 PLACE ±	---	---	DIMENSION STYLE IN/MM	SCALE 4:1	DESIGN UNITS INCH	THIRD ANGLE PROJECTION
		mm	INCH																		
	4 PLACES ±	---	---																		
	3 PLACES ±	---	±.010																		
2 PLACES ±	0.25	---																			
1 PLACE ±	---	---																			
DRAWN BY JTR	DATE 1993/06/23	TITLE LOW PROFILE RIGHT ANGLE MODULAR JACK ASSEMBLY																			
CHECKED BY JTR	DATE 1993/06/23	APPROVED BY RAS																			
DATE 1993/06/23	MATERIAL NO. SEE SHEET 4	DOCUMENT NO. SDA-43249	SHEET NO. 3 OF 6	THIS DRAWING CONTAINS INFORMATION THAT IS PROPRIETARY TO MOLEX INCORPORATED AND SHOULD NOT BE USED WITHOUT WRITTEN PERMISSION																	

FLUSH MOUNT (UNSHIELDED)

ASSEMBLY ITEM NUMBER	CONNECTOR SIZE	NUMBER OF CIRCUITS	TERMINAL PLATING OPTION
43249-8001	8	10	A
43249-8004	8	8	A
43249-8010	8	6	A
43249-6001	6	6	A
43249-6004	6	4	A
43249-6007	6	2	A

SHIELDED, .007" THICK

ASSEMBLY ITEM NUMBER	CONN. SIZE	NUMBER OF CIRCUITS	TERMINAL PLATING OPTION	SIDE/TOP PANEL GROUND TAB OPTION	PCB GROUND TAB OPTION	PACKAGING OPTION
43249-8900	8	10	A	A	E	TRAY
43249-8901	8	10	A	B	E	TRAY
43249-8902	8	10	A	C	E	TRAY
43249-8903	8	10	A	D	E	TRAY
43249-8908	8	10	A	A	F	TRAY
43249-8909	8	10	A	B	F	TRAY
43249-8910	8	10	A	C	F	TRAY
43249-8911	8	10	A	D	F	TRAY
43249-8916	8	8	A	A	E	TRAY
43249-8917	8	8	A	B	E	TRAY
43249-8918	8	8	A	C	E	TRAY
43249-8919	8	8	A	D	E	TRAY
43249-8920	8	8	B	A	E	TRAY
43249-8924	8	8	A	A	F	TRAY
43249-8925	8	8	A	B	F	TRAY
43249-8926	8	8	A	C	F	TRAY
43249-8927	8	8	A	D	F	TRAY

FLANGELESS (UNSHIELDED)

ASSEMBLY ITEM NUMBER	CONNECTOR SIZE	NUMBER OF CIRCUITS	TERMINAL PLATING OPTION
43249-8101	8	10	A
43249-8102	8	10	B
43249-8104	8	8	A
43249-8105	8	8	B
43249-8116	8	6	A
43249-8119	8	4	A
43249-6101	6	6	A
43249-6104	6	4	A
43249-6107	6	2	A

FLANGELESS (UNSHIELDED)

(SHIPPED IN TUBES)

43249-6501	6	6	A
43249-6504	6	4	A

SEE SHEET 1 EC NO: UCP2009-0740 DRWN: KLOSTEMEIER 2008/09/29 CHKD: BELLS 2008/10/03 APPR: FSMITH 2008/10/03	QUALITY SYMBOLS	GENERAL TOLERANCES (UNLESS SPECIFIED) <table border="1"> <thead> <tr> <th></th> <th>mm</th> <th>INCH</th> </tr> </thead> <tbody> <tr><td>4 PLACES</td><td>± .005</td><td>± .0005</td></tr> <tr><td>3 PLACES</td><td>± .005</td><td>± .010</td></tr> <tr><td>2 PLACES</td><td>± 0.25</td><td>± .005</td></tr> <tr><td>1 PLACE</td><td>± .005</td><td>± .005</td></tr> </tbody> </table> ANGULAR ±1/2°		mm	INCH	4 PLACES	± .005	± .0005	3 PLACES	± .005	± .010	2 PLACES	± 0.25	± .005	1 PLACE	± .005	± .005	DIMENSION STYLE	SCALE	DESIGN UNITS	THIRD ANGLE PROJECTION
			mm	INCH																	
	4 PLACES		± .005	± .0005																	
	3 PLACES		± .005	± .010																	
2 PLACES	± 0.25	± .005																			
1 PLACE	± .005	± .005																			
		IN/MM	4:1	INCH																	
			DRAWN BY	DATE	TITLE LOW PROFILE RIGHT ANGLE MODULAR JACK ASSEMBLY																
			JTR	1993/06/23																	
			CHECKED BY	DATE	MOLEX INCORPORATED SDA-43249																
			JTR	1993/06/23																	
			APPROVED BY	DATE	DOCUMENT NO. SDA-43249																
			RAS	1993/06/23																	
			MATERIAL NO.	SIZE	SHEET NO. 4 OF 6																
				C	THIS DRAWING CONTAINS INFORMATION THAT IS PROPRIETARY TO MOLEX INCORPORATED AND SHOULD NOT BE USED WITHOUT WRITTEN PERMISSION																

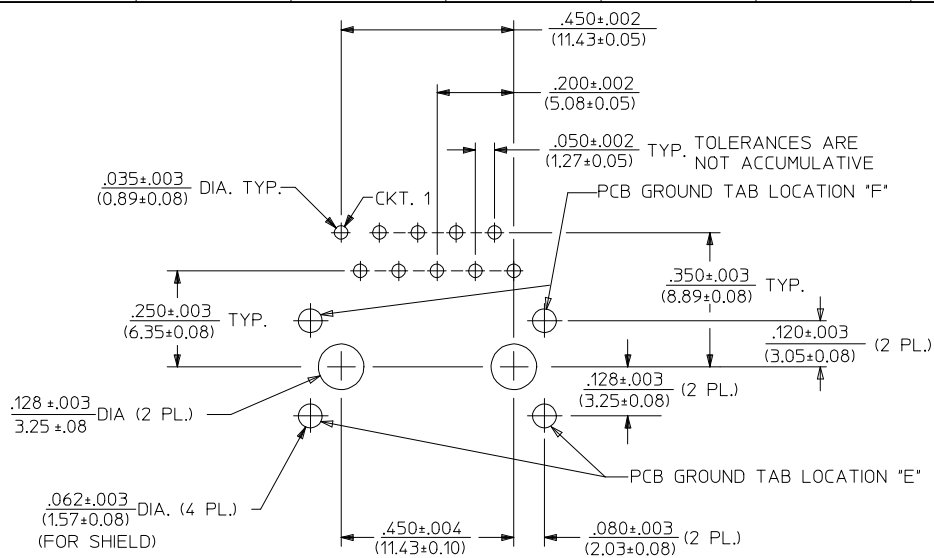

PC BOARD LAYOUT FOR SIZE 8, 10 CIRCUIT
(COMPONENT SIDE OF BOARD)

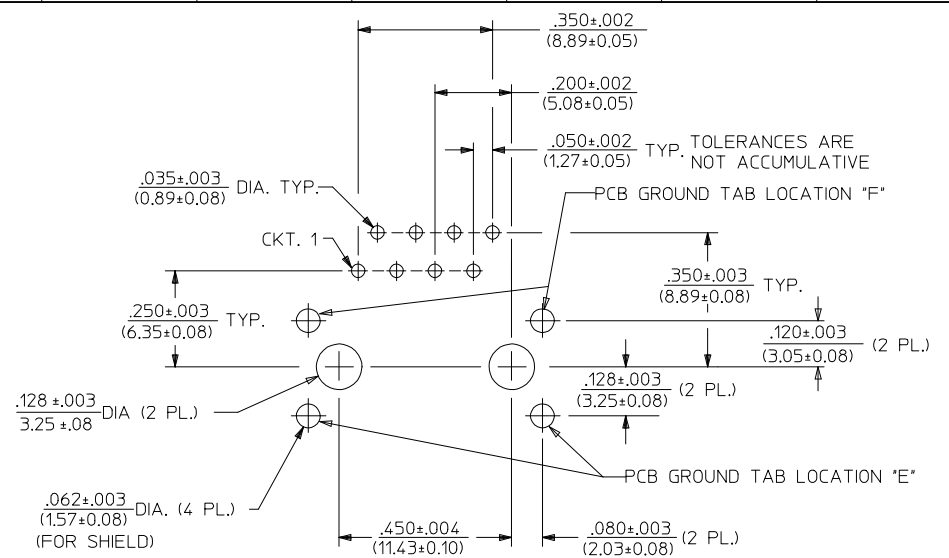

PC BOARD LAYOUT FOR SIZE 8, 8 CIRCUIT
(COMPONENT SIDE OF BOARD)

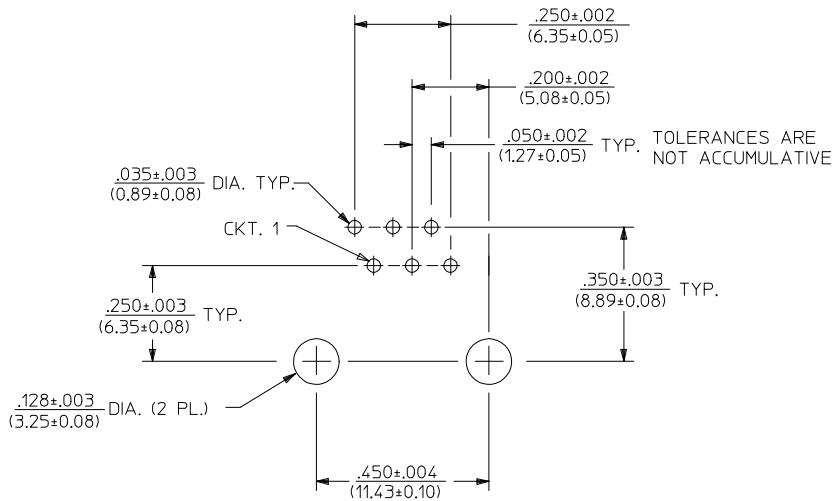

PC BOARD LAYOUT FOR SIZE 8, 6 CIRCUIT
(COMPONENT SIDE OF BOARD)

NOTES:
1. RECOMMENDED PCB THICKNESS: .062 ± .005 (1.57 ± 0.13)

SEE SHEET 1 EC NO: UCP2009-0740 DRAWN: KLOSTEMEIER 2008/09/29 CHKD: J.BELL 2008/10/03 APPR: F.SMITH 2008/10/03	QUALITY SYMBOLS ▽=0 ▽=0	GENERAL TOLERANCES (UNLESS SPECIFIED)	DIMENSION STYLE IN/MM	SCALE 4:1	DESIGN UNITS INCH	THIRD ANGLE PROJECTION
		4 PLACES ± --- ± --- 3 PLACES ± --- ± .010 2 PLACES ± 0.25 ± --- 1 PLACE ± --- ± --- ANGULAR ± 1/2°	mm INCH DRAWN BY DATE JTR 1993/06/23 CHECKED BY DATE JTR 1993/06/23 APPROVED BY DATE RAS 1993/06/23	TITLE LOW PROFILE RIGHT ANGLE MODULAR JACK ASSEMBLY	MATERIAL NO. SEE SHEET 4	DOCUMENT NO. SDA-43249
DRAFT WHERE APPLICABLE MUST REMAIN WITHIN DIMENSIONS		THIS DRAWING CONTAINS INFORMATION THAT IS PROPRIETARY TO MOLEX INCORPORATED AND SHOULD NOT BE USED WITHOUT WRITTEN PERMISSION				

13 12 11 10 9 8 7 6 5 4 3 2 1

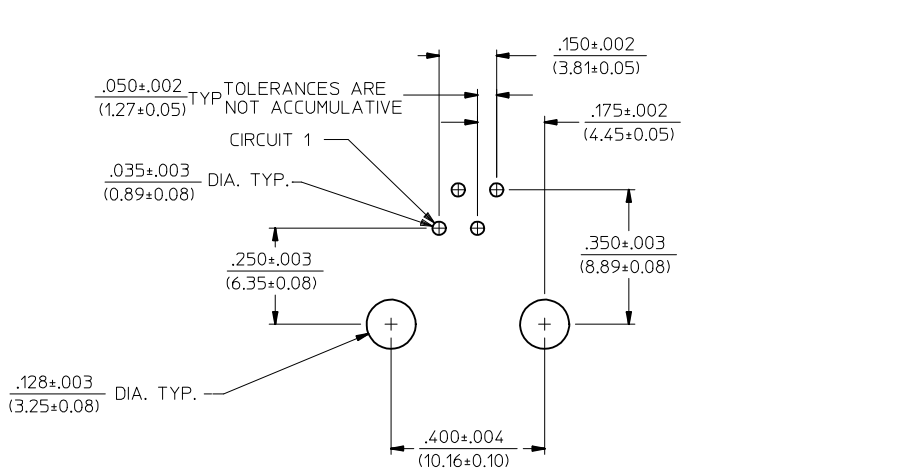
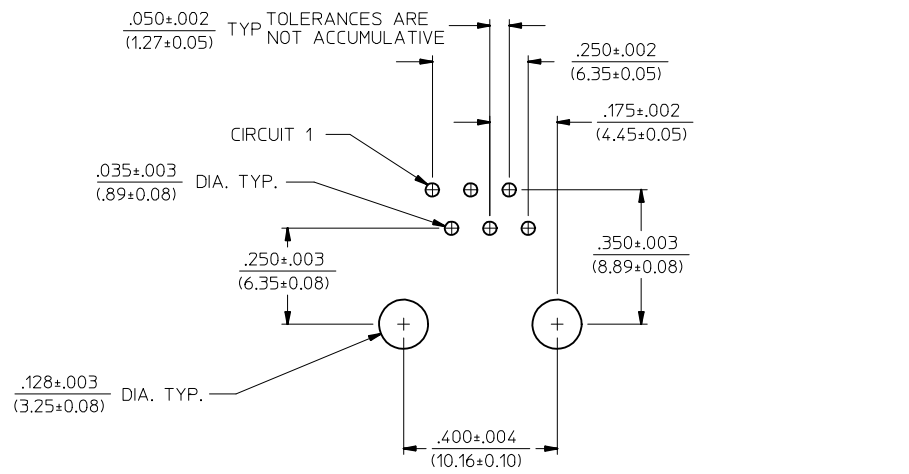

PC BOARD LAYOUT FOR SIZE 6, 6 CIRCUIT
(COMPONENT SIDE OF BOARD)

PC BOARD LAYOUT FOR SIZE 6, 4 CIRCUIT
(COMPONENT SIDE OF BOARD)

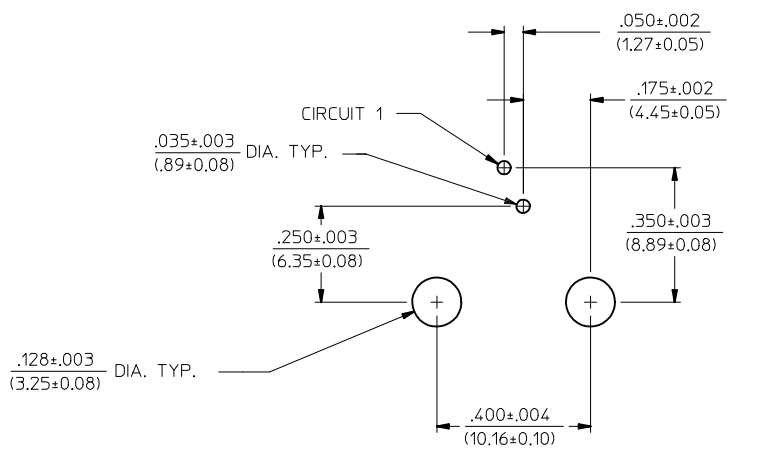

PC BOARD LAYOUT FOR SIZE 6, 2 CIRCUIT
(COMPONENT SIDE OF BOARD)

NOTES:
1. RECOMMENDED PCB THICKNESS: .062±.005/(1.57±0.13)

SEE SHEET 1 IEC NO: UCP2009-0740 DRWN: KLOSTEMEIER 2008/09/29 CHKD: JELL 2008/10/03 APPR: FSMITH 2008/10/03	DESCRIPTION K1	QUALITY SYMBOLS	GENERAL TOLERANCES (UNLESS SPECIFIED) <table border="1"> <tr> <th></th> <th>mm</th> <th>INCH</th> </tr> <tr> <td>4 PLACES</td> <td>± .---</td> <td>± .---</td> </tr> <tr> <td>3 PLACES</td> <td>± .---</td> <td>± .010</td> </tr> <tr> <td>2 PLACES</td> <td>± 0.25</td> <td>± .---</td> </tr> <tr> <td>1 PLACE</td> <td>± .---</td> <td>± .---</td> </tr> </table> ANGULAR ±1/2°		mm	INCH	4 PLACES	± .---	± .---	3 PLACES	± .---	± .010	2 PLACES	± 0.25	± .---	1 PLACE	± .---	± .---	DIMENSION STYLE IN/MM DRAWN BY DATE JTR 1993/06/23	SCALE 4:1 DESIGN UNITS INCH	THIRD ANGLE PROJECTION LOW PROFILE RIGHT ANGLE MODULAR JACK ASSEMBLY MOLEX INCORPORATED SDA-43249 SHEET NO. 6 OF 6
				mm	INCH																
		4 PLACES		± .---	± .---																
		3 PLACES		± .---	± .010																
2 PLACES	± 0.25	± .---																			
1 PLACE	± .---	± .---																			
DRAFT WHERE APPLICABLE MUST REMAIN WITHIN DIMENSIONS	APPROVED BY DATE RAS 1993/06/23	MATERIAL NO. SEE SHEET 4	DOCUMENT NO.																		
SIZE C	THIS DRAWING CONTAINS INFORMATION THAT IS PROPRIETARY TO MOLEX INCORPORATED AND SHOULD NOT BE USED WITHOUT WRITTEN PERMISSION		MOLEX																		