

NO. OF CIRCUITS	DIMENSION "A"		DIMENSION "B"		MATERIAL NO. -C OPTION	MATERIAL NO. -50 OPTION
02	20.9	[0.82]	9.53	[.375]	387506302	387507502
03	30.4	[1.20]	19.05	[.750]	387506303	387507503
04	39.9	[1.57]	28.58	[1.125]	387506304	387507504
05	49.5	[1.95]	38.10	[1.500]	387506305	387507505
06	59.0	[2.32]	47.63	[1.875]	387506306	387507506
07	68.5	[2.70]	57.15	[2.250]	387506307	387507507
08	78.0	[3.07]	66.68	[2.625]	387506308	387507508
09	87.6	[3.45]	76.20	[3.000]	387506309	387507509
10	97.1	[3.82]	85.73	[3.375]	387506310	387507510
11	106.6	[4.20]	95.25	[3.750]	387506311	387507511
12	116.1	[4.57]	104.78	[4.125]	387506312	387507512
13	125.7	[4.95]	114.30	[4.500]	387506313	387507513
14	135.2	[5.32]	123.83	[4.875]	387506314	387507514
15	144.7	[5.70]	133.35	[5.250]	387506315	387507515
16	154.2	[6.07]	142.88	[5.625]	387506316	387507516
17	163.8	[6.45]	152.40	[6.000]	387506317	387507517
18	173.3	[6.82]	161.93	[6.375]	387506318	387507518
19	182.8	[7.20]	171.45	[6.750]	387506319	387507519
20	192.3	[7.57]	180.98	[7.125]	387506320	387507520
21	201.9	[7.95]	190.50	[7.500]	387506321	387507521
22	211.4	[8.32]	200.03	[7.875]	387506322	387507522
23	220.9	[8.70]	209.55	[8.250]	387506323	387507523
24	230.4	[9.07]	219.08	[8.625]	387506324	387507524
25	240.0	[9.45]	228.60	[9.000]	387506325	387507525
26	249.5	[9.82]	238.13	[9.375]	387506326	387507526

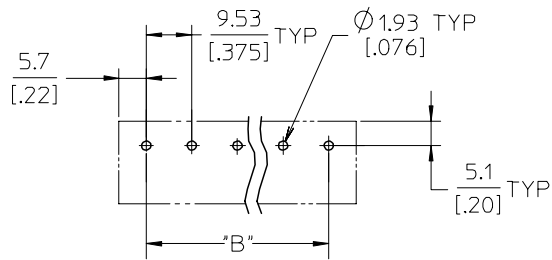
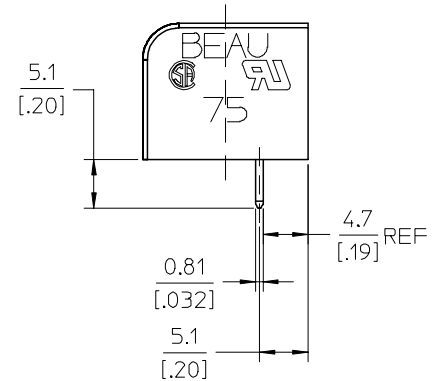
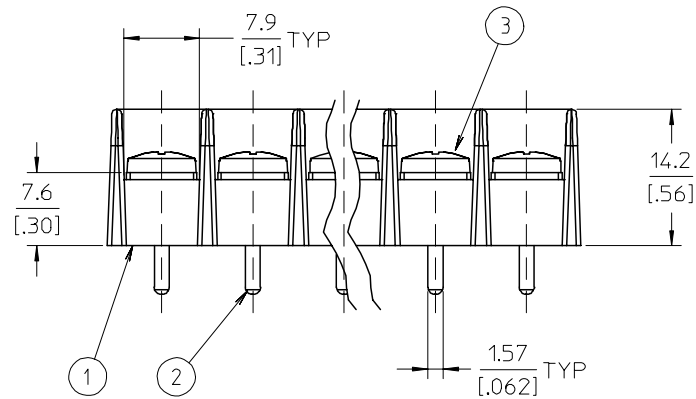
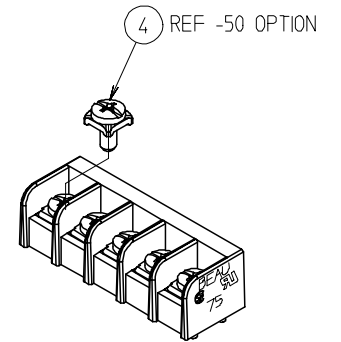
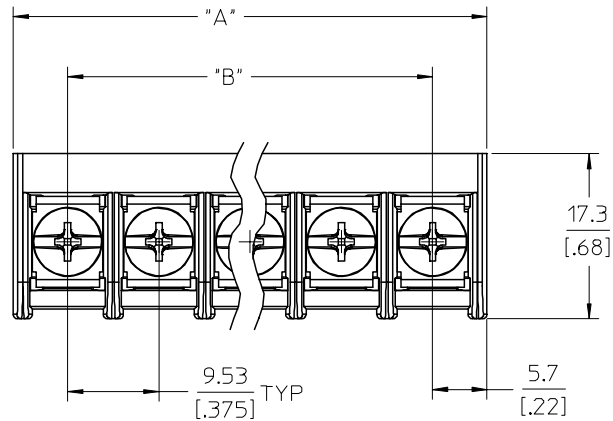

NOTES:

1. MATERIAL: SEE TABLE
2. FINISHES: SEE TABLE
3. PRODUCT SPECIFICATION: NOT REQUIRED
4. INCH DIMENSIONS ARE SHOWN IN BRACKETS [XXX].
5. "XX" REFERS TO QUANTITY OF CIRCUITS.
6. PACKAGING: NOT REQUIRED
7. MATES WITH: NOT APPLICABLE

ITEM	QTY	DESCRIPTION	MATERIAL	FINISH
4	XX	SCREW W/SO WASHER, #6-32X.250, PHIL-SLOT, -50	STEEL	ZINC CHROMATE
3	XX	SCREW, #6-32X.250, BHD, PHIL-SLOT, STD	STEEL	ZINC CHROMATE
2	XX	TERMINAL, PC	BRASS	TIN PLATE
1	1	INSULATOR	THERMOPLASTIC	BLACK

INITIAL RELEASE  
EC NO: ETC2006-0227  
DRW:HEHLE 2006/02/06  
CHKD:RDEROSS 2006/02/07  
APPR:RDEROSS 2006/02/09

QUALITY SYMBOLS

GENERAL TOLERANCES (UNLESS SPECIFIED)

	mm	INCH
4 PLACES	± ---	±.0015
3 PLACES	± 0.038	±.005
2 PLACES	± 0.13	±.01
1 PLACE	± 0.3	± ---

ANGULAR ± 2 °

DRAFT WHERE APPLICABLE  
MUST REMAIN WITHIN DIMENSIONS

DIMENSION STYLE  
MM/IN

DRAWN BY: EHILE DATE: 2006/02/06  
CHECKED BY: RDEROSS DATE: 2006/02/06  
APPROVED BY: RDEROSS DATE: 2006/02/06

MATERIAL NO. SEE CHART

SCALE 2:1  
DESIGN UNITS INCH  
THIRD ANGLE PROJECTION

TITLE 9.53MM [.375] SR BTS, PC, CS ASSY, -C, -50

MATERIAL NO. MOLEX INCORPORATED  
DOCUMENT NO. SD-38750-003

SHEET NO. 1 OF 1

THIS DRAWING CONTAINS INFORMATION THAT IS PROPRIETARY TO MOLEX INCORPORATED AND SHOULD NOT BE USED WITHOUT WRITTEN PERMISSION