

Resin Dipped Type

Series: EF Type : F

■ Features Lead wire terminal (Standard)

Japan



■ Specifications

Category temp. range	-55 to + 85°C (W.V. ≥ 10V.DC : -55 to 105°C)	
Rated W.V. Range	4 to 50 V .DC	
Nominal Cap. Range	0.1 to 220 μ F	
Capacitance Tolerance	±20 % or ±10% (120Hz/+20°C)	
DC Leakage Current	I ≤ 0.008 CV or 0.05 (μA) after 2 minutes application of rated working voltage at +20 °C. (whichever is the greater)	
tan δ	Please see the attached standard products list	
Moisture Resistance	After 500 hours exposure at +40 °C and 90 to 95 % R.H. without load, the capacitor shall meet the following limits.	
	Capacitance change	± 10 % of initial measured value
	tan δ	≤ 150 % of initial specified value
	DC leakage current	0.012 CV or 0.75 (μA) max. whichever is the greater.
Endurance	After 2000 hours application of rated DC working voltage at +85°C or 1000 hours at +105°C with derated voltage for 10 to 50 W.V., the capacitor shall meet the following limits.	
	Capacitance change	±10% of initial measured value
	tan δ	≤ initial specified value
	DC leakage current	0.01 CV or 0.625 (μA) max. whichever is the greater

■ Marking

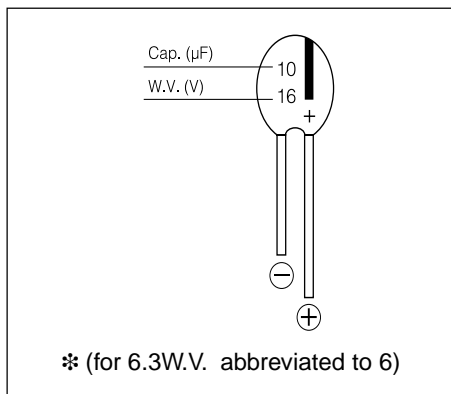

■ Dimensions in mm (not to scale)

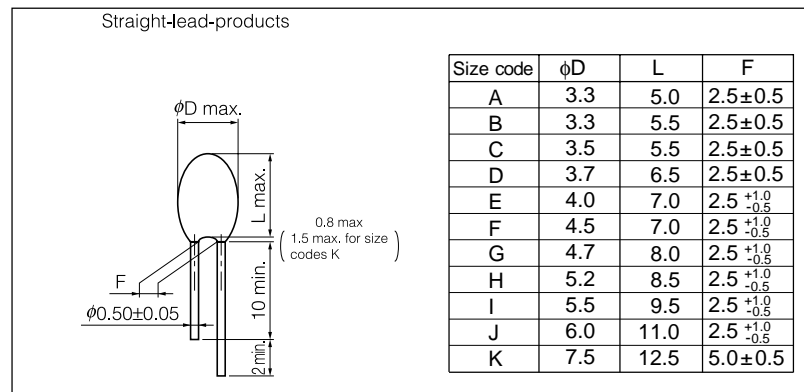

■ Case size

Cap.(μF)	W.V.(V.DC)	4(OG)	6.3(OJ)	10(1A)	16(1C)	25(1E)	35(1V)	50(1H)
0.10 (104)							A	A
0.15 (154)							A	A
0.22 (224)							A	B
0.33 (334)							A	C
0.47 (474)							B	D
0.68 (684)							B	D
1.0 (105)					A	B	C	E
1.5 (155)					B	C	C	F
2.2 (225)				B	C	C	D	G
3.3 (335)				C	C	D	E	H
4.7 (475)			C	C	D	E	F	I
6.8 (685)	C	C	D	D	E	F	H	
10 (106)	C	D	E	F	F	H	I	
15 (156)	D	E	F	G	I	J	J	
22 (226)	E	F	G	H	J	K	K	
33 (336)	F	G	H	I	I			
47 (476)	G	H	I	J	J			
68 (686)	H	I	J	K	K			
100 (107)	I	J	K					
150 (157)	J	K						
220 (227)	K							

Note: 1. () shows W.V. and capacitance code.
2. Products designated by (●) have the voltage code on the body.

Rev.02/04

■ Standard Products

W.V. (V)	Cap. (120Hz) (+20°C) (μF)	Body Size			Specification		Lead Space			Part No.	Min. Packaging Qty	
		Dia. (mm)	Length (mm)	Size Code	tanδ (120Hz) (+20°C)	L.C (μA)	Straight (mm)	Taping B1 (mm)	Taping BB (mm)		Straight Leads (pcs)	Taping (pcs)
4	6.8	3.5 [4.5]	5.5 [9]	C	0.1	0.3	2.5	2.5	5.0	ECSF0GE685()	200	2000
	10	3.5 [4.5]	5.5 [9]	C	0.1	0.4	2.5	2.5	5.0	ECSF0GE106()	200	2000
	15	3.7 [5]	6.5 [9]	D	0.1	0.5	2.5	2.5	5.0	ECSF0GE156()	200	2000
	22	4 [5.5]	7 [9]	E	0.1	0.8	2.5	2.5	5.0	ECSF0GE226()	200	2000
	33	4.5 [5.5]	7 [10]	F	0.1	1.1	2.5	2.5	5.0	ECSF0GE336()	200	2000
	47	4.7 [6]	8 [11]	G	0.1	1.6	2.5	2.5	5.0	ECSF0GE476()	200	2000
	68	5.2 [6]	8.5[11.5]	H	0.1	2.2	2.5	2.5	5.0	ECSF0GE686()	200	2000
	100	5.5 [6.5]	9.5[12.5]	I	0.1	3.2	2.5	2.5	5.0	ECSF0GE107()	200	2000
	150	6	11	J	0.1	4.8	2.5			ECSF0GE157()	200	
	220	7.5	12.5	K	0.1	7.1	5.0			ECSF0GE227()	100	
6.3	4.7	3.5 [4.5]	5.5 [9]	C	0.06	0.3	2.5	2.5	5.0	ECSF0JE475()	200	2000
	6.8	3.5 [4.5]	5.5 [9]	C	0.06	0.4	2.5	2.5	5.0	ECSF0JE685()	200	2000
	10	3.7 [5]	6.5 [9]	D	0.06	0.6	2.5	2.5	5.0	ECSF0JE106()	200	2000
	15	4 [5.5]	7 [9]	E	0.06	0.8	2.5	2.5	5.0	ECSF0JE156()	200	2000
	22	4.5 [5.5]	7 [10]	F	0.06	1.2	2.5	2.5	5.0	ECSF0JE226()	200	2000
	33	4.7 [6]	8 [11]	G	0.06	1.7	2.5	2.5	5.0	ECSF0JE336()	200	2000
	47	5.2 [6]	8.5[11.5]	H	0.06	2.4	2.5	2.5	5.0	ECSF0JE476()	200	2000
	68	5.5 [6.5]	9.5[12.5]	I	0.06	3.5	2.5	2.5	5.0	ECSF0JE686()	200	2000
	100	6	11	J	0.08	5.1	2.5			ECSF0JE107()	200	
	150	7.5	12.5	K	0.08	7.6	5.0			ECSF0JE157()	100	
10	2.2	3.3 [4.5]	5.5 [9]	B	0.06	0.2	2.5	2.5	5.0	ECSF1AE225()	200	2000
	3.3	3.5 [4.5]	5.5 [9]	C	0.06	0.3	2.5	2.5	5.0	ECSF1AE335()	200	2000
	4.7	3.5 [4.5]	5.5 [9]	C	0.06	0.4	2.5	2.5	5.0	ECSF1AE475()	200	2000
	6.8	3.7 [5]	6.5 [9]	D	0.06	0.6	2.5	2.5	5.0	ECSF1AE685()	200	2000
	10	4 [5.5]	7 [9]	E	0.06	0.8	2.5	2.5	5.0	ECSF1AE106()	200	2000
	15	4.5 [5.5]	7 [10]	F	0.06	1.2	2.5	2.5	5.0	ECSF1AE156()	200	2000
	22	4.7 [6]	8 [11]	G	0.06	1.8	2.5	2.5	5.0	ECSF1AE226()	200	2000
	33	5.2 [6]	8.5[11.5]	H	0.06	2.7	2.5	2.5	5.0	ECSF1AE336()	200	2000
	47	5.5 [6.5]	9.5[12.5]	I	0.06	3.8	2.5	2.5	5.0	ECSF1AE476()	200	2000
	68	6	11	J	0.06	5.5	2.5			ECSF1AE686()	200	
100	7.5	12.5	K	0.08	8.0	5.0			ECSF1AE107()	100		
16	1	3.3 [4.5]	5 [9]	A	0.04	0.2	2.5	2.5	5.0	ECSF1CE105()	200	2000
	1.5	3.3 [4.5]	5.5 [9]	B	0.06	0.2	2.5	2.5	5.0	ECSF1CE155()	200	2000
	2.2	3.5 [4.5]	5.5 [9]	C	0.06	0.3	2.5	2.5	5.0	ECSF1CE225()	200	2000
	3.3	3.5 [4.5]	5.5 [9]	C	0.06	0.5	2.5	2.5	5.0	ECSF1CE335()	200	2000
	4.7	3.7 [5]	6.5 [9]	D	0.06	0.7	2.5	2.5	5.0	ECSF1CE475()	200	2000
	6.8	4 [5.5]	7 [9]	E	0.06	0.9	2.5	2.5	5.0	ECSF1CE685()	200	2000
	10	4.5 [5.5]	7 [10]	F	0.06	1.3	2.5	2.5	5.0	ECSF1CE106()	200	2000
	15	4.7 [6]	8 [11]	G	0.06	2.0	2.5	2.5	5.0	ECSF1CE156()	200	2000
	22	5.2 [6]	8.5[11.5]	H	0.06	2.9	2.5	2.5	5.0	ECSF1CE226()	200	2000
	33	5.5 [6.5]	9.5[12.5]	I	0.06	4.3	2.5	2.5	5.0	ECSF1CE336()	200	2000
	47	6	11	J	0.06	6.1	2.5			ECSF1CE476()	200	
	68	7.5	12.5	K	0.06	8.8	5.0			ECSF1CE686()	100	

Diameter, length in brackets [] represent the formed lead type such as H,KH,BB,2B

When requesting taped product, please put the letter "B1" or "BB" between the "()".

Design, Specifications are subject to change without notice. Ask factory for technical specifications before purchase and/or use. Whenever a doubt about safety arises from this product, please inform us immediately for technical consultation without fail.

Standard Products

W.V. (V)	Cap. (120Hz) (+20°C) (μF)	Body Size			Specification		Lead Space			Part No.	Min. Packaging Q'ty	
		Dia. (mm)	Length (mm)	Size Code	tanδ (120Hz) (+20°C)	L.C (μA)	Straight (mm)	Taping B1 (mm)	Taping BB (mm)		Straight Leads (pcs)	Taping (pcs)
25	1	3.3 [4.5]	5.5 [9]	B	0.04	0.2	2.5	2.5	5.0	ECSF1EE105()	200	2000
	1.5	3.5 [4.5]	5.5 [9]	C	0.06	0.3	2.5	2.5	5.0	ECSF1EE155()	200	2000
	2.2	3.5 [4.5]	5.5 [9]	C	0.06	0.5	2.5	2.5	5.0	ECSF1EE225()	200	2000
	3.3	3.7 [5]	6.5 [9]	D	0.06	0.7	2.5	2.5	5.0	ECSF1EE335()	200	2000
	4.7	4 [5.5]	7 [9]	E	0.06	1.0	2.5	2.5	5.0	ECSF1EE475()	200	2000
	6.8	4.5 [5.5]	7 [10]	F	0.06	1.4	2.5	2.5	5.0	ECSF1EE685()	200	2000
	10	5.2 [6]	8.5[11.5]	H	0.06	2.0	2.5	2.5	5.0	ECSF1EE106()	200	2000
	15	5.5 [6.5]	9.5[12.5]	I	0.06	3.0	2.5	2.5	5.0	ECSF1EE106()	200	2000
	22	6	11	J	0.06	4.4	2.5			ECSF1EE226()	200	
33	7.5	12.5	K	0.06	6.6	5.0			ECSF1EE336()	100		
35	0.1	3.3 [4.5]	5 [9]	A	0.04	0.05	2.5	2.5	5.0	ECSF1VE104()	200	2000
	0.15	3.3 [4.5]	5 [9]	A	0.04	0.05	2.5	2.5	5.0	ECSF1VE154()	200	2000
	0.22	3.3 [4.5]	5 [9]	A	0.04	0.07	2.5	2.5	5.0	ECSF1VE224()	200	2000
	0.33	3.3 [4.5]	5 [9]	A	0.04	0.1	2.5	2.5	5.0	ECSF1VE334()	200	2000
	0.47	3.3 [4.5]	5.5 [9]	B	0.04	0.2	2.5	2.5	5.0	ECSF1VE474()	200	2000
	0.68	3.3 [4.5]	5.5 [9]	B	0.04	0.2	2.5	2.5	5.0	ECSF1VE686()	200	2000
	1	3.5 [4.5]	5.5 [9]	C	0.04	0.3	2.5	2.5	5.0	ECSF1VE105()	200	2000
	1.5	3.5 [4.5]	5.5 [9]	C	0.06	0.5	2.5	2.5	5.0	ECSF1VE155()	200	2000
	2.2	3.7 [5]	6.5 [9]	D	0.06	0.7	2.5	2.5	5.0	ECSF1VE225()	200	2000
	3.3	4 [5.5]	7 [9]	E	0.06	1.0	2.5	2.5	5.0	ECSF1VE335()	200	2000
	4.7	4.5 [5.5]	7 [10]	F	0.06	1.4	2.5	2.5	5.0	ECSF1VE475()	200	2000
	6.8	5.2 [6]	8.5[11.5]	H	0.06	2.0	2.5	2.5	5.0	ECSF1VE685()	200	2000
	10	5.5 [6.5]	9.5[12.5]	I	0.06	2.8	2.5	2.5	5.0	ECSF1VE106()	200	2000
	15	6	11	J	0.06	4.2	2.5			ECSF1VE156()	200	
22	7.5	12.5	K	0.06	6.2	5.0			ECSF1VE226()	100		
50	0.1	3.3 [4.5]	5 [9]	A	0.04	0.05	2.5	2.5	5.0	ECSF1HE104()	200	2000
	0.15	3.3 [4.5]	5 [9]	A	0.04	0.06	2.5	2.5	5.0	ECSF1HE154()	200	2000
	0.22	3.3 [4.5]	5.5 [9]	B	0.04	0.09	2.5	2.5	5.0	ECSF1HE224()	200	2000
	0.33	3.5 [4.5]	5.5 [9]	C	0.04	0.2	2.5	2.5	5.0	ECSF1HE334()	200	2000
	0.47	3.7 [5]	6.5[9]	D	0.04	0.2	2.5	2.5	5.0	ECSF1HE474()	200	2000
	0.68	3.7 [5]	6.5[9]	D	0.04	0.3	2.5	2.5	5.0	ECSF1HE684()	200	2000
	1	4 [5.5]	7 [9]	E	0.04	0.4	2.5	2.5	5.0	ECSF1HE105()	200	2000
	1.5	4.5 [5.5]	7 [10]	F	0.06	0.6	2.5	2.5	5.0	ECSF1HE155()	200	2000
	2.2	4.7 [6]	8 [11]	G	0.06	0.9	2.5	2.5	5.0	ECSF1HE225()	200	2000
	3.3	5.2 [6]	8.5[11.5]	H	0.06	1.4	2.5	2.5	5.0	ECSF1HE335()	200	2000
4.7	5.5 [6.5]	9.5[12.5]	I	0.06	1.9	2.5	2.5	5.0	ECSF1HE475()	200	2000	

Suffix for the Part Numbers in ()

Capacitance Tolerance	Lead style	Bulk		Tapi ng	
		Straight Lead A~J Size : 2.5mm K Size : 5.0mm	Formed Lead A~J Size : 5.0mm K Size : N/A	Straight Lead A~I Size : 2.5mm J, K Size : N/A	Formed Lead A~I Size : 5.0mm J, K Size : N/A
± 20%		Not applicable	H	B1	BB
± 10%		K	KH	B2	2B

Diameter, length in brackets [] represent the formed lead type such as H,KH,BB,2B

When requesting taped product, please put the letter "B1" or "BB" between the "()".

Design, Specifications are subject to change without notice. Ask factory for technical specifications before purchase and/or use. Whenever a doubt about safety arises from this product, please inform us immediately for technical consultation without fail.