

DSF/FSO Series



- Up to 28 A Output Current
- Up to 500 W Output Power
- Active Surge Protection
- MIL-STD 461 and DEF-STAN 59-411
- MIL-STD 1275 and DEF-STAN 61-5
- MIL-STD 810
- 3 Year Warranty

Specification

Input

Input Voltage Range	• See Models & Ratings table
Input Transient	• ± 250 V for 70 μ s 2 J, 100 V for 50 ms 0.5 Ω per MIL-STD-1275A-E
Input Reverse Voltage Protection	• Continuous
Fuse Protection	• None

Output

Output Voltage	• Tracks input voltage & clamps <36 VDC
Output Power	• See Models & Ratings table
Output Module Inhibit (INH)	• Open collector transistor rated 70 VDC with 5 mA sink current referenced to -Vin/-Vout. When the output current is: >4 A: DSF100, >7.77 A: DSF200LV >28 A: DSF500 then the INH pin is pulled logic low. This can be used to inhibit downstream DC-DC converters and reduce the load on the filter. When the output current is lower than above the INH pin is logic high.
Overtemperature Protection	• Shuts down output by pulling disable pin low when baseplate >100 °C. Typical hysteresis 5 °C auto recovery

General

Efficiency	• See Table
Isolation Voltage	• 500 VDC Input & Output to Case
Series Resistance	• 0.07 Ω DSF100, 0.26 Ω DSF200LV, 0.018 Ω DSF500, 0.013 Ω FSO461
Disabled Input Current Disable (DIS)	• 25 mA • On = Logic high or open circuit Off = Logic low or short circuit
No Load Current	• 75 mA
Package Style	• Photo-etched nickel-silver case & aluminium cooling baseplate
MTBF	• DSF100: 2496 kHrs, DSF200LV: 2218 kHrs, DSF500: 573 kHrs, FSO461: 8737 kHrs, to MIL-HDBK-217F at 40 °C, GB

Environmental

Operating Temperature	• -40 °C to +100 °C baseplate
Storage Temperature	• -55 °C to +100 °C
Salt Atmosphere	• MIL-STD-810G method 509.4
Humidity	• MIL-STD-810G 507.4
Altitude	• MIL-STD-810G 500.4
Shock	• MIL-STD-810G 516.5 function test for ground equipment 40 g in 3 axes
Vibration	• MIL-STD-810G method 514.5C-17. Minimum integrity test for military equipment (1 Hr/axis, 3 axes). Vibration 5-33 Hz, 0.5 mm displacement

EMC & Safety

Safety Approvals	• CE & UKCA meets all applicable directives & legislation
Immunity	• MIL-STD-1275A-E, MIL-STD-461E/F/G (CS101, CS114, CS115 & CS116) MIL-STD-704A, DEF-STAN 61-5 part 6 issue 5 Contact Sales when DEF-STAN-61-5 part 6 issue 6 is required
EMC Performance	• DSF100 & DSF200LV: MIL-STD 461E/F CE102 & DEF STAN 59-411 DCE01/DCE02 is achieved with external components. DSF500: Compliance to MIL-STD 461E/F/G CE102 & DEF STAN 59-411 DCE01/DCE02 is achieved when used in conjunction with FSO461. See longform datasheet for more information.

Models & Ratings

Output Power	Input Voltage	Output		Typical Efficiency	Model Number
		Voltage	Max Current		
100 W	10-33 VDC	<36 VDC	3.7 A	98%	DSF100
30 - 54 W	10-18 VDC	<36 VDC	3.0 A	92%	DSF200 LV
126 - 230 W	18-33 VDC	<36 VDC	7.0 A	93%	
280 - 500 W	10-33 VDC	<36 VDC	28.0 A ⁽¹⁾	98%	DSF500 ⁽³⁾
500 W	0-100 VDC	$V_{in} - I_{in} \times 0.013$	28.0 A	99%	FSO461 ⁽²⁾

Notes

1. For input voltages above 18 V, maximum load is 500 W.
2. FSO461 has filter circuitry only. To be used with DSF500 for conducted immunity compliance.
3. DSF500 has surge protection only. To meet stated EMC performance it must be used with FSO461.

Mechanical Details

DSF100 - Surge protection and filter

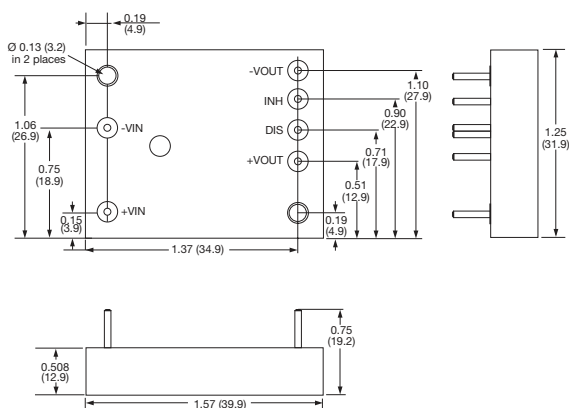

DSF200LV - Surge protection and filter

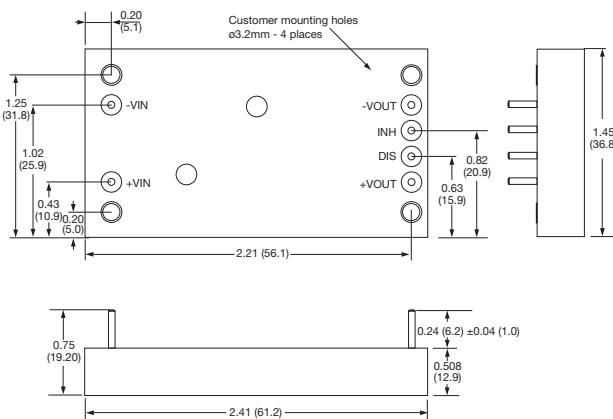

DSF500 - Surge protection

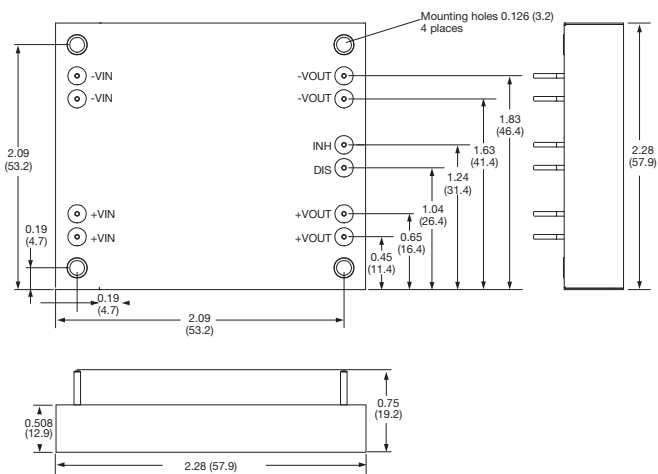

FSO461 - Filter

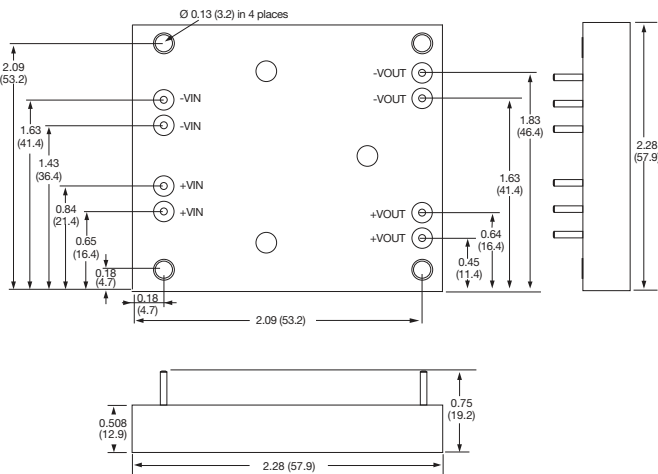

Notes

1. All dimensions in inches (mm).
2. Weights: DSF100: 0.11 lbs (50 g)
DSF200LV: 0.18 lbs (80 g)
DSF500: 0.36 lbs (160 g)
FSO461: 0.36 lbs (160 g)
3. Tolerance ±0.011 (±0.3). If using multiple modules, please consider variations in module tolerances.
4. Pin diameter 0.04 (1.0)
5. Pin Material: Copper - tin alloy
Finish: 2.5 μ copper and 2.5 μ Sn (tin)