

## Sensitivity Wavelength Range: 600nm ~ 1750nm

The 1346 series from Marktech, a high sensitivity and high reliability product series, is ideally suited for Optical Communication devices. Custom packaging options for this die are also available.

### FEATURES

- > High Speed Response (Max: 2Gbps)
- > Seam Welded Surface Mount Package
- > Active Area of 1.0mm / High Sensitivity
- > Spectral Range: 600nm - 1750nm

### APPLICATIONS

- > High Speed Optical Communications
- > Industrial Controls
- > Optical Switches
- > LIDAR
- > Medical

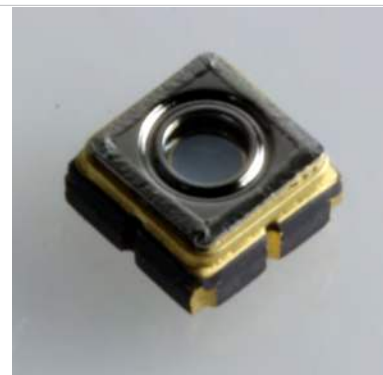

## Absolute Maximum Ratings (Ta=25°C)

ITEMS	SYMBOL	RATINGS	UNIT
Active Area	$\Phi$	1.0	mm
Operating Temperature Range	T <sub>opr</sub>	-40 to +85	°C
Storage Temperature Range	T <sub>stg</sub>	-40 to +125	°C

## Electrical & Optical Characteristics (Ta = 25°C)

ITEMS	SYMBOL	CONDITIONS	MIN	TYP	MAX	UNIT
Breakdown Voltage	VR	IR=10uA	--	--	3	V
Sensitivity Range	$\lambda$	VR=0V	600	--	1750	nm
Dark Current	ID	VR=1V	--	--	2.0	uA
Junction Capacitance	C	VR=0V	--	60	--	pF
Light Current @1300nm *1	IL	$\lambda$ =1300nm; *2	--	180	--	uA
Responsivity	R	$\lambda$ =1550nm	--	0.70	--	A/W
Quantum Efficiency	QE	$\lambda$ =1660nm	--	55	--	%
Shunt Resistance	RSH	VR=10mV	--	2	--	M $\Omega$
Switching Times	Tr, Tf	VR=2V	--	0.63	--	ns

\*1: As mounted on TO-46 header without resin coating. \*2: VR=2V

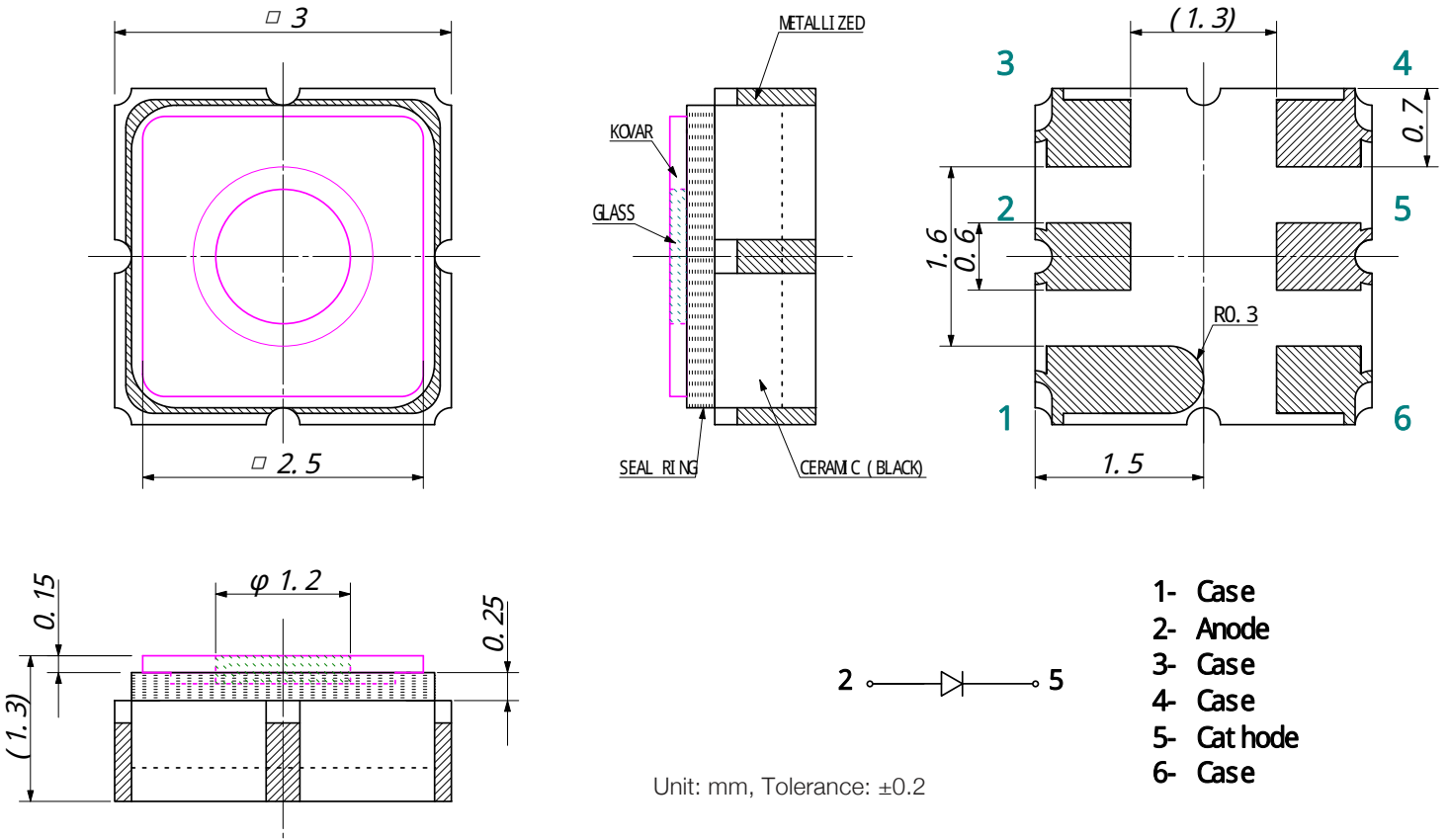

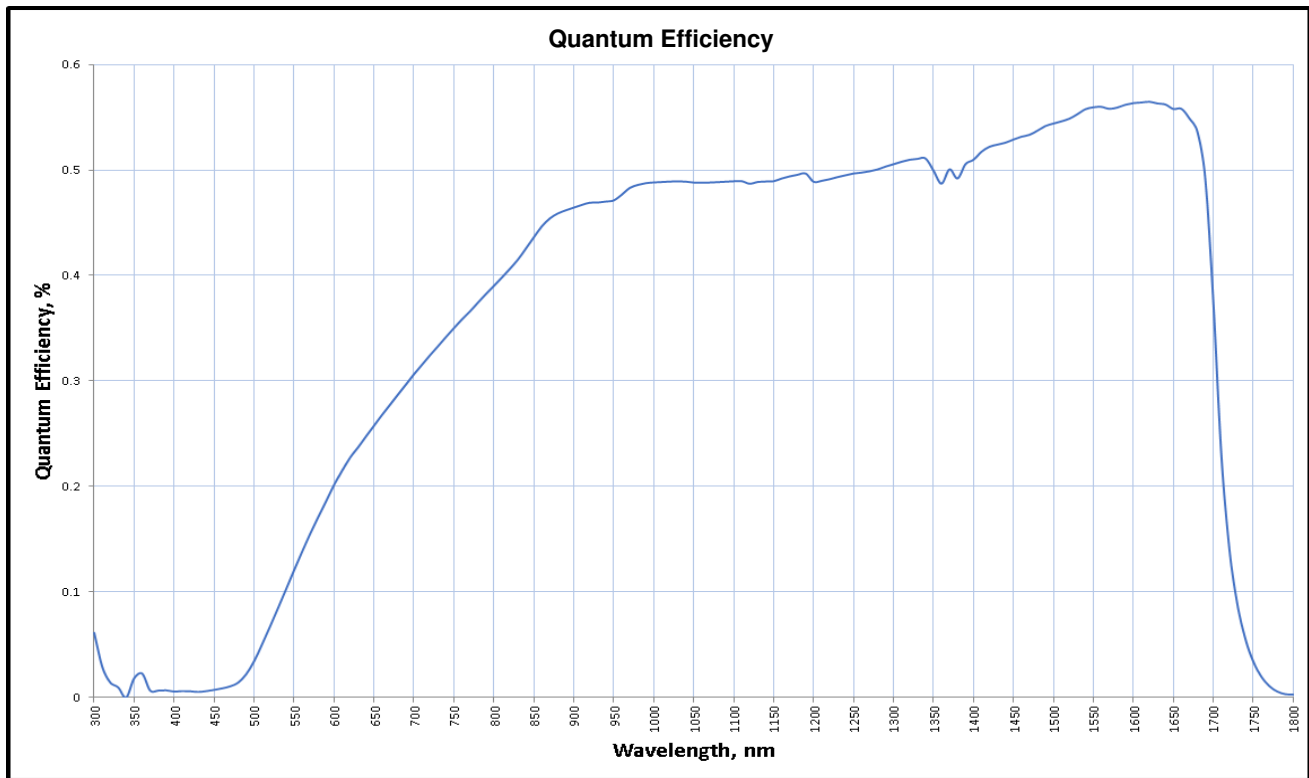
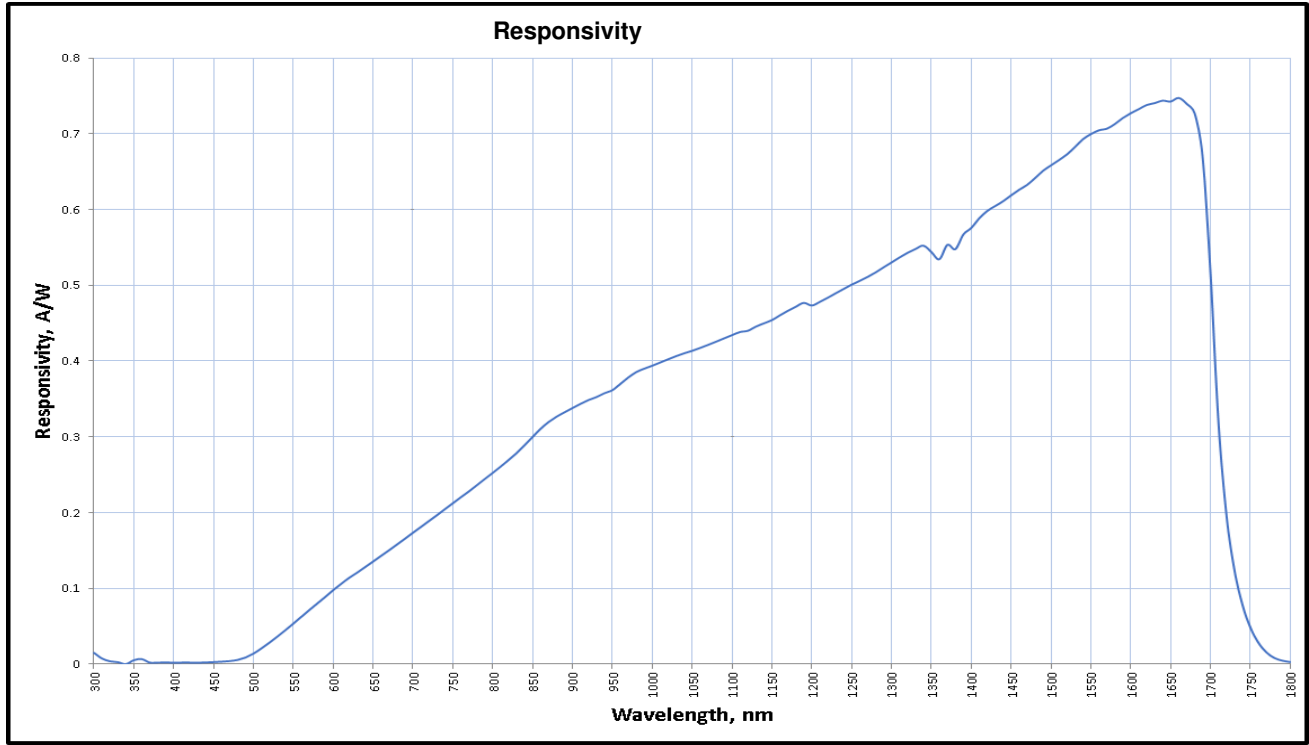

The information contained herein is subject to change without notice.

2022-12-08