

# **Instruction manual for Evaluation Board - TB67S249FTG -**

January 18th, 2018

Rev.1.0

## 【Outline】

The TB67S249FTG is a two-phase bipolar stepping motor driver using a PWM chopper. CLK-IN control system and BiCD process are adopted. Rating of 50 V and 4.5 A is realized.

This evaluation board mounts necessary components to evaluate the IC. Each excitation mode of full step, half step, quarter step 1/8 step, 1/16 step, and 1/32 step is possible with PWM constant current drive. Please sense low-noise and low-vibration drive of stepping motors applying the TB67S249FTG.

## 【Note】

In using, please be careful about the thermal condition sufficiently. As for each control signal, please refer to the IC specification by accessing to the below URL.

<http://toshiba.semicon-storage.com/eu/product/linear/motordriver/detail.TB67S249FTG.html>

Further, the application of this evaluation board is limited to the purpose of evaluating and learning the motor control. Please do not ship them to a market.

# Connection to evaluation board

## Corresponding table (Silk name vs. Signal name)

(Note) Each silk name and signal name on the board is different because the boards for the series products are common.

Silk name	Signal name
39	DMODE0
40	DMODE1
41	DMODE2
42	CW/CCW
43	CLK
44	ENABLE
45	RESET
46	MO
47	LO1
48	LO2

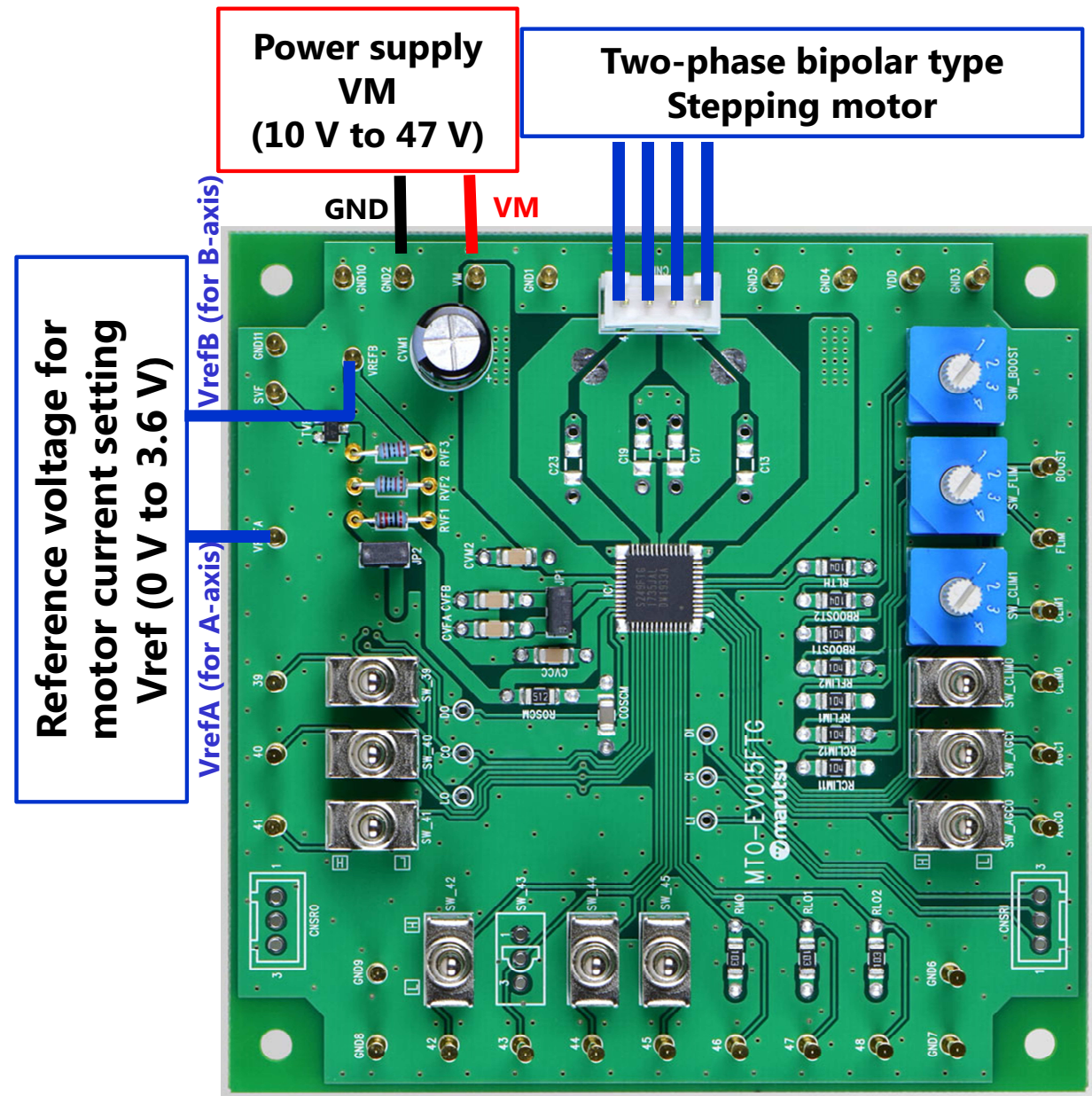

# Setting evaluation board 1

## Setting motor current

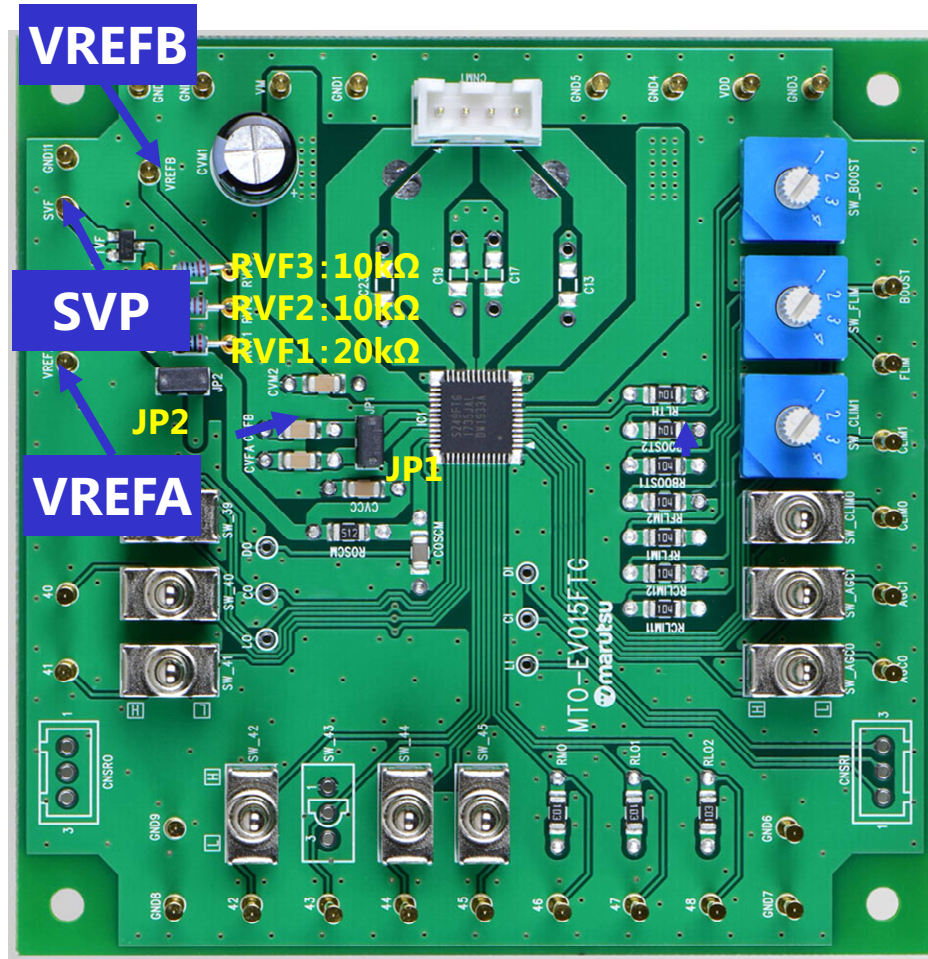

## Setting motor current

$$I_{out} (\text{max}) = VREF (\text{V}) \times 1.25$$

Resistors of RVF1 (20 kΩ), RVF2 (10 kΩ), and RVF3 (10kΩ) are mounted. Jumpers of JP1 and JP2 are connected.

Therefore, in the initial state, each voltage for VREFA and VREFB is supplied by dividing the VCC voltage.

When SVP pin is connected to GND, the VREF voltage is about 1.67 V. When SVP pin is connected to VCC (5 V), the VREF voltage is about 1 V.

Select the resistor between RVF1, RVF2, and RVF3 according to the usage conditions.

When supplying the external voltage to VREF, disconnect resistors (RVF1, RVF2, and RVF3). When supplying different voltage to VREFA and VREFB, disconnect the short-pin of JP1.

## Waveform of motor current

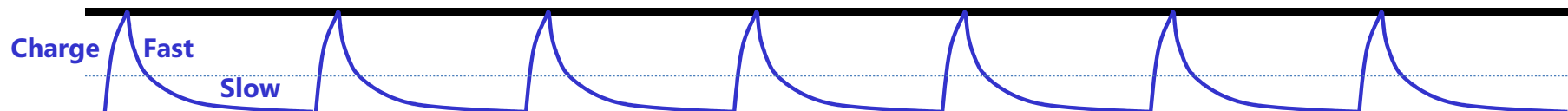

## Current value of setting motor



# Setting evaluation board 2

## Setting chopping frequency of the constant current of the motor

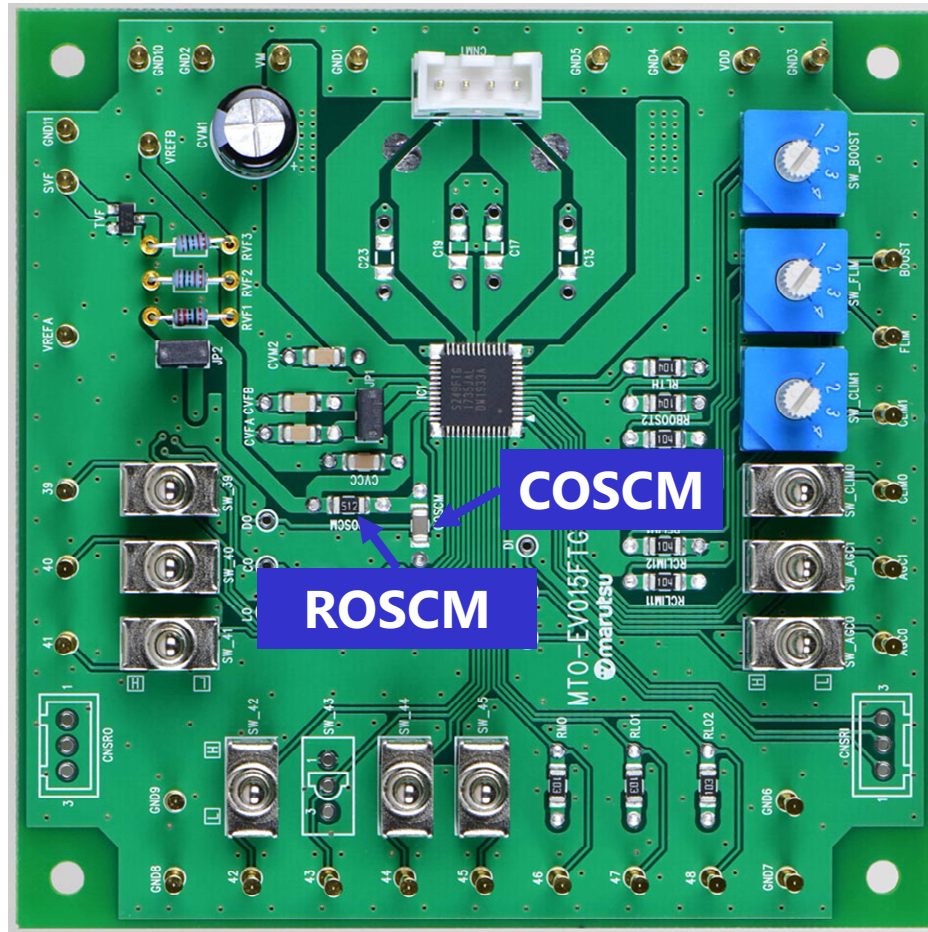

### Formula of setting chopping frequency

$$f_{OSCM} \text{ [MHz]} = 4.0 \times ROSC \text{ [k}\Omega\text{]}^{(-0.8)}$$

$$f_{chop} = f_{OSCM} / 16$$

COSC = 270 pF (fix)

Mounted components are as follows;

Capacitor (OSCM=270 pF)

Resistor (ROSCM=5.1 kΩ)

### Waveform of motor current

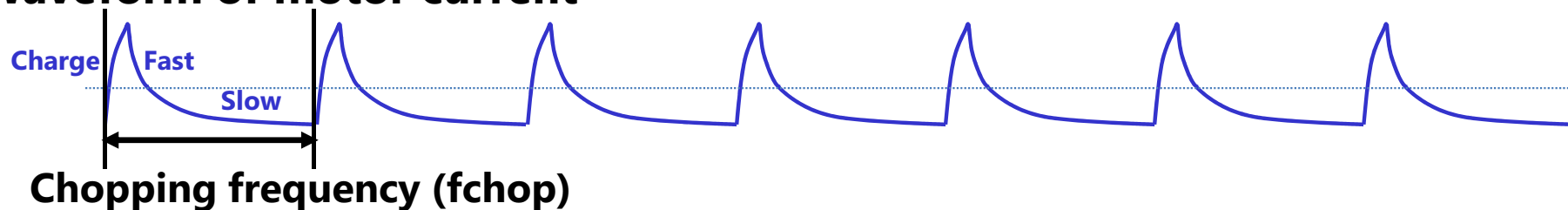

# Setting evaluation board 3

## Setting motor operation

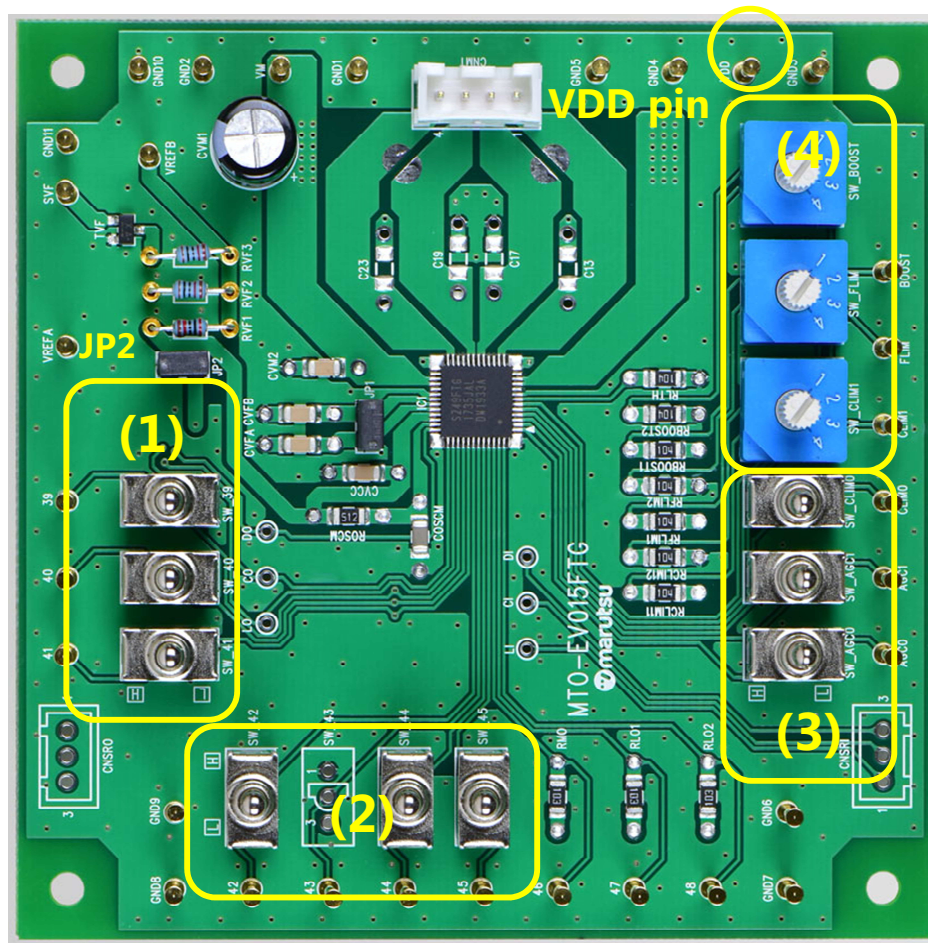

Three-position toggle switches ((1), (2), and (3) in the left diagram) for setting the operation of the TB67S249FTG and a rotary switch ((4) in the left figure) for adjusting the AGC function are mounted. In using these switches, short-circuit the jumper of JP2 (i.e. initialize) or supply 5-V voltage from the VDD pin.

**【Switches of (1) and (3)】**  
Tilting rightward: Low level  
Tilting leftward: High level  
Middle position Neutral. The input signal from the pins is valid.

**【Switch of (2)】**  
Tilting downward: Low level  
Tilting upward: High level  
Middle position: Neutral. The input signal from the pins is valid.

**【Switch of (4)】**  
Four states can be selected by this rotary switch.  
Position 1: Connecting to VDD.  
Position 2: Connecting to VDD through a resistor of 100 k $\Omega$ .  
Position 3: Connecting to GND through a resistor of 100 k $\Omega$ .  
Position 4: Connecting to GND.

※Refer to the datasheet for information on how to use and set each function.

# Circuit of evaluation board

