

THIS DRAWING IS UNPUBLISHED. RELEASED FOR PUBLICATION  
 © COPYRIGHT - By - ALL RIGHTS RESERVED.

LOC		DIST		REVISIONS			
P	LTR	DESCRIPTION		DATE	DWN	APVD	
GP	00	L	REVISED PER ECO-14-011808	12AUG2014	AP	SB	

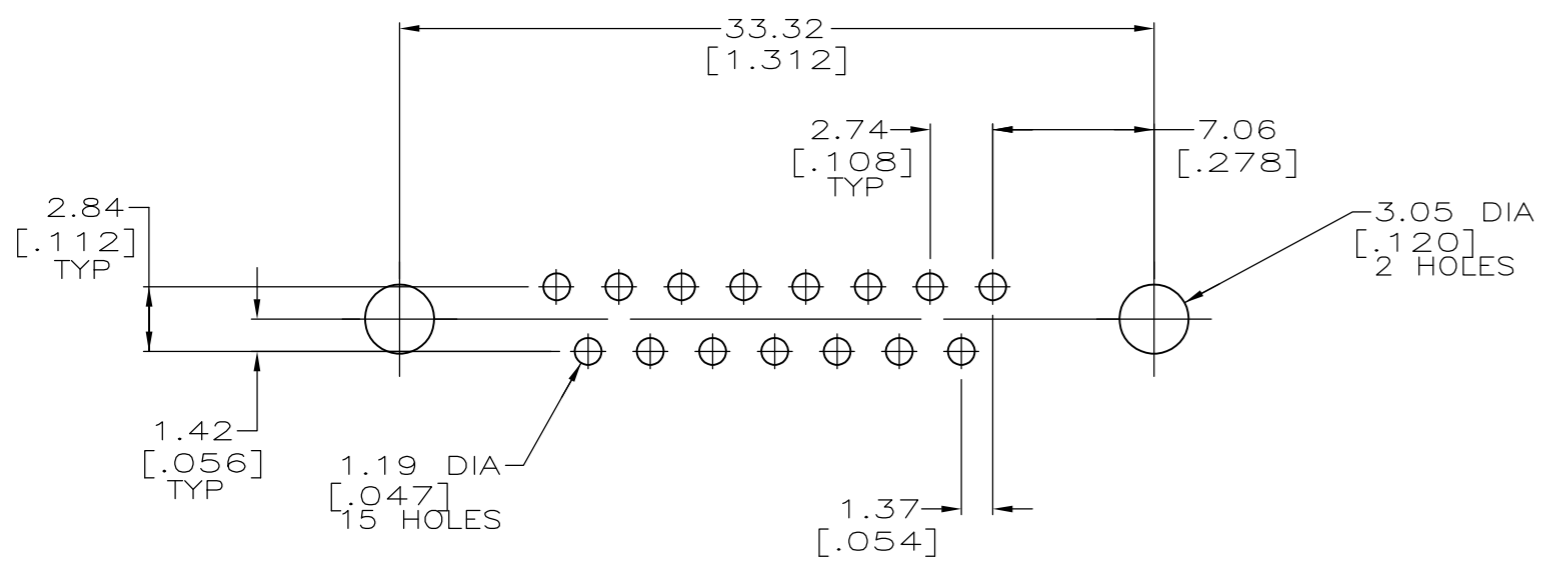
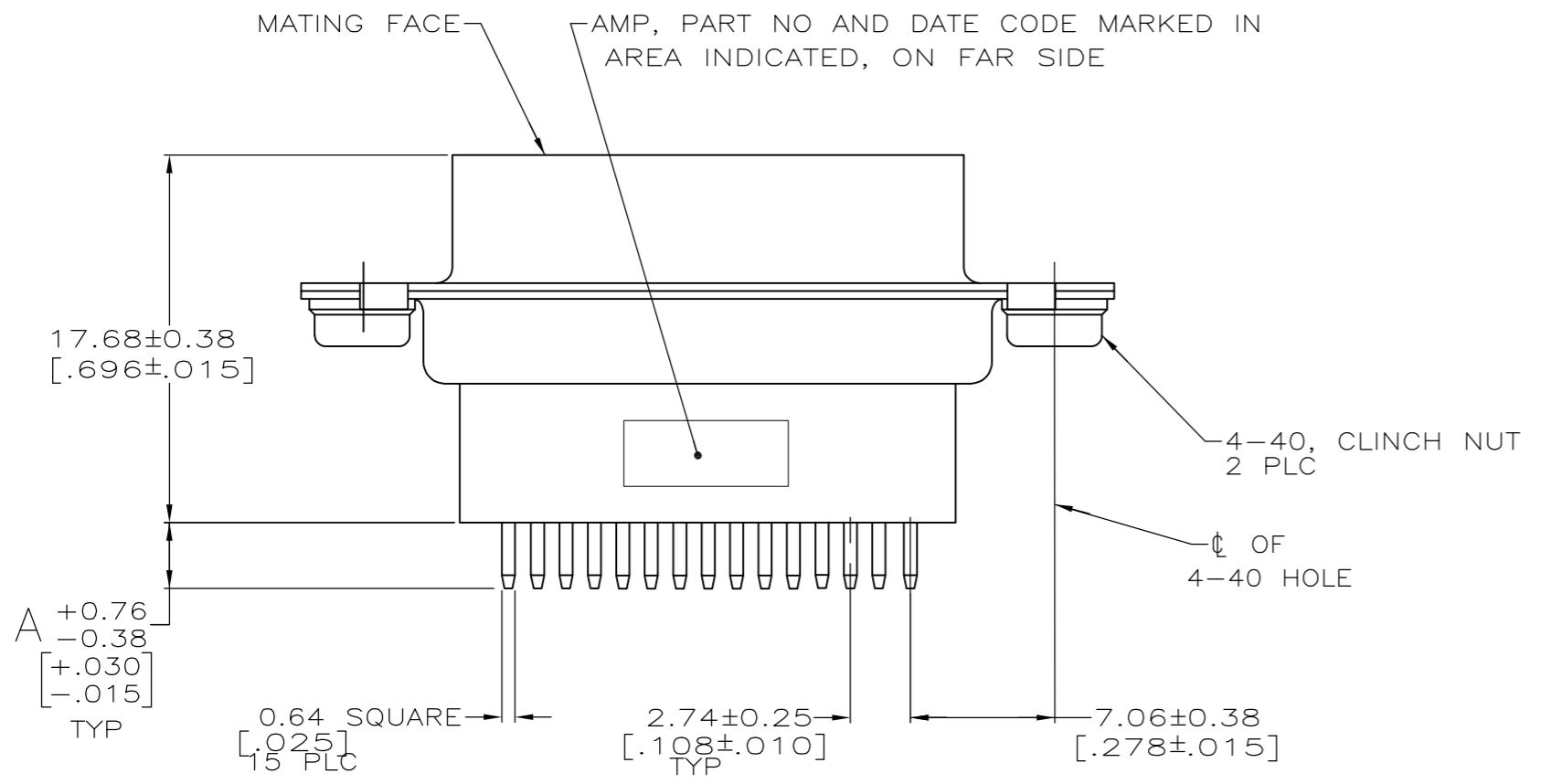
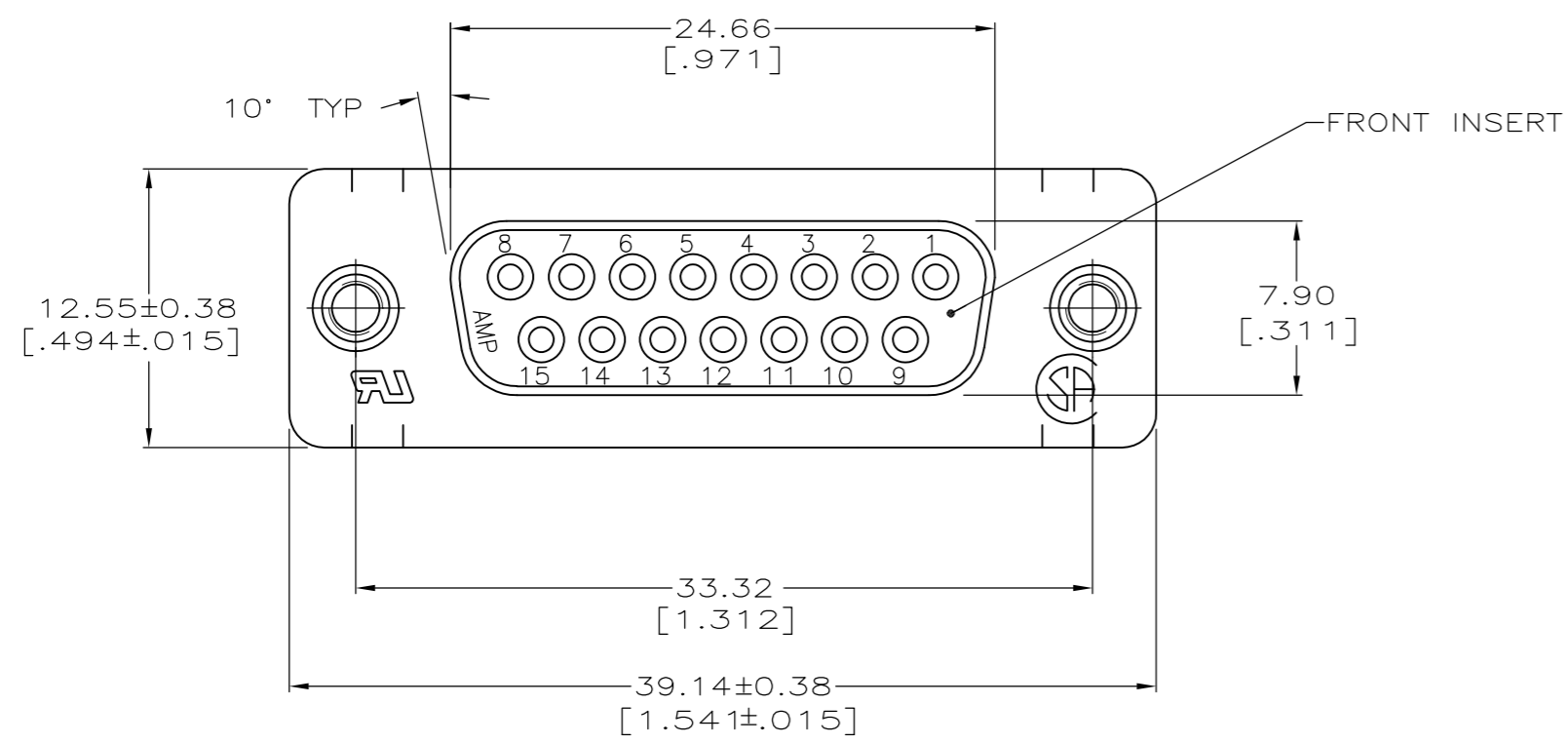

RECOMMENDED PC BOARD MOUNTING DIMENSIONS

- ① HOUSING: GLASS-FILLED PBT OR GLASS-FILLED NYLON, UL94V-0 RATED. COLOR: BLACK.  
 CONTACTS: PHOSPHOR BRONZE  
 SHELLS: CARBON STEEL  
 CLINCH NUT: CARBON STEEL
- ② GOLD FLASH FOR LENGTH OF 2.54 [.100] MIN FROM MATING END, 2.54µm [.000100] MIN TIN OR TIN-LEAD FOR A LENGTH OF DIMENSION A FROM OPPOSITE END, BOTH OVER 1.27µm [.000050] MIN NICKEL.
- ③ 0.76µm [.000030] MIN GOLD FOR LENGTH OF 2.54 [.100] MIN FROM MATING END, 2.54µm [.000100] MIN TIN OR TIN-LEAD FOR A LENGTH OF DIMENSION A FROM OPPOSITE END, BOTH OVER 1.27µm [.000050] MIN NICKEL.  
 -OR-  
 GOLD FLASH OVER PALLADIUM-NICKEL, 0.76µm [.000030] MIN TOTAL, FOR A LENGTH OF 2.54 [.100] MIN FROM MATING END, 2.54µm [.000100] MIN TIN OR TIN-LEAD FOR A LENGTH OF DIMENSION A FROM OPPOSITE END, BOTH OVER 1.27µm [.000050] MIN NICKEL.
- ④ SHELLS: 5.08µm [.000200] MIN TIN OVER 2.54µm [.000100] MIN COPPER  
 CLINCH NUT: ZINC

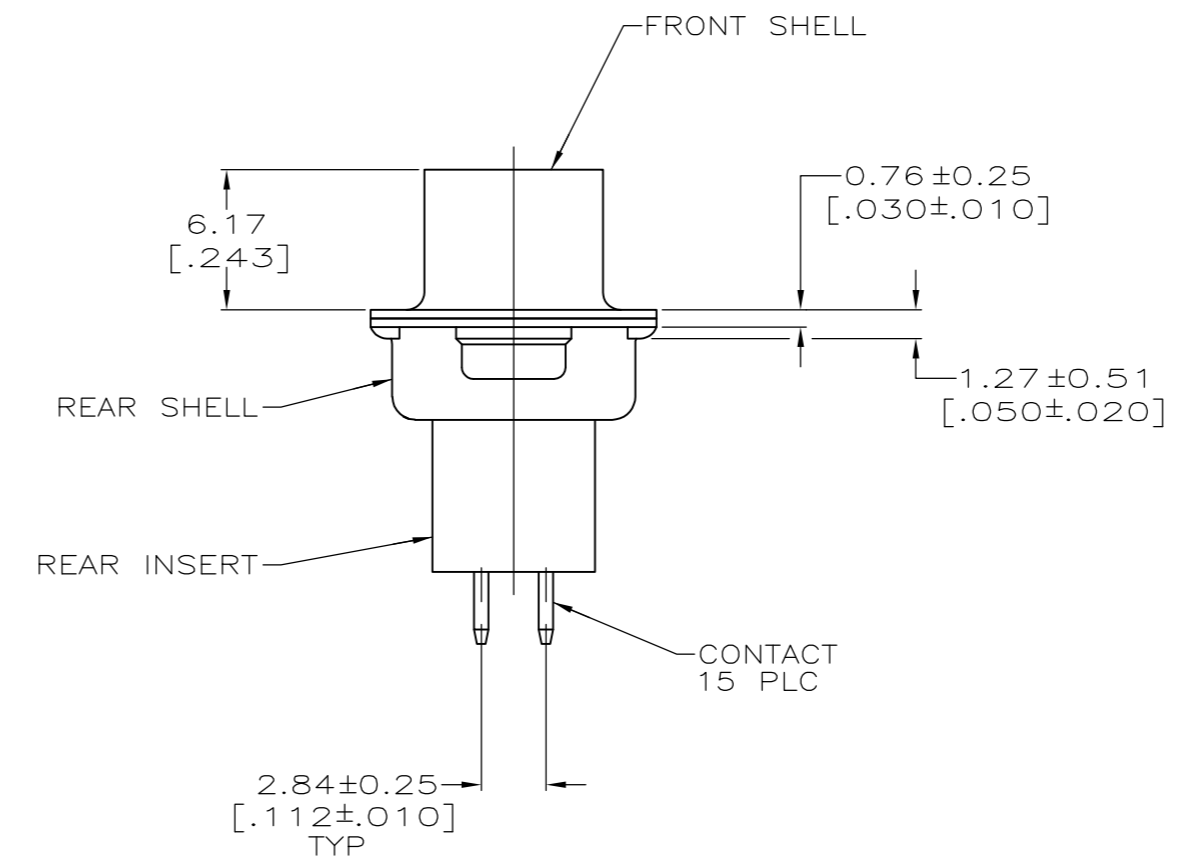

SUPSD BY	THICKNESS	FINISH	PART NUMBER
SUPSD BY 745820-1	4.78 [.188]	②	745820-8
OBSOLETE	4.78 [.188]	③	745820-7
OBSOLETE	16.54 [.651]	②	745820-6
OBSOLETE	16.54 [.651]	③	745820-5
SUPSD BY 745820-1	10.85 [.427]	②	745820-4
SUPSD BY 745820-1	10.85 [.427]	③	745820-3
	3.18 [.125]	②	745820-2
	3.18 [.125]	③	745820-1
	DIMENSION A	CONTACT FINISH	PART NUMBER

THIS DRAWING IS A CONTROLLED DOCUMENT.		DWN	J.McCLINTON	12-05-89	 TE Connectivity RECEPTACLE ASSEMBLY, SIZE 2, 15 POSN, VERTICAL, FRONT METAL SHELL, AMPLIMITE® HD-20
DIMENSIONS: mm [INCHES]		CHK	R.STONE	02-01-90	
TOLERANCES UNLESS OTHERWISE SPECIFIED:		APVD	C. ROHDE	2-02-90	
0 PLC ± - 1 PLC ± - 2 PLC ± 0.13 [.005] 3 PLC ± - 4 PLC ± - ANGLES ± 2°		PRODUCT SPEC	108-40025	APPLICATION SPEC	
MATERIAL	FINISH	WEIGHT	114-40013	SIZE	A2
CONTACTS: SEE TABLE	CUSTOMER DRAWING	SCALE	NTS	SHEET	1 OF 1