



- 1
- 2
- 3
- 4
- 5
- 6
- 7
- 8
- 9
- 10
- 11
- 12
- 13
- 14
- 15
- 16
- 17
- 18

MATERIAL

Glass-fibre reinforced polyamide based (PA) technopolymer, RAL 5005 blue colour, matte finish.

Produced from FDA compliant raw material (FDA CFR.21 and EU 10/2011).

STANDARD EXECUTION

ANSI 303 stainless steel bosses, threaded holes.

FEATURES AND APPLICATIONS

The RAL 5005 blue colour is easily visible in case of accidental food contamination.

Particularly suitable for applications in the food and pharmaceutical industries.

TECHNICAL DATA

Tensile stress and impact strength: F1, F2, L1 and L2 values reported in the table are the result of breaking tests carried out with the appropriate dynamometric equipment under the test conditions shown in the figure with ambient temperature.



ELESA Original design

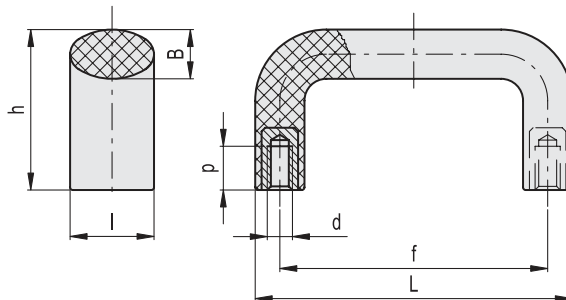
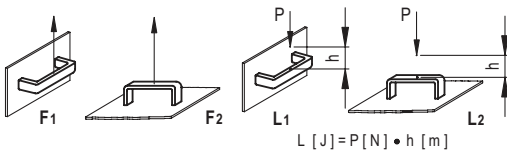

Conversion Table	
1 mm = 0.039 inch	
mm	inch
134	5.28
196	7.72



Code	Description	L	f	d6H	h	B	l	p	F1 [N]	F2 [N]	L1 [J]	L2 [J]	⚖️
194113	M.643/140-117-SST-M8-VD	134	117±0.5	M8	49	15	25	13	3500	4500	8	12	67
194153	M.643/200-SST-M8-VD	196	179±1	M8	57	16	27	13	2500	3000	11	15	130