

## Description

The HXR45400 is a low-power, single-ended input, quad channel linear Trans-Impedance Amplifier (TIA) array, and a member of the Optical Receiver Transmitter Array (ORTA) product family. Together with an array of PIN detectors or a group of discrete detectors, the HXR45400 can be used to design a compact linear ROSA for the next generation 400G/800G optical transceivers with advanced modulation schemes.

This TIA operates from a 3.3V supply, providing exceptionally low input referred noise density, wide input optical power range, excellent linearity up to 3mA overload, and a high bandwidth, while consuming as low power with the patented adaptive biasing scheme.

## Features

- High receiver sensitivity for up to 112Gbps PAM4 Ethernet
- Up to 5kΩ typical differential gain
- From 150mVppd to 500mVppd adjustable output voltage swing
- Linear operation with internal AGC
- 190mW per channel power consumption
- 13pA/VHz typical input referred current noise density
- 40GHz typical bandwidth
- High overload input current: 3mAppSE
- Accurate channel RSSI
- 100G Lambda MSA and IEEE 802.3bs and cd compliance
- Optimized for isolated and common cathode photo-detector arrays from multiple vendors

## Typical Applications

- Next-generation Ethernet optical receiver modules: 400G QSFP-DD, OSFP and OBO
- 400G Linear LR ROSA

## Block Diagram

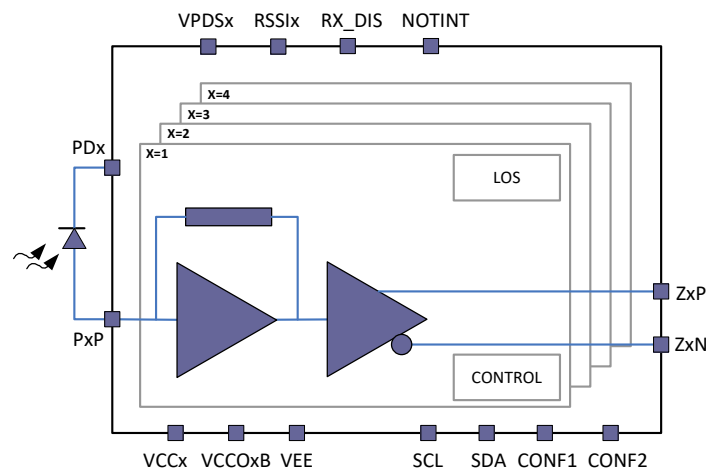

Figure 1: Block diagram

**Corporate Headquarters**

6024 Silver Creek Valley Road  
San Jose, CA 95138  
[www.IDT.com](http://www.IDT.com)

**Sales**

1-800-345-7015 or  
408-284-8200  
Fax: 408-284-2775  
[www.IDT.com/go/sales](http://www.IDT.com/go/sales)

**Tech Support**

[www.IDT.com/go/support](http://www.IDT.com/go/support)

DISCLAIMER Integrated Device Technology, Inc. (IDT) and its affiliated companies (herein referred to as "IDT") reserve the right to modify the products and/or specifications described herein at any time, without notice, at IDT's sole discretion. Performance specifications and operating parameters of the described products are determined in an independent state and are not guaranteed to perform the same way when installed in customer products. The information contained herein is provided without representation or warranty of any kind, whether express or implied, including, but not limited to, the suitability of IDT's products for any particular purpose, an implied warranty of merchantability, or non-infringement of the intellectual property rights of others. This document is presented only as a guide and does not convey any license under intellectual property rights of IDT or any third parties.

IDT's products are not intended for use in applications involving extreme environmental conditions or in life support systems or similar devices where the failure or malfunction of an IDT product can be reasonably expected to significantly affect the health or safety of users. Anyone using an IDT product in such a manner does so at their own risk, absent an express, written agreement by IDT.

Integrated Device Technology, IDT and the IDT logo are trademarks or registered trademarks of IDT and its subsidiaries in the United States and other countries. Other trademarks used herein are the property of IDT or their respective third party owners. For datasheet type definitions and a glossary of common terms, visit [www.idt.com/go/glossary](http://www.idt.com/go/glossary). All contents of this document are copyright of Integrated Device Technology, Inc. All rights reserved.