

### Absolute maximum ratings

( $T_a=25^\circ\text{C}$ )

Symbol	Ratings	Unit
$V_{CBO}$	-50	V
$V_{CEO}$	-50	V
$V_{EBO}$	-6	V
$I_C$	-4	A
$I_{CP}$	-8 (PW $\leq$ 10ms, Du $\leq$ 50%)	A
$P_T$	3 ( $T_a=25^\circ\text{C}$ )	W
	15 ( $T_c=25^\circ\text{C}$ )	
$T_j$	150	$^\circ\text{C}$
$T_{stg}$	-40 to +150	$^\circ\text{C}$

### Electrical characteristics

( $T_a=25^\circ\text{C}$ )

Symbol	Specification			Unit	Conditions
	min	typ	max		
$I_{CBO}$			-100	$\mu\text{A}$	$V_{CB}=-50\text{V}$
$I_{EBO}$			-10	mA	$V_{EB}=-6\text{V}$
$V_{CEO}$	-50			V	$I_C=-10\text{mA}$
$h_{FE}$	1000				$V_{CE}=-4\text{V}$ , $I_C=-3\text{A}$
$V_{CE(sat)}$			-2.0	V	$I_C=-3\text{A}$ , $I_B=-10\text{mA}$
$t_{on}$		0.4		$\mu\text{s}$	$V_{CC}=-30\text{V}$ , $I_C=-3\text{A}$ , $I_{B1}=-I_{B2}=-10\text{mA}$
$t_{stg}$		0.8		$\mu\text{s}$	
$t_f$		0.6		$\mu\text{s}$	

### Equivalent circuit diagram

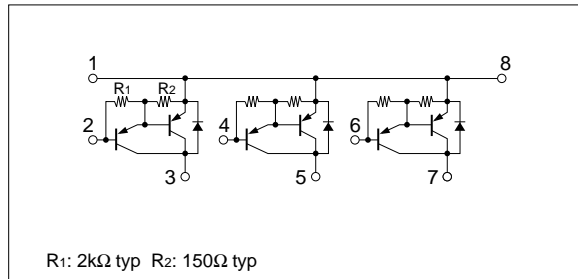

**$I_C$ - $V_{CE}$  Characteristics (Typical)**

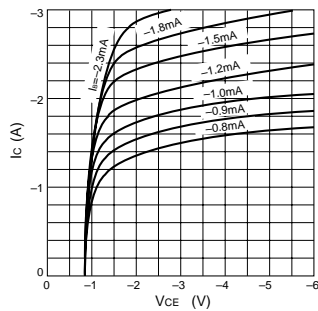

**$h_{FE}$ - $I_C$  Characteristics (Typical)**

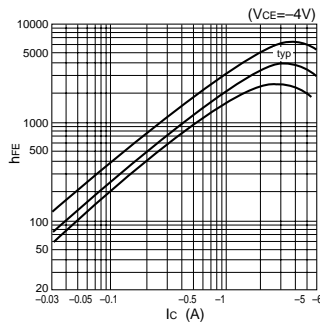

**$h_{FE}$ - $I_C$  Temperature Characteristics (Typical)**

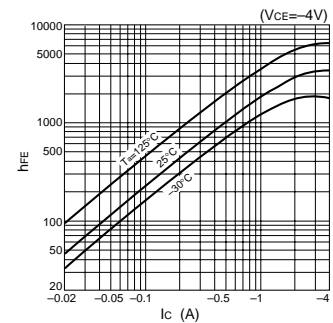

**$V_{CE(sat)}$ - $I_C$  Temperature Characteristics (Typical)**

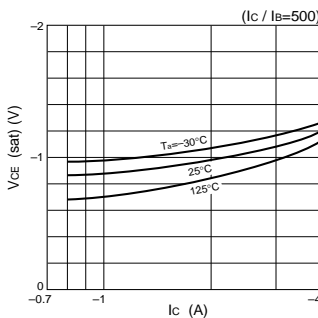

**$V_{CE(sat)}$ - $I_B$  Characteristics (Typical)**

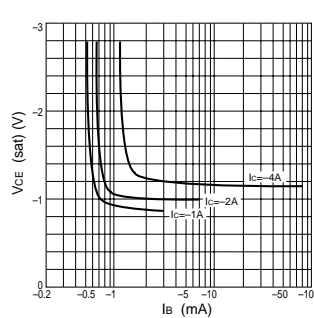

**$I_C$ - $V_{BE}$  Temperature Characteristics (Typical)**

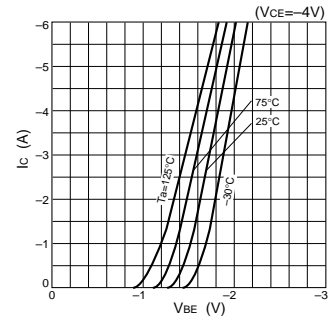

**$\theta_{j-a}$ -PW Characteristics**

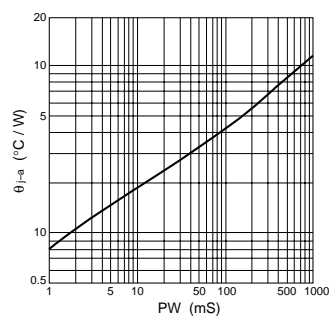

**$P_T$ - $T_a$  Characteristics**

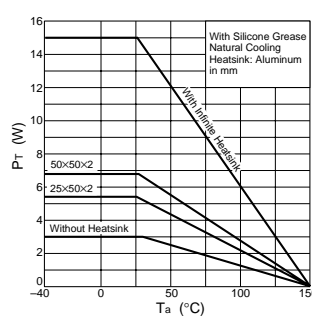

**Safe Operating Area (SOA)**

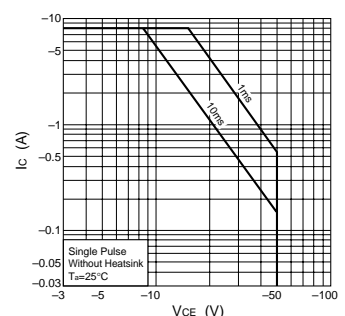

• SIP 8 (STA8Pin)

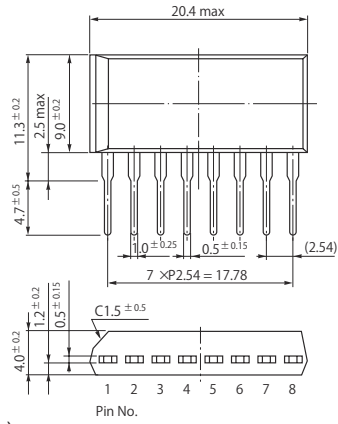

• SIP 10 (STA10Pin)

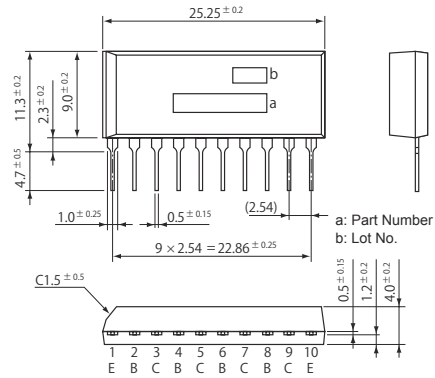

• SIP 12 (SMA12Pin)

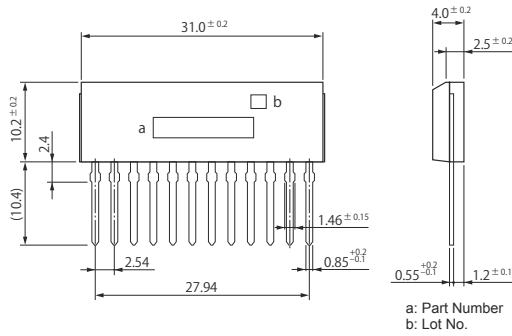

• SIP 15 (SMA15Pin)

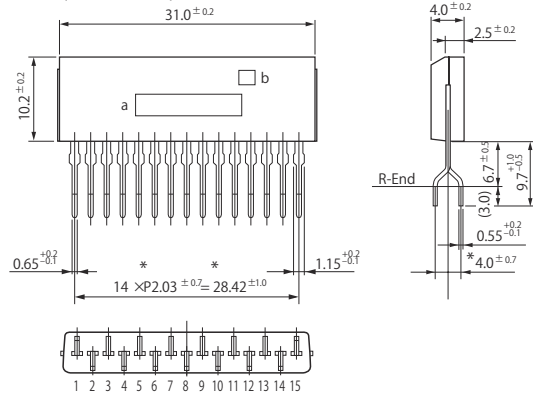

• SIP 12 with Fin (SLA12Pin)

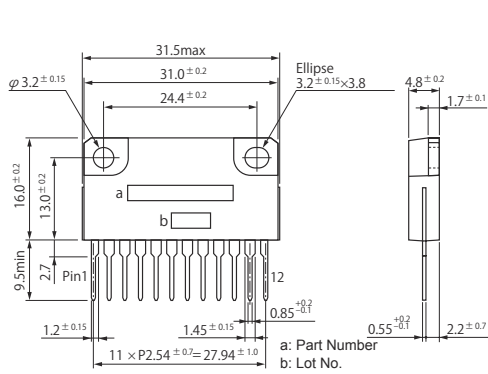

• SIP 15 with Fin (SLA15Pin)

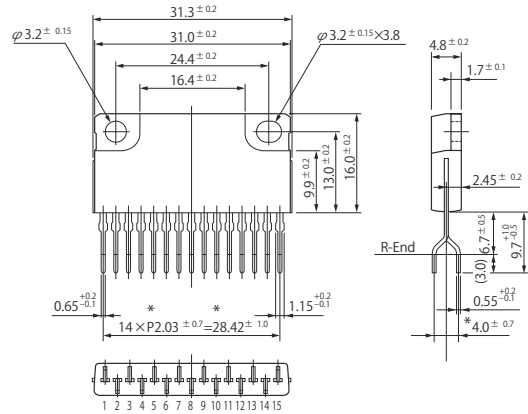

• SIP 21 with Fin (SLA21Pin)

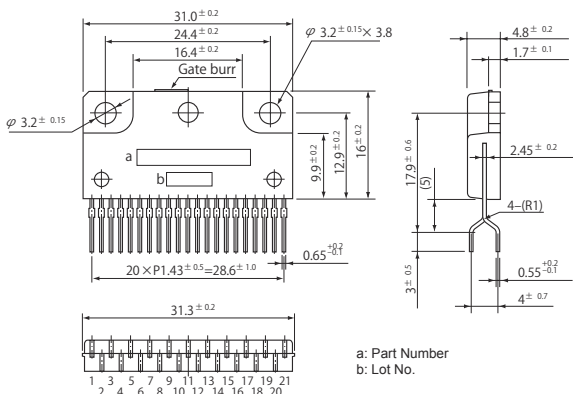

(Unit:mm)