

DESCRIPTION

Demonstration circuit 511 shows how a power supply's conducted and radiated EMI can be reduced significantly by using the LT3439 to control the voltage and current slew rates of its internal power switches. DC511 employs a push-pull topology which is inherently less noisy than most other topologies and the high frequency EMI is reduced by as much as 40dB by slewing the switching currents and voltages. The design is well suited to noise sensitive systems such as medical instruments, industrial sensing and control, data conversion and wide band communications.

DC511 produces isolated 12V_{out} and -12V_{out} at up to 80mA each from 5V_{in}. The board can be modified, by changing the transformer, to produce output voltages less than the input voltage. Output voltage regulation is directly proportional to input voltage regulation since there is no output feedback. DC511 uses a potentiometer that sets the slew rates of the power switches, allowing the user to observe the benefit of slew rate control, and to examine the tradeoff between noise performance and circuit efficiency.

Design files for this circuit board are available. Call the LTC factory.

QUICK START PROCEDURE

DC511 is easy to set up to evaluate the performance of the LT3439. Refer to Figure 1 for proper measurement equipment setup and follow the procedure below:

1. Connect Load 1 between the +V_{out} (E2) and Gnd (E3) terminals and another Load 2 between the -V_{out} (E4) and Gnd (E3) terminals.
2. Apply 5V between the Vin (E1) and Gnd (E6) terminals.
3. To measure the output noise, connect one end of a BNC cable to the BNC connector J1. Connect the other end of the BNC cable to an oscilloscope with a 50Ω input impedance. Refer to Application Note AN70 for more precise techniques for measuring the output noise.

QUICK START GUIDE FOR DEMONSTRATION CIRCUIT DC511

LOW NOISE SWITCHING POWER SUPPLY

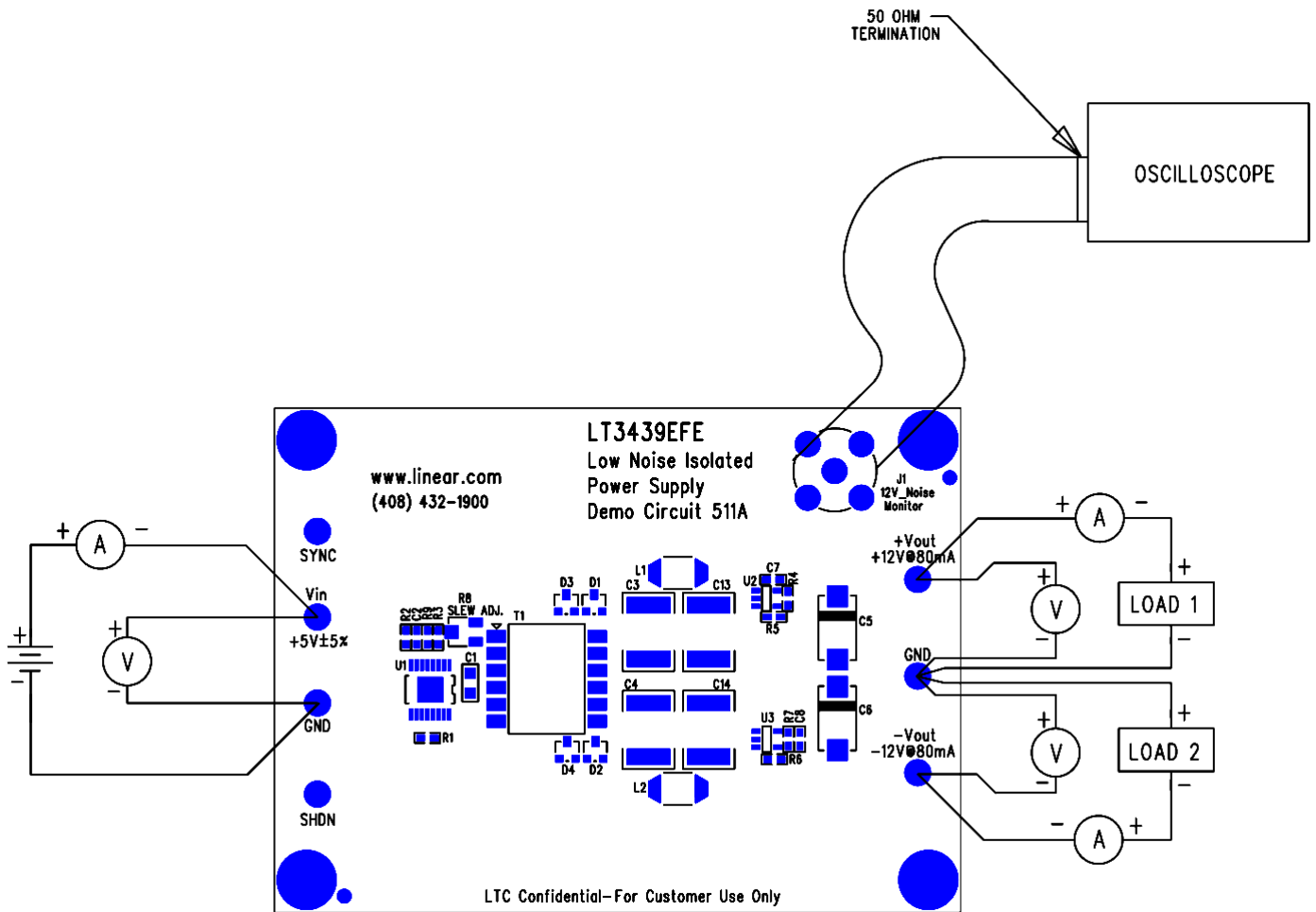
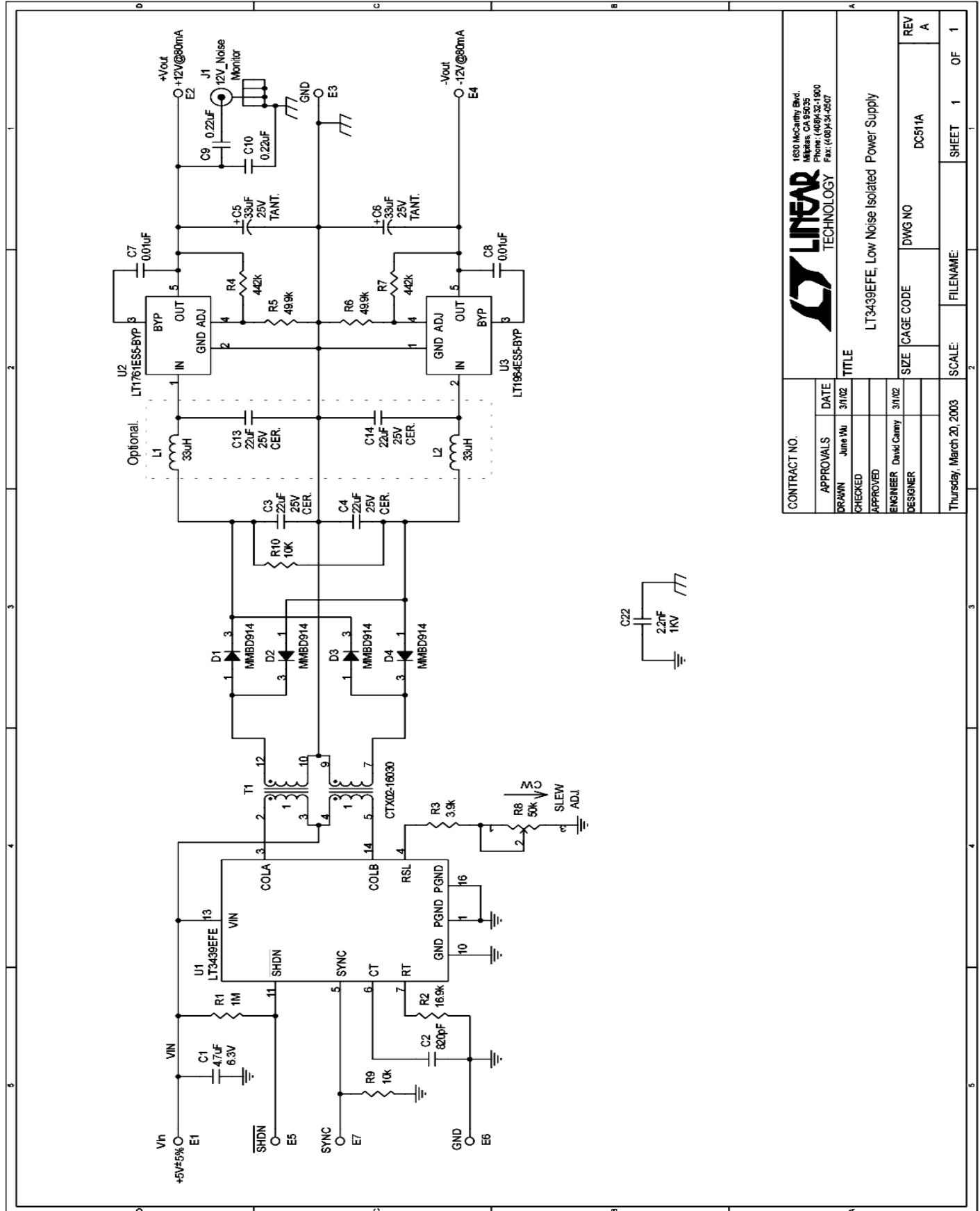

Figure 1. Proper Measurement Equipment Setup

QUICK START GUIDE FOR DEMONSTRATION CIRCUIT DC511

LOW NOISE SWITCHING POWER SUPPLY



CONTRACT NO.		1630 McCarthy Blvd. Milpitas, CA 95035 Phone: (408)432-1900 Fax: (408)434-6507	
APPROVALS	DATE	TITLE	
DRAWN	June Wu	LT3439EFE, Low Noise Isolated Power Supply	
CHECKED		SIZE	CAGE CODE
APPROVED			DWG NO
ENGINEER	David Canney		DC511A
DESIGNER			REV
			A
Thursday, March 20, 2003		SCALE:	FILENAME:
		SHEET	1 OF 1

