

REVISIONS					
REV	ECO	DESCRIPTION	DATE	BY	APPR
A1	-	RELEASED DRAWING	Mar-18-2016	Ben	Tommy
A2	-	UPDATE NOTES	Jun-20-2017	Nick	Tommy
A3	-	UPDATE DRAWING	Mar-19-2018	White	Tommy
A4	-	UPDATE DESCRIPTION	Jan-7-2021	Blink	Tommy

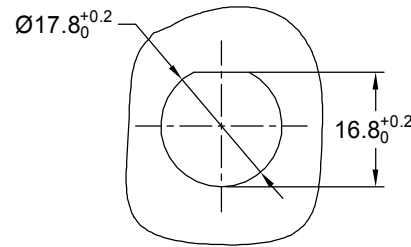
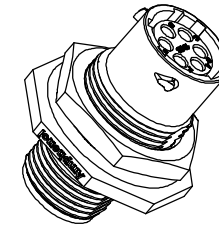
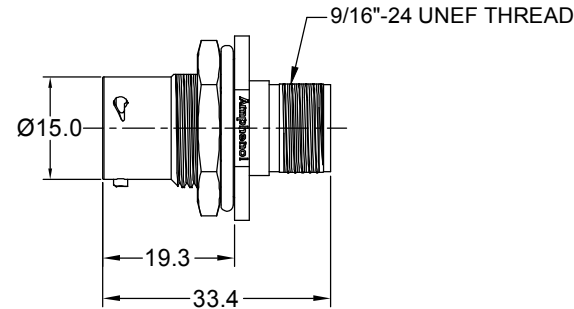
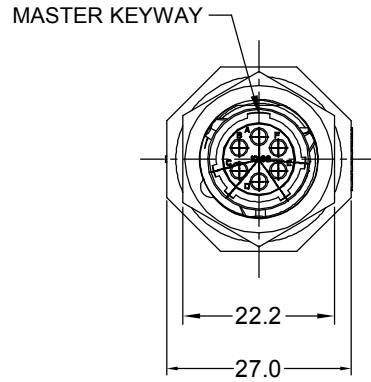

PANEL CUT OUT REFERENCE

KEY	PART NUMBER	
		-40°C ~ 105°C
N	RTS710N6S	RTS710N6S03

NOTES : (UNLESS OTHERWISE SPECIFIED)

- MATERIAL :
 - SHELL : THERMOPLASTIC , UL94 V-0.
 - INSERT : THERMOPLASTIC , UL94 V-0.
 - O-RING : NBR/SILICONE RUBBER.
 - SEAL GASKET : NBR/SILICONE RUBBER.
 - JAM NUT : ALUMINIUM ALLOY , BLACK ANODIZING.
- SPECIFICATIONS :
 - RATED CURRENT :
 - 2.1.1 STAMPED CONTACT 5A (MAX).
 - 2.1.2 MACHINED CONTACT 7.5A (MAX).
 - RATED VOLTAGE : 250V(AC/DC).
 - OPERATING TEMPERATURE : SEE TABLE.
 - DIELECTRIC WITHSTANDING VOLTAGE : LESS THAN 2 MILLIAMPS CURRENT LEAKAGE@1500 VOLTS AC.
 - INSULATION RESISTANCE : 5000 MEGOHMS MIN.
 - IP-CLASS : IP67 AND IP69K IN THE MATED CONDITION, PANEL EXTERNAL.
 - MATING CYCLES DURABILITY : 500 CYCLES MIN.
 - RoHS COMPLIANT.
- SUITABLE CONTACTS : 20# CONTACT.
- ALL DIMENSIONS ARE FOR REFERENCE USE ONLY.

QUANTITY	PART NUMBER	DESCRIPTION	ITEM
MATERIALS LIST			
UNLESS OTHERWISE SPECIFIED 1) All dimensions are in metric(mm). 2) Tolerances are as follows: 1 PL DEC ±0.30 Fractions ±1/64 2 PL DEC ±0.15 Angles ±1° 3 PL DEC ±0.08 3) Note reference =		SIGNATURES DATE DRAWN: Blink Jan-7-2021 CHECKED: Flan Jan-11-2021 ENGINEER: APPROVAL: Tommy Jan-13-2021 CUSTOMER:	
MATERIAL SPECIFICATIONS: THIS DRAWING IS SUPPLIED FOR INFORMATION ONLY. DESIGN FEATURES, SPECIFICATIONS AND PERFORMANCE DATA SHOWN HEREON ARE THE PROPERTY OF THE AMPHENOL CORPORATION. NO RIGHTS OF REPRODUCTION ARE IMPLIED. ALL DIMENSIONS ARE SUBJECT TO NORMAL MANUFACTURING VARIATIONS.		 Sine Systems - www.amphenol-sine.com 44724 Morley Drive Clinton Township, MI 48036	
PROCESS SPECIFICATIONS: NEXT ASSY:		ECO-MATE AQUARIUS, RECEPTACLE, JAM NUT, SIZE 10, 6POS, SOCKET.	
		SIZE TYPE DWG NO. B C- RTS710*6Sxx	REVISION A4
		SCALE SHEET OF NONE 1 1	

TITLE: ECO-MATE AQUARIUS RECEPTACLE, JAM NUT, SIZE 10, 6POS, SOCKET.
 DWG NO.: RTS710*6Sxx
 REV: A4
 SH: 1
 OF: 1