

REEL OF 900 SWITCHS SMT

R299.137.801

Series : **DIVERS**

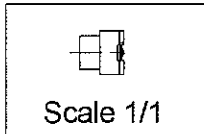
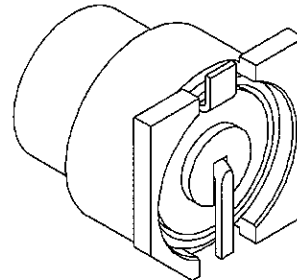
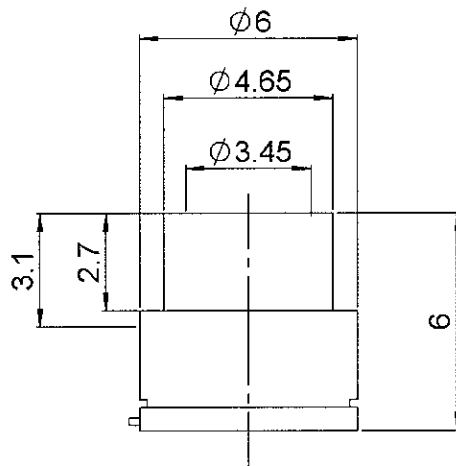
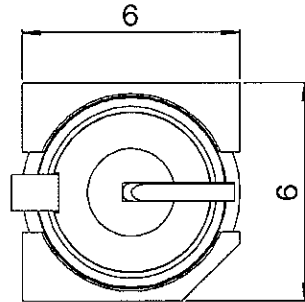

All dimensions are in mm.

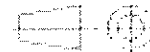

COMPONENTS	MATERIALS	PLATING (µm)
BODY	BRASS	GOLD 0.2 OVER NICKEL 2
CENTER CONTACT	BRASS	GOLD 0.5 OVER NICKEL 2
OUTER CONTACT	-	-
INSULATOR	POLYSULFURE DE PHENYLENE	-
GASKET	-	-
OTHERS PARTS	STAINLESS STEEL	-
-	-	-
-	-	-

Issue : 0722 F

In the effort to improve our products, we reserve the right to make changes judged to be necessary.



REEL OF 900 SWITCHS SMT

R299.137.801

Series : **DIVERS**

PACKAGING

Standard	Unit	Other
900	'W' option	Contact us

SPECIFICATION

ELECTRICAL CHARACTERISTICS

Impedance	50	Ω
Frequency	0-4*	GHz
VSWR	1.4 + 0,0000	x F(GHz) Maxi
Insertion loss	0.2	\sqrt{F} (GHz) dB Maxi
RF leakage	- (- F(GHz)) dB Maxi
Voltage rating	100	Veff Maxi
Dielectric withstanding voltage	350	Veff mini
Insulation resistance	5000	M Ω mini

ENVIRONMENTAL

Operating temperature	-40/+110	$^{\circ}$ C
Hermetic seal	NA	Atm.cm3/s
Panel leakage	NA	

OTHER CHARACTERISTICS

Assembly instruction

Others :

isol. between 2 ways:-25 dBmin at 2 GHz

*Usable 0 to 6GHz

MECHANICAL CHARACTERISTICS

Center contact retention		
Axial force – Mating end	NA	N mini
Axial force – Opposite end	NA	N mini
Torque	NA	N.cm mini
Recommended torque		
Mating	NA	N.cm
Panel nut	NA	N.cm
Mating life	80000	Cycles mini
Weight	0,5260	g

Issue : 0722 F

In the effort to improve our products, we reserve the right to make changes judged to be necessary.



REEL OF 900 SWITCHS SMT

R299.137.801

Series : **DIVERS**

SOLDER PROCEDURE

1. Deposition of solder paste 'Sn Ag4 Cu0.5' on mounting zone by screen printing application. We recommend a low residue flux.
We advise a thickness of 150 microns mini (0.006 inch mini). Verify that the edges of the zone are clean.
2. Placement of the receptacle on the mounting zone with an automatic machine of 'pick and place' type.
Video camera is recommended for the positioning of the component. Adhesive agents must not be used on the receptacle.
3. Soldering by infra-red reflow.
Below, please find the typical profile to use.
4. Cleaning of printed circuit boards.
5. Checking of solder joints and position of the component by visual inspection.

TEMPERATURE PROFILE

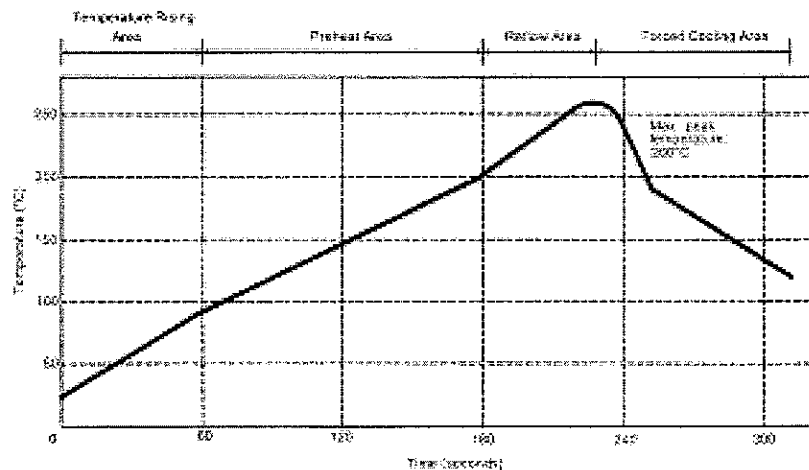

Parameter	Value	Unit
Temperature rising Area	1 - 4	°C/sec
Max Peak Temperature	260	°C
Max dwell time @260°C	10	sec
Min dwell time @235°C	20	sec
Max dwell time @235°C	60	sec
Temperature drop in cooling Area	-1 to -4	°C/sec
Max dwell time above 100°C	420	sec

Issue : 0722 F

In the effort to improve our products, we reserve the right to make changes judged to be necessary.



RADIALL®

REEL OF 900 SWITCHS SMT

R299.137.801

Series : **DIVERS**

STRAIGHT SWITCH CMS

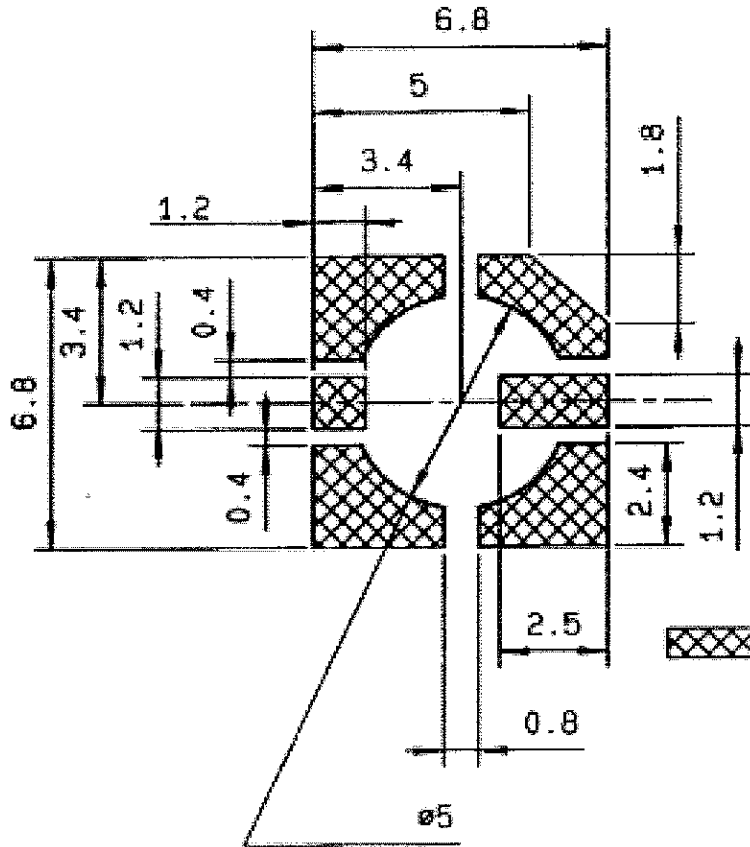

6.8 x 6.8 square
or 6.8 diameter.

 Turned copper (Land for solder paste)

Line : Coper thickness 18 microns.
PCB thickness : 0.063 (1.6).
General tolerance ± 0.0016

Matiere : FR4 simple face

**AIR SUNCTION
CAMERA**

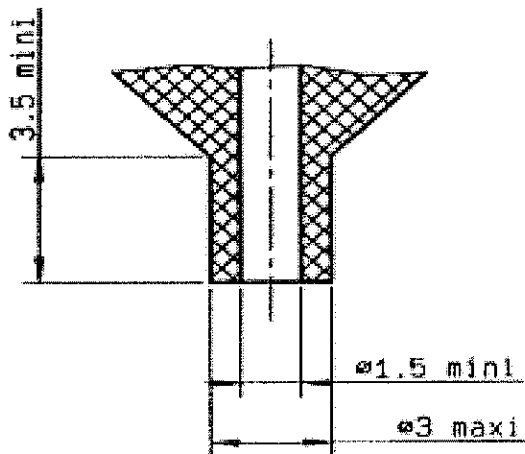

SHADOW FOR VIDEO

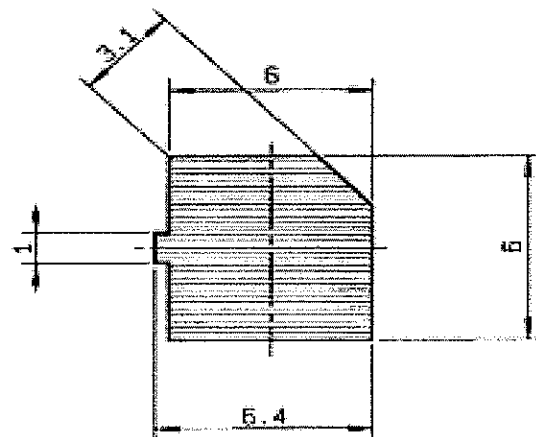

Issue : 0722 F

In the effort to improve our products, we reserve the right to make changes judged to be necessary.



RADIALL®

REEL OF 900 SWITCHS SMT

R299.137.801

Series : **DIVERS**

VSWR 1.3 max unmated
VSWR 1.4 max mated

STRAIGHT SWITCH CMS

VSWR
(Measured performance)

Switch connected with R299.138
Auxiliary antenna .Way 2
Switch alone (no connected)
Mobile phone antenna .Way 1

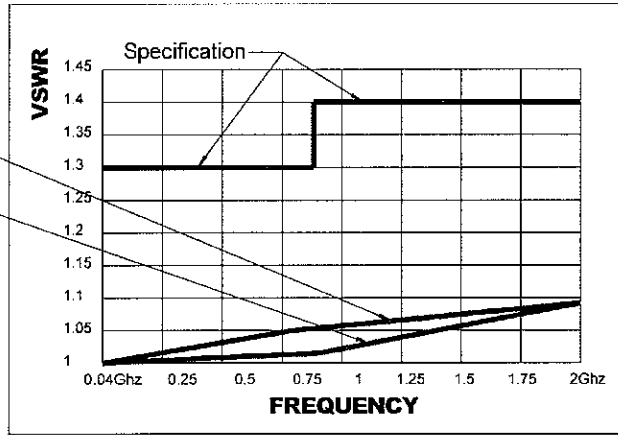
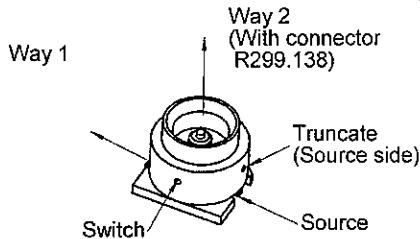

INSERTION LOSS
(Measured performance)

Switch connected with R299.138

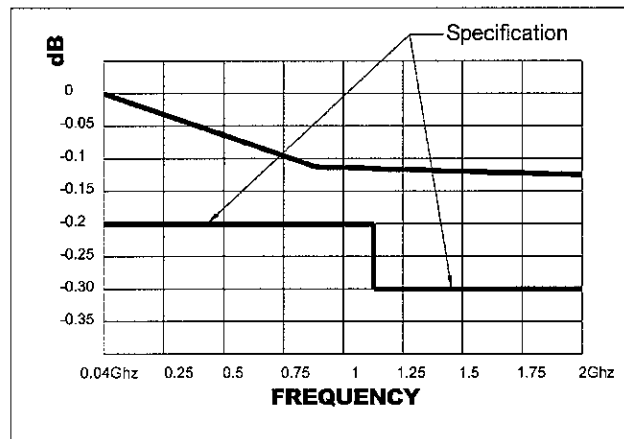
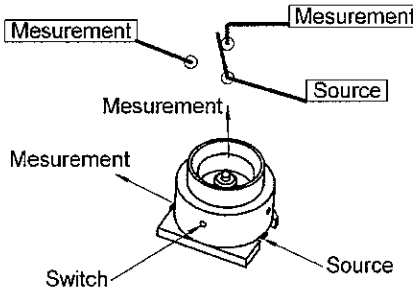

0-2 Ghz --> - .2dBmax. unmated
--> - .3dB max mated

ISOLATION
(Measured performance)

Switch connected with R299.138

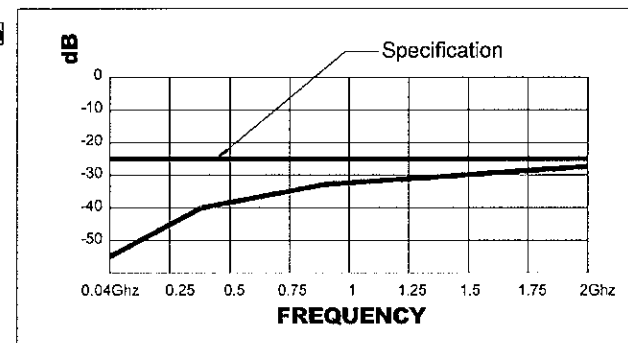
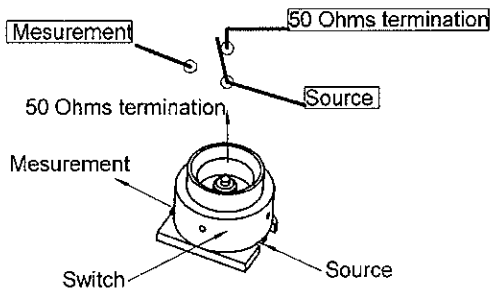

0-2 Ghz --> -25dB Max

STRAIGHT SWITCH CMS

Issue : 0722 F

In the effort to improve our products, we reserve the right to make changes judged to be necessary.



REEL OF 900 SWITCHS SMT

R299.137.801

Series : **DIVERS**

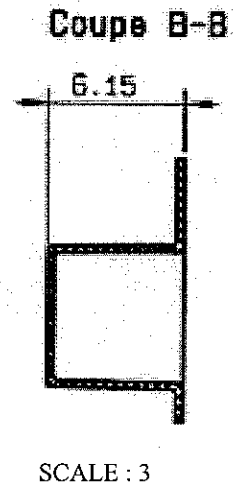
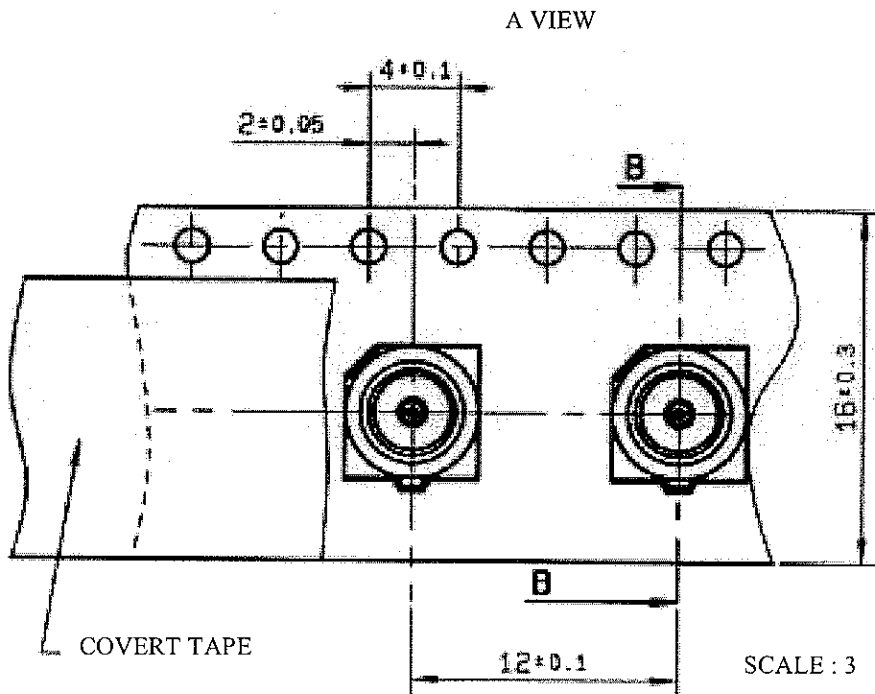
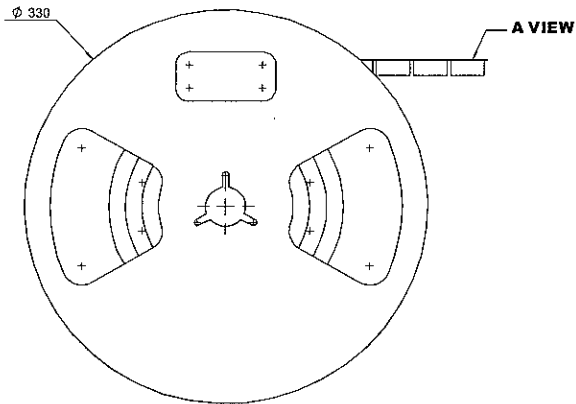

Issue : 0722 F

In the effort to improve our products, we reserve the right to make changes judged to be necessary.



RADIALL