3-20pos. AMP DUOPLUG 2.5™ Connector System

APPLICATION SPECIFICATION
3-20 pos. AMP DUOPLUG 2.5™ Connector System

1. SCOPE

The AMP DUOPLUG 2.5 Connectors * can be used as direct or indirect connectors for wire to board applications.

For the indirect application the pair of flat spring contacts the small side of the tab contacts.

The tab contacts are assembled in a housing and soldered to the PCB.

The direct application connects directly specified pads of the PCB edge which can be lamination coated on single or both sides.

The female connectors are available in two wire ranges (DGB I and DGB II) and are fully or selectively loaded.

1.1 Contents

This specification contains criteria which guarantee a quality level acc. to prod. spec. 108-18056, if the AMP DUOPLUG 2.5 Connector System female connector has been terminated in accordance with AMP-technology.

The instructions are valid for the use on any kind of AMP application tools.

1.2 Applicable Instructions

DIN 41 611 part 6

2. SYSTEM FEATURES

AMP DUOPLUG 2.5 Connector System
Female Connector

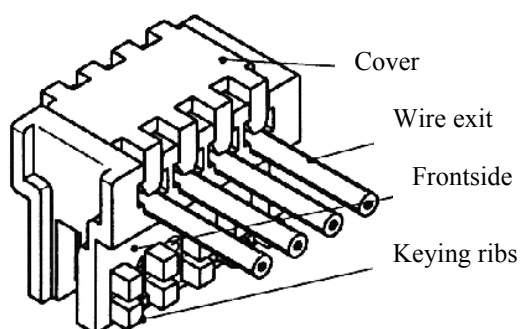

Fig. 1

AMP DUOPLUG 2.5 Connector System
Direct connection
Incl. frame for keying and positioning features

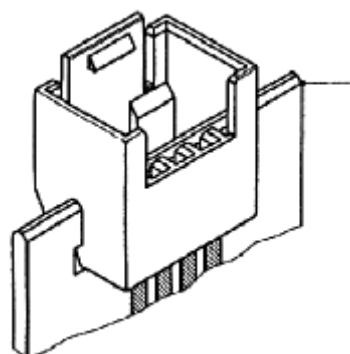

Fig. 2

AMP DUOPLUG 2.5 Connector System
Indirect connection
Male connector, closed-end version

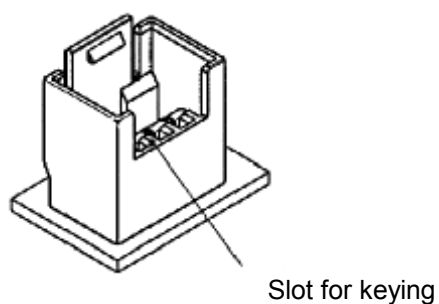

Fig. 3

AMP DUOPLUG 2.5 Connector System
Indirect connection
Male connector, feed-through version (optional)

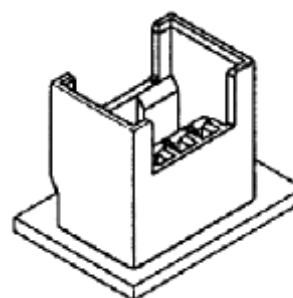

Fig. 4

3. 3. SPECIFIC REQUIREMENTS

Dimensions, function and appearance of the AMP DUOPLUG 2.5 connectors have to adhere to the following requirements:

3.1 Visible check of connectors before application

Visible inspection is sufficient, and in case of uncertainty, a dimensional check is necessary.

3.1.1 Coordination wire – contact

Prerequisite for a perfect wire connection of AMP DUOPLUG 2.5 connectors is:

- a) wire performance
acc. to par. 4.3
- b) contact performance
Wire section (par. 4.3.1) and contact to be applied have to be coordinated.
Wire range identification is marked on ID contact.
For visible inspection the contact has to be removed from the housing.

DGB I: Contact with coined number "0.22" suitable for wire acc. to par. 4.3.1 a

DGB II: Contact with coined number "0.35" suitable for wire acc. to par. 4.3.1 b

3.1.2 Contact

Contact may not show any damage which would endanger correct function.
Scratches which do not reach the basis material are allowed and do not endanger function.

3.1.3 Position of IDC slot

Position of IDC slot has to be acc. to respective symmetry tolerances.

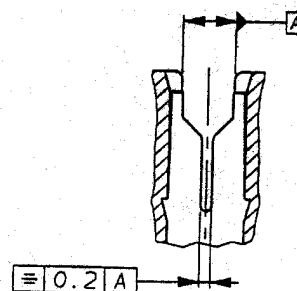

Fig. 5

3.1.4 Housing

Housings must be free of damage originating from machine or tool failures.

3.1.5 Wire

Wire may not show any damages.

3.2 Visible check of terminated connectors

For the following, a visible check is sufficient and only in the case of uncertainty a dimensional inspection is necessary.

3.2.1 Contact

The contact may not have any damages which could endanger correct function. Especially damages of the contact caused by insertion tool or incorrect handling have to be avoided. Slight scratches which do not touch the basic material are not relevant to the function and do not endanger function.

3.2.2 Control of wire depth

For a correct function of IDC, the wire depth is important. A check of the wire depth is only possible before fixing the cover.

Depending on the kind of insulation material of the wire, the funnel entry of the contact slot should be visible from the top. This should be adhered as proof of quality. Should this feature not be visible with the bare eye, (e.g. remaining parts of insulation), procedure 4.4 applies.

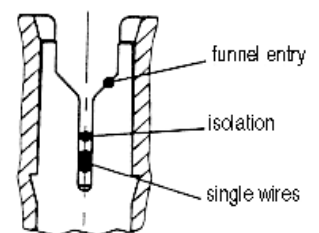

Fig. 6

3.2.3 Contact position in housing

After completion of working process, the contact has still to be in correct position in housing. (Fig. 7, see also point 4.6)

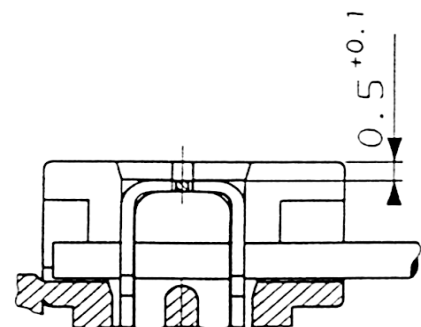

Fig. 7

3.2.4 Position of wire in the housing

The wire may only be inserted max. 0.5 mm recede from end of cavity.

It is not allowed that the wire overlaps the housing (Fig. 8, see also item 4.5).

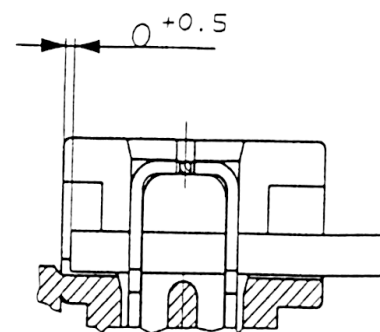

Fig. 8

3.2.5 Housing

The processed housing may not show any damages which refer to incorrect machine adjustment or tool breakage.

3.2.6 Cutting of the keying ribs

After cutting of the keying ribs the housings must be burr-free respectively acc. to tolerances shown in fig. 9. If, caused by the cutting process the housing breaks slightly, this has no effect on the function and is allowed. Don't cut all keying ribs. At least one keying rib has to remain (position is unimportant).

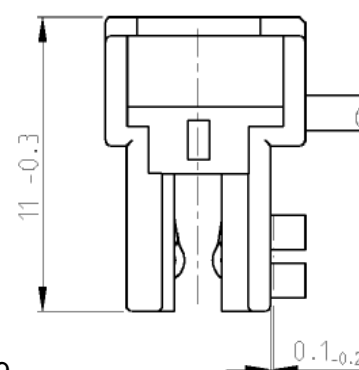

Fig. 9

3.2.7 Cutting of cover

Remaining parts of cover / housing caused by the cutting process has to be within tolerances shown in fig. 10. Slight breakage of housing is allowed and does not effect function.

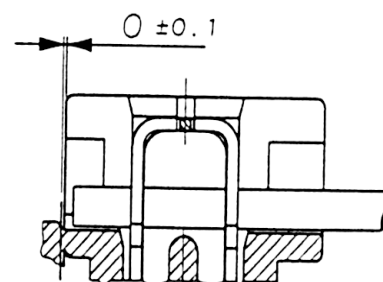

Fig. 10

3.2.8 Cover locking

After inserting the wire, contact and wire are protected by fixing the cover. The cover will function if all locking latches (front and back) are properly fixed (fig. 11). Slight deformation of locking latches is allowed and does not effect function. The overall height of the terminated connector can be seen from picture 9.

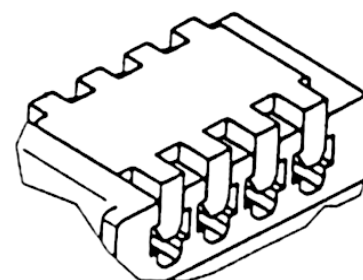

Fig. 11

4. Quality precautions

The actions listed below serve as quality assurance of the AMP DUOPLUG 2.5 Connector System as to the prod.-spec. 108-18056 and apply when changing the following parameters:

- a) Product introduction
- b) Change of wire
- c) Tooling change

QUALITY FEATURES

a) width of IDC slot	(4.1)	f) contact position	(4.6)
b) position of IDC slot	(4.2)	g) cutting of the keying ribs	(4.7)
c) wire quality	(4.3)	h) cutting of the cover	(4.8)
d) wire insertion depth	(4.4)	j) cover locking	(4.9)
e) position of wire	(4.5)		

4.1 Slot dimension / width of IDC slot

Tyco guarantees the slot dimension which is decisive to obtain an optimal connection.

4.2 Position of IDC slot

See item 3.1.3

Visible inspection is sufficient, and in the case of uncertainty, a dimensional check is necessary.

4.3 Wire quality

The wire specification (see sheet 9) must be kept. Should deviations of wire occur, an AMP approval is necessary.

4.3.1 Wire

AMP DUOPLUG 2.5 female parts are produced to fit the following wire ranges (DGB):

a.) DGB I	solid wire	$\varnothing 0.4 \text{ mm}$ and $\varnothing 0.5 \text{ mm}$
	bonded wire	$7 \times \varnothing 0.15 = 0.12 \text{ mm}^2$
	bonded wire	$7 \times \varnothing 0.16 = 0.14 \text{ mm}^2$
	stranded wire	$7 \times \varnothing 0.20 = 0.22 \text{ mm}^2$
	stranded wire	$12 \times \varnothing 0.21 \text{ mm} = 0.35 \text{ mm}^2$
b.) DGB II	stranded wire	$7 \times \varnothing 0.25 \text{ mm} = 0.35 \text{ mm}^2$
c.)	Ribbon cable in the same wire ranges as item a and b	

Remarks: The wire listed under item 4.3.1 and the wire specification (sheet 9) give only basic information. Upon request, a list of approved wires and its producers can be obtained.

4.3.2 Insulation

The AMP DUOPLUG 2.5 System female parts are designed to fit wires with an insulation diameter of $1.3 \text{ mm} \pm 0.1$.

The usable wire should have a semi-rigid * PVC insulation with a shore A hardness 92 ± 3 according to DIN 53 505, for example YJ3 per VDE 0209

Remarks: If deviations regarding description as per item 4.3.2 occur, please contact AMP, because AMP approval is necessary !

4.4 Wire insertion depth

The wire depth determinates the position of the single wires in the insulation displacement slot. It has to be guaranteed, that the conductor compound is deep enough in the slot area. This can be guaranteed when, with the wire conductor with an isolation diameter of 1.2 – 1.4 mm the wire is inserted according to picture 12 (see also par. 3.2.2)

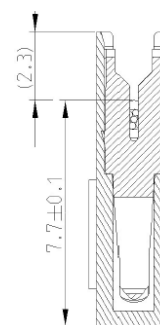

Fig. 12

4.5 Position of wire

The wire must be inserted into the housing at the end or max. 0.5 mm away from the end of the cavity (fig. 13). It is not allowed to insert the wire exceeding the end of the cavity.

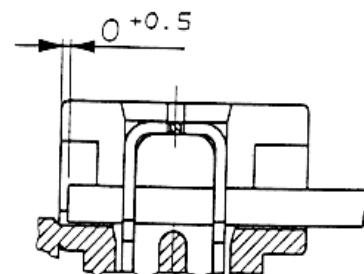

Fig. 13

4.6 Contact position

The symmetric tolerance between contact and housing has to be according to dimensions in fig. 14. Contact edges may not be visible in the mating area.

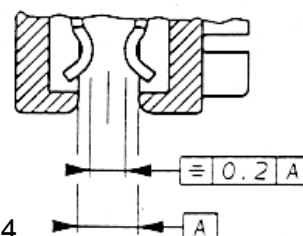

Fig. 14

4.7 Cutting of keying ribs

Cutting of keying ribs must be acc. to item 3.2.6

4.8 Cover cutting area

The cutting area of the cover must be according to item 3.2.7

4.9 Cover locking

The locking of the cover must be acc. to item 3.2.8

5. QUALITY APPROVAL

5.1 Tensile strength of the applied wire

The tensile strength of the connected wire must have the result as shown in the following table (fig. 15).

Wire version	Horizontal direction fig. 15
Solid wire \varnothing 0.5 mm	30 N
Stranded wire 7x \varnothing 0.2 mm = 0.22 mm ² AWG 24	30 N
Stranded wire 7x \varnothing 0.2 mm = 0.35 mm ² AWG 22	30 N

Fig. 15

5.2 Cross section pictures

The embedding of the grinding parts should be done in vacuum in order to assure exact filling of hollow spaces. The grinding direction has to be parallel to contact slot (fig. 18) so that movements within the surrounding insulation are more or less impossible. In order to meet the actual contact zone within the contact material thickness during grinding, it is necessary to look and grind alternately.

The analysis of the cross section pictures has to be done with Tyco in case of doubt. The basic rule for stranded wire is: With 7-stranded wires, 4 single wires have to be seen in contact with the contact slot and in contact with themselves.

With 12-stranded wires, a minimum of 9 wires have to be in the parallel slot area and have to be in a rigid compound.

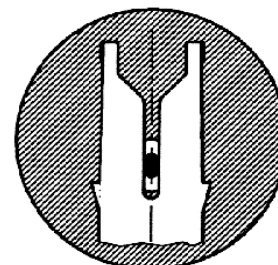
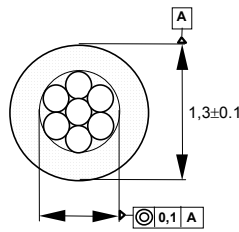
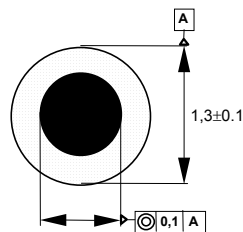

Fig. 16

Wire Specification DGB I



Stranded wire: AWG
7 x Ø 0.2 = 0.22 mm²



Solid wire: Ø 0.4 – 0.5 mm

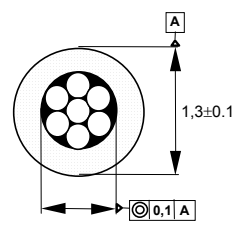

Bonded wire:
7 x Ø 0.15 mm = 0.12 mm²
7 x Ø 0.16 mm = 0.14 mm²

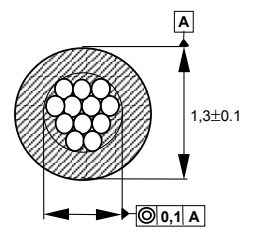

Stranded wire: AWG 22
12 x Ø 0.20 mm = 0.35 mm²

Wire Specification DGB II

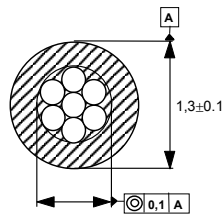

Litze: AWG 22
7 x Ø 0.25 mm = 0.35 mm²

Wire Specification Ribbon Cable

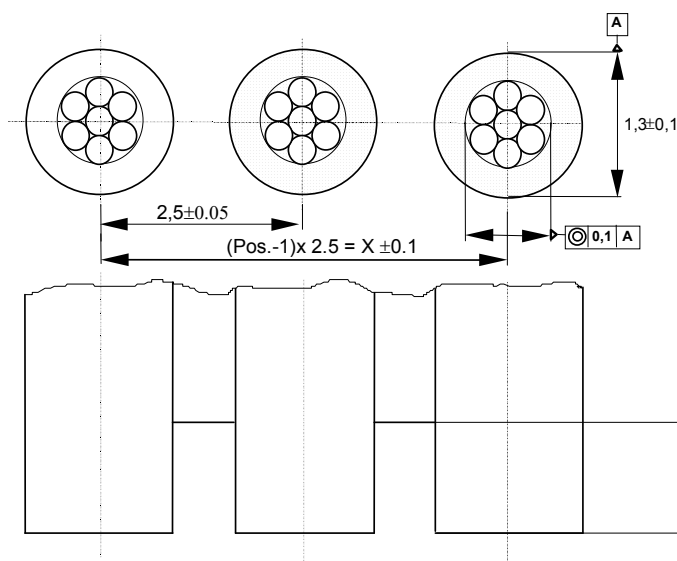

Same wire ranges
as the single wires.