

PK シリーズ  
SERIES

85°C 標準品  
85°C Standard

・85°C 2000時間品。  
Load Life : 85°C 2000 hours.

RoHS  
compliance

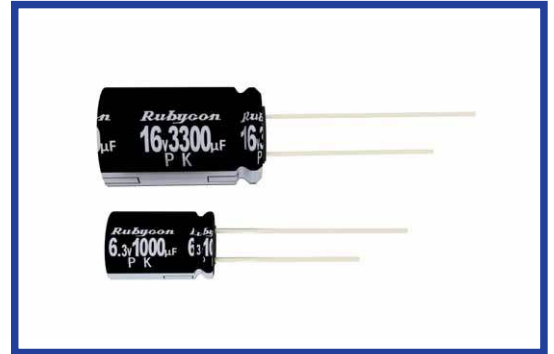

◆規格表 / SPECIFICATIONS

項目 Items	特性 Characteristics																																																											
カテゴリ温度範囲 Category Temperature Range	-40~+85°C	-25~+85°C																																																										
定格電圧範囲 Rated Voltage Range	6.3~400Vdc	450Vdc																																																										
静電容量許容差 Capacitance Tolerance	±20%(20°C, 120Hz)																																																											
漏れ電流 Leakage Current(MAX)	6.3~100Vdc	160~450Vdc																																																										
	I=0.01CV又は3µAのいずれか大なる値以下 I=0.01CV or 3µA whichever is greater. (定格電圧印加2分後) (After 2 minutes application of rated voltage)	CV≤1000	CV>1000																																																									
		I=0.1CV+40µA以下(1分値) I=0.1CV+40µA (1minute) I=0.03CV+15µA以下(5分値) I=0.03CV+15µA (5minutes)	I=0.04CV+100µA以下(1分値) I=0.04CV+100µA (1minute) I=0.02CV+25µA以下(5分値) I=0.02CV+25µA (5minutes)																																																									
I=漏れ電流(µA) Leakage Current	C=静電容量(µF) Capacitance	V=定格電圧(Vdc) Rated Voltage																																																										
損失角の正接 (tanδ) Dissipation Factor(MAX)	<table border="1"> <tr> <td>定格電圧(Vdc) Rated Voltage</td> <td>6.3</td><td>10</td><td>16</td><td>25</td><td>35</td><td>50</td><td>63</td><td>100</td><td>160</td><td>200</td><td>250</td><td>350</td><td>400</td><td>450</td> <td>(20°C, 120Hz)</td> </tr> <tr> <td>tanδ</td> <td>0.28</td><td>0.24</td><td>0.20</td><td>0.16</td><td>0.14</td><td>0.12</td><td>0.10</td><td>0.10</td><td>0.20</td><td>0.20</td><td>0.20</td><td>0.25</td><td>0.25</td><td>0.25</td> <td></td> </tr> </table>												定格電圧(Vdc) Rated Voltage	6.3	10	16	25	35	50	63	100	160	200	250	350	400	450	(20°C, 120Hz)	tanδ	0.28	0.24	0.20	0.16	0.14	0.12	0.10	0.10	0.20	0.20	0.20	0.25	0.25	0.25																	
	定格電圧(Vdc) Rated Voltage	6.3	10	16	25	35	50	63	100	160	200	250	350	400	450	(20°C, 120Hz)																																												
tanδ	0.28	0.24	0.20	0.16	0.14	0.12	0.10	0.10	0.20	0.20	0.20	0.25	0.25	0.25																																														
1000µFを越えるものは1000µF増す毎に上表の値に0.02を加えた値とする。 When capacitance is over 1000µF, tanδ shall be added 0.02 to the listed value with increase of every 1000µF.																																																												
耐久 Endurance	85°C中で2000時間定格電圧(リップル重畳)印加後、下記項目を満足すること。 After applying rated voltage with rated ripple current for 2000 hours at 85°C, the capacitors shall meet the following requirements.																																																											
	静電容量変化率 Capacitance Change	初期値の±25%以内 Within ±25% of the initial value.																																																										
	損失角の正接 Dissipation Factor	規格値の200%以下 Not more than 200% of the specified value.																																																										
漏れ電流 Leakage Current	規格値以下 Not more than the specified value.																																																											
低温特性 Low Temperature Stability (インピーダンス比) Impedance Ratio(MAX)	<table border="1"> <tr> <td>定格電圧(Vdc) Rated Voltage</td> <td>6.3</td><td>10</td><td>16</td><td>25</td><td>35</td><td>50</td><td>63</td><td>100</td><td>160</td><td>200</td><td>250</td><td>350</td><td>400</td><td>450</td> <td>(120Hz)</td> </tr> <tr> <td>Z(-25°C)/Z(20°C)</td> <td>5</td><td>4</td><td>3</td><td>2</td><td>2</td><td>2</td><td>2</td><td>2</td><td>3</td><td>3</td><td>4</td><td>5</td><td>5</td><td>7</td> <td></td> </tr> <tr> <td>Z(-40°C)/Z(20°C)</td> <td>12</td><td>10</td><td>8</td><td>5</td><td>4</td><td>3</td><td>3</td><td>3</td><td>4</td><td>4</td><td>8</td><td>8</td><td>10</td><td>-</td> <td></td> </tr> </table>												定格電圧(Vdc) Rated Voltage	6.3	10	16	25	35	50	63	100	160	200	250	350	400	450	(120Hz)	Z(-25°C)/Z(20°C)	5	4	3	2	2	2	2	2	3	3	4	5	5	7		Z(-40°C)/Z(20°C)	12	10	8	5	4	3	3	3	4	4	8	8	10	-	
	定格電圧(Vdc) Rated Voltage	6.3	10	16	25	35	50	63	100	160	200	250	350	400	450	(120Hz)																																												
	Z(-25°C)/Z(20°C)	5	4	3	2	2	2	2	2	3	3	4	5	5	7																																													
Z(-40°C)/Z(20°C)	12	10	8	5	4	3	3	3	4	4	8	8	10	-																																														

◆リップル電流補正係数 / MULTIPLIER FOR RIPPLE CURRENT

周波数(Hz) Frequency	60(50)	120	500	1k	10k≤
0.47~1µF	0.50	1.00	1.20	1.30	1.50
2.2~4.7µF	0.65	1.00	1.20	1.30	1.50
10~47µF	0.80	1.00	1.20	1.30	1.50
100~1000µF	0.80	1.00	1.10	1.15	1.20
2200~33000µF	0.80	1.00	1.05	1.10	1.15

◆副記号 / OPTION

	記号 Code
PETスリーブ PET Sleeve	EFC

◆寸法図 / DIMENSIONS (mm)

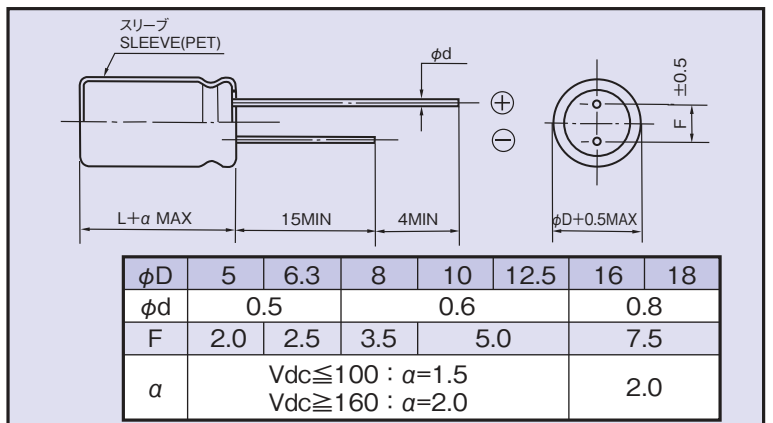

◆呼称方法 / PART NUMBER

□□□	PK	□□□□□	M	□□□	□□	D×L
定格電圧 Rated Voltage	シリーズ名 Series	静電容量 Capacitance	静電容量許容差 Capacitance Tolerance	副記号 Option	リード加工記号 Lead Forming	ケースサイズ Case Size

