

5	Gasket:Stainless steel surface plating Ni.	1
4	Nut:iron surface plating Ni.	1
3	Black high temperature plastics UL94 V-0	
2	Pin:brass 0.25um Au over Ni	
1	Housing:brass 0.25um Au over Ni	
No.	Specification	Qty

所有权信息:
 本文件所有权属于 GLOBTEK 公司, 任何整体和部分的复制都是禁止和非法的, 除非取得 GLOBTEK 公司的授权允许。
 PROPRIETARY INFORMATION:
 PROPRIETARY OF GLOBTEK, INC. ANY REPRODUCTION, DISCLOSURE OR USE OF THIS DRAWING IN WHOLE OR PART, IS HEREBY PROHIBITED EXCEPT AS SPECIFIED IN WRITING BY GLOBTEK, INC.

REVISION			
REV	DESCRIPTION	DATE	APPROVED
A	Initial Release	2018.08.16	JET
B	Update specifications, RFS.27559	07/28/20	MK

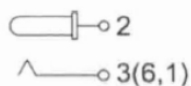
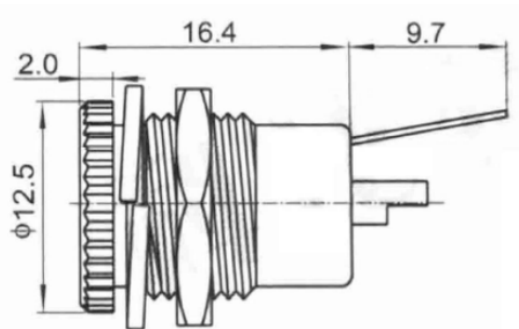
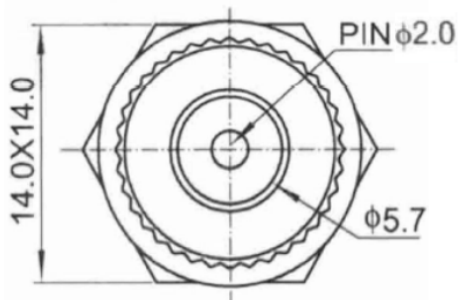

SPECIFICATIONS

parameter	conditions/description	min	typ	max	units
rated input voltage			50		Vdc
rated input current				8	A
contact resistance				30	mΩ
insulation resistance		100			MΩ
voltage withstand	at 50/60Hz for 1 minute	1500			Vac
insertion/withdrawal force		0.3		3	kg
Relative humidity				98%	(40°C)
life		10000			cycles

尾注:
 Globtek 公司不对未经批准而擅自修改部件而影响的性能和负责, 终端用户必须参考 UL、CSA 或 EN 标准规定正确的安装。

禁用:
 Globtek 产品未授权不得用于医疗设备中以及危险环境核试验或者飞机上, 除非有 GLOBTEK 公司首席执行官的书面正式批准。

Foot Note:
 Globtek Inc. will not be liable for the safety and performance of these parts if unauthorized access and repair occurs. End user should consult applicable UL, CSA or EN standards for proper installation instructions

文件内容未经允许不得更改
 Contents of this document are subject to change without prior notice

RANGE	Tolerance table		
	GRADE 1	GRADE 2	GRADE 3
X.X	+/-0.05	+/-0.1	+/-0.2mm
X.XX	+/-0.08	+/-0.15	+/-0.1mm
x.xxx	+/-0.12	+/-0.25	+/-0.15mm
/	/	/	/

PART NO 零件号:	/	
MODEL NO 型号:	/	
Drawn and Checked By:	Bruce	Tolerances:
Double Checked By:		Grade 3
Approved By:	Jet	

GlobTek(Suzhou), Co.,Ltd
 Tel: +86-512-6279-0301 Fax: +86-512-6279-0355 Web: www.globtek.cn

DRAWING FOR WIRE P/N:
JACK-C-PANEL-8A (R)

A₁ Rev. B SHEET 1 OF 1

