

## SPECIFICATION

- Part No. : **CAB.0121**
- Product Name : Taoglas Cable Assembly  
SMA(F) Bulkhead Jack Straight to  
FME(F) Straight  
with 100mm RG-174 cable
- Photo :

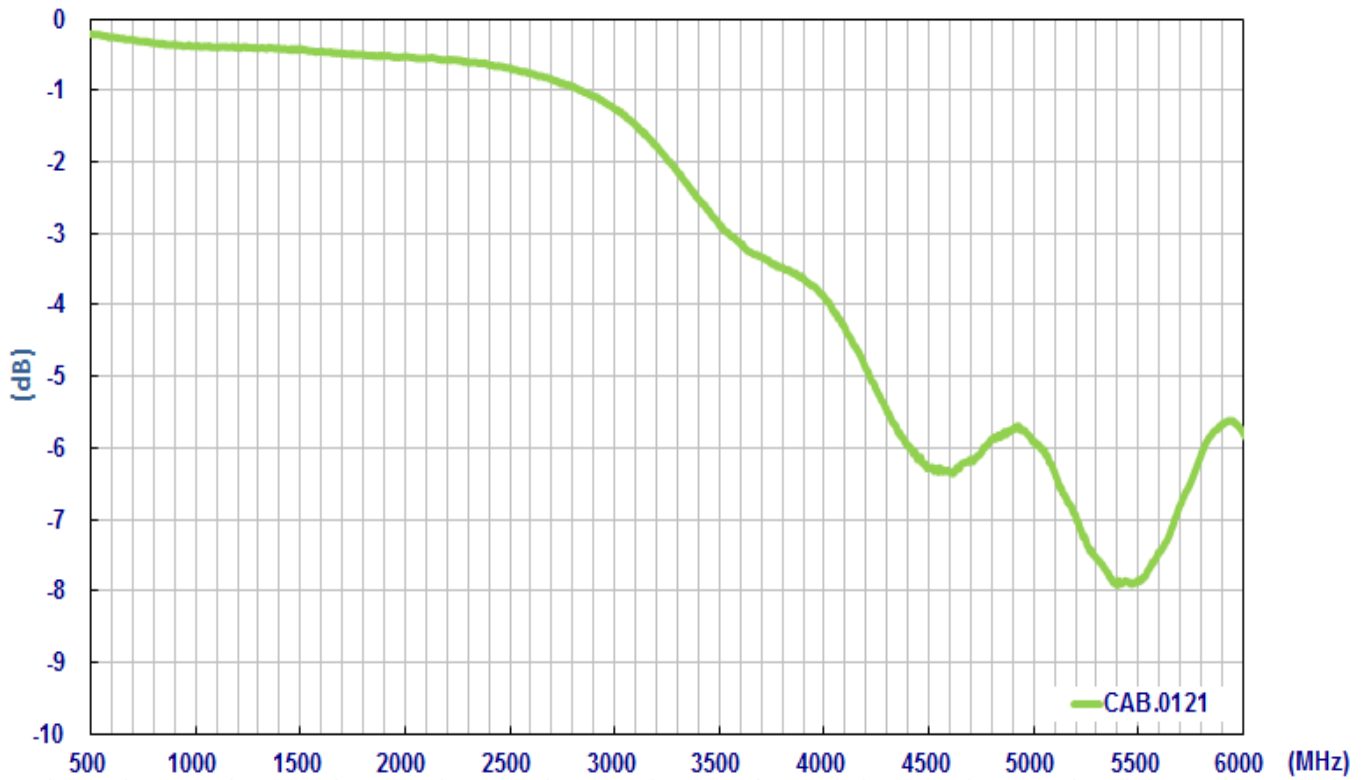

# 1. Cable Insertion Loss



# 2. RG-174 Cable Specification

## 2.1 Drawing – Cross Section

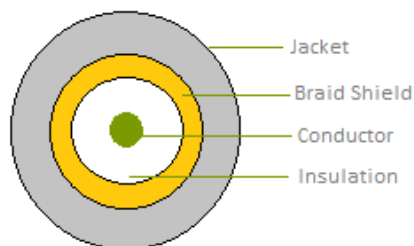

## 2.2 Structure and Dimensions



## 2.3 Electrical & Physical Specification

1	Temperature rating:	80°C
2	Voltage Rating:	30V
3	Insulation Resistance:	10MΩ-Km (Min) at 20°C dc 500V(EIA-364-21)
4	Conductor Resistance:	20°C 26 AWG: 148.96 Ω/Km (Max)
5	Capacitance:	30.8pf/ft
6	Dielectric Strength	AC 500V/1 minute no breakdown (EIA-364-20)
7	Impedance:	10MHz~3GHz 50 ± 5 Ω
8	Standard Attenuation:	100MHz 8.4 dB/100ft
		200MHz 12.5 dB/100ft
		400MHz 19.0 dB/100ft
		900MHz 31.0 dB/100ft
		1GHz 34.0 dB/100ft
		1.8GHz 49.4 dB/100ft
		2.34GHz 53.0 dB/100ft

### 3. Technical Drawing

#### 3.1 CAB.0121

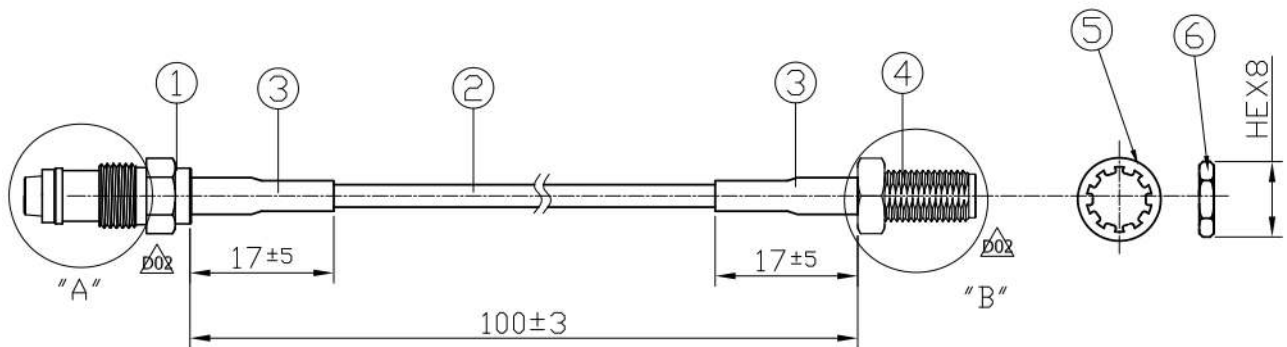

	Name	Material	Finish	QTY
①	FME(F) ST	Brass	Ni Plated	1
②	RG174 Coaxial Cable	PVC	Black	1
③	Heat Shrink Tube	PE	Black	2
④	SMA(F) BK ST	Brass	Gold	1
⑤	Washer	Brass	Gold	1
⑥	Nut	Brass	Gold	1

### 3.2 Connectors

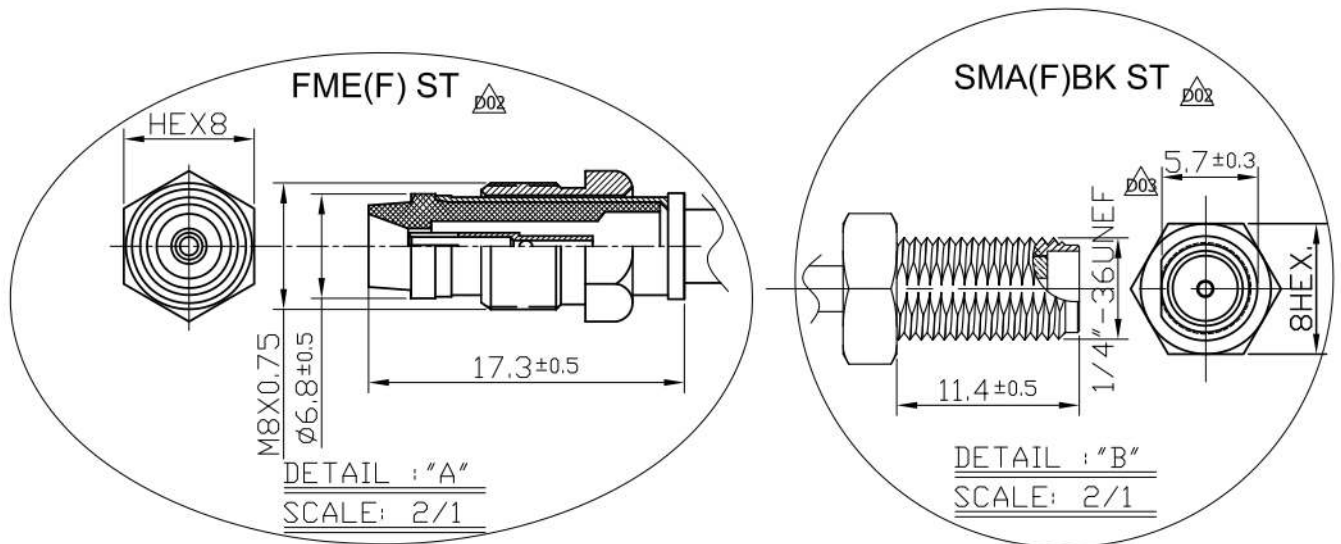

### 3.3 Recommended Mounting Hole – SMA(F) Bulkhead

