

| REVISIONS | | | |
|-----------|---|-----------|----------|
| REV | DESCRIPTION, ECN, EAR NO. | DATE | APP'D |
| A | PROPOSAL | MAY 07/18 | L.CHAN |
| B | ADD CONTACT WIDTH AND THICKNESS DIMENSION & PACKAGE DRAWING | DCE 07/20 | L.CHAN |
| C | UPDATING PACKAGE QUANTITY | JAN 28/21 | KELVIN.T |

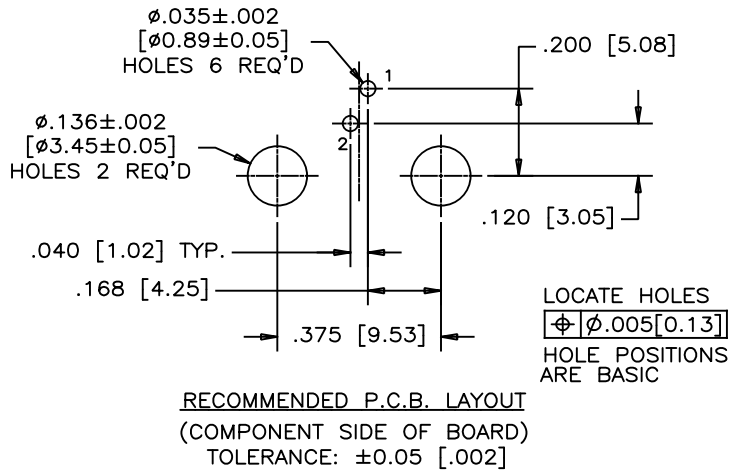
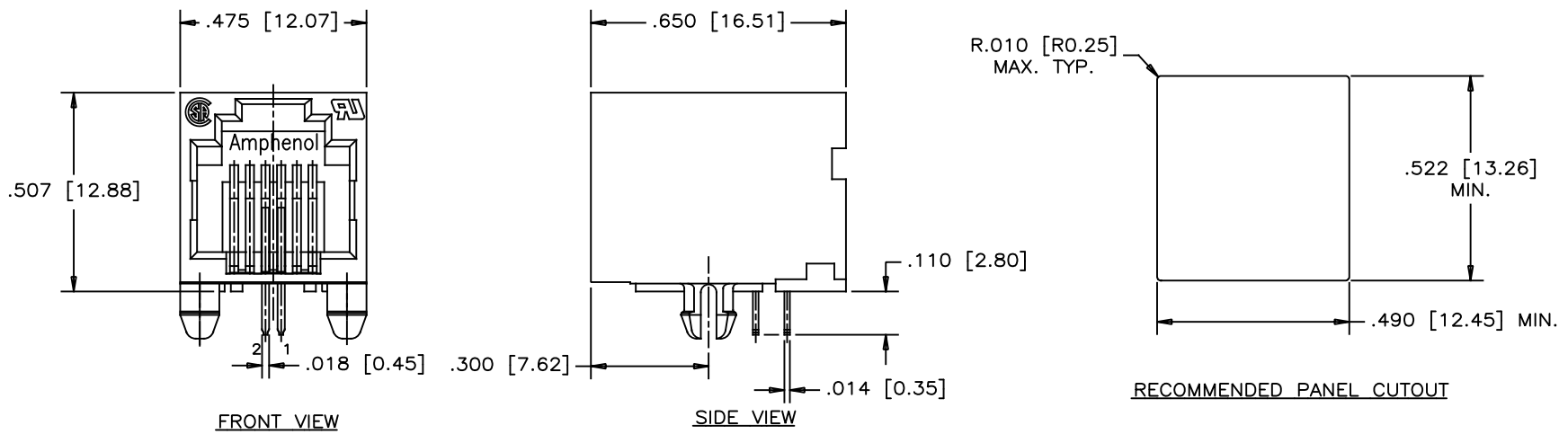

MATERIALS:

PLASTIC HOUSING: HIGH TEMPERATURE RESISTANT NYLON
UL FLAMMABILITY 94V-0. COLOUR: BLACK.
SOLDER REFLOW PROCESS COMPATIBLE

CONTACT: PHOSPHOR BRONZE

CONTACT PLATING: SELECTIVE GOLD PLATING ON MATING SURFACES
SEE AMPHENOL PART NUMBER FOR DETAIL.
100 MICRONS [2.54 MICRONS] MINIMUM TIN ALLOY
ON CONTACT TAILS.

AMPHENOL PART NUMBER: P-RJE01-X20-01

- GOLD PLATING
- 1 = 6 μ"
 - 6 = 50 μ"
 - G = 15 μ"
 - J = 30 μ"



| | | |
|----------------------------|------------------------|----------------------|
| UNLESS SPECIFIED OTHERWISE | DRAWN <i>HANSON.C</i> | <i>MAY 07/18</i> |
| PRIMARY UNITS INCHES | CHECKED <i>L.CHAN</i> | <i>MAY 07/18</i> |
| SECONDARY MILLIMETERS | M.E. APP'D | |
| REFERENCE IN PARENTHESES | Q.A. APP'D | |
| GENERAL TOLERANCES | DWG APP'D | |
| 1 DECIMAL PLACE ±0.38 | ENG. REL. NO. XX | |
| 2 DECIMAL PLACES ±0.25 | REF. | |
| 3 DECIMAL PLACES ±0.20 | THIRD ANGLE PROJECTION | DO NOT SCALE DRAWING |
| ANGULAR DEGREES ±1.5° | | |

| | |
|---|-----------------------------------|
| Amphenol Canada Corp. Commercial Products | |
| HIGH SPEED MODULAR JACK SINGLE PORT, 6 POSITIONS, 2 CONTACTS, WITHOUT SHIELD - RoHS COMPLIANT | |
| DWG NO. P-RJE01-X20-01 | REV C |
| CODE ID NO. 03554 | DWG SIZE X SCALE N/A SHEET 1 OF 2 |

| REVISIONS | | | |
|-----------|---|-----------|----------|
| REV | DESCRIPTION, ECN, EAR NO. | DATE | APP'D |
| A | PROPOSAL | MAY 07/18 | L.CHAN |
| B | ADD CONTACT WIDTH AND THICKNESS DIMENSION&PACKAGE DRAWING | DCE 07/20 | L.CHAN |
| C | UPDATING PACKAGE QUANTITY | JAN 28/21 | KELVIN.T |

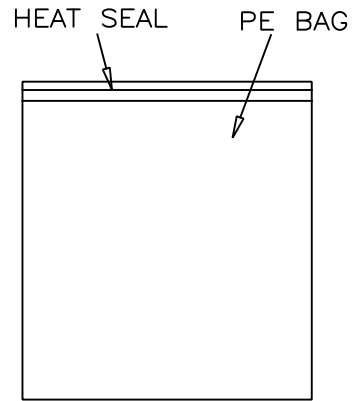
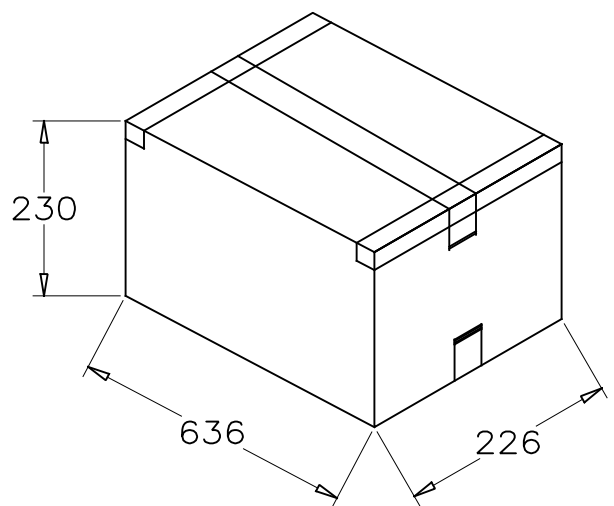
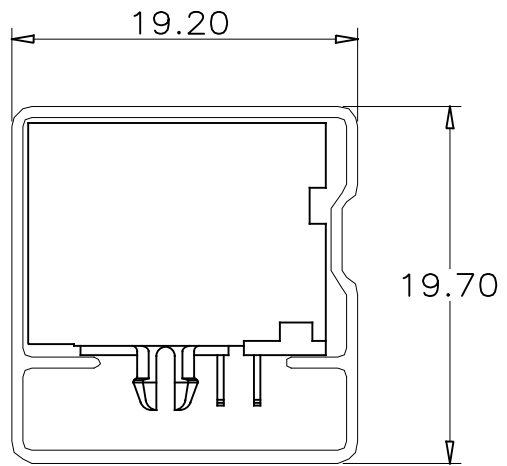
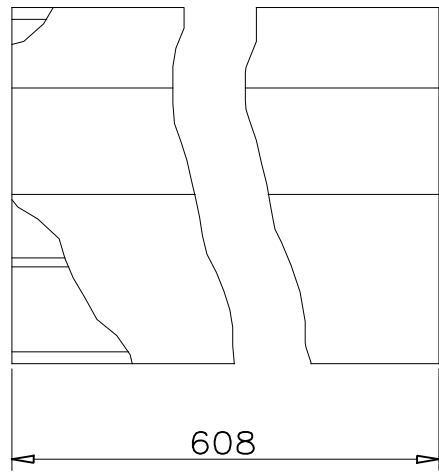

PACKAGING NOTES:
 1. ONE TUBE SHOULD HOLD 48 CONNECTORS.
 2. A FULLY LOADED CARTON SHOULD CONTAIN 100 TUBE (4800 PCS) OF CONNECTOR.
 3. PRODUCTS TO BE PACKAGED WITH COVER TAPE BY HEAT SEALING METHOD

| | | | | | |
|----------------------------|-----------------------|------------------------|----------------------|---|--------------|
| UNLESS SPECIFIED OTHERWISE | | DRAWN <u>HANSON.C</u> | <u>MAY 07/18</u> | Amphenol Canada Corp. Commercial Products | |
| PRIMARY UNITS INCHES | CHECKED <u>L.CHAN</u> | <u>MAY 07/18</u> | | | |
| SECONDARY MILLIMETERS | M.E. APP'D | | | HIGH SPEED MODULAR JACK SINGLE PORT, 6 POSITIONS, 2 CONTACTS, WITHOUT SHIELD - RoHS COMPLIANT | |
| REFERENCE IN PARENTHESES | Q.A. APP'D | | | | |
| GENERAL TOLERANCES | | DWG APP'D | | DWG NO. | |
| 1 DECIMAL PLACE | ±0.38 | ENG. REL. NO. XX | | P-RJE01-X20-01 | |
| 2 DECIMAL PLACES | ±0.25 | REF. | | | |
| 3 DECIMAL PLACES | ±0.20 | | | REV | |
| ANGULAR DEGREES | ±1.5° | THIRD ANGLE PROJECTION | DO NOT SCALE DRAWING | C | |
| | | CODE ID NO. 03554 | DWG SIZE X | SCALE N/A | SHEET 2 OF 2 |