

ITEM NO.	NAME	MATERIAL	NOTES
1	COVER	PA66	UL94-V0, RED
2	PIN	COPPER ALLOY	TIN PLATED

REV		ZONE	DESCRIPTION	DATE	ECN	BY
A		-	INITIAL RELEASE	09/24/2012	BU-J12374	TJN

PART NUMBER	NUMBER OF POLES	MARK	"A" DIM	"B" DIM
DSS2-5N-02P	2	DSS2.5N-02P	5	8.9
DSS2-5N-03P	3	DSS2.5N-03P	10	13.9
DSS2-5N-04P	4	DSS2.5N-04P	15	18.9
DSS2-5N-10P	10	DSS2.5N-10P	45	48.9

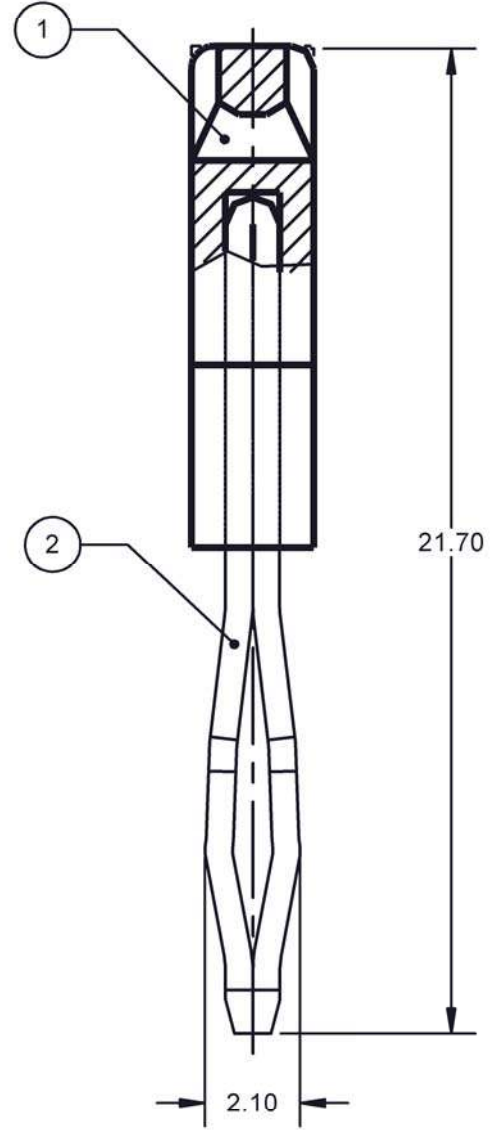

SEE TABLE FOR MARK

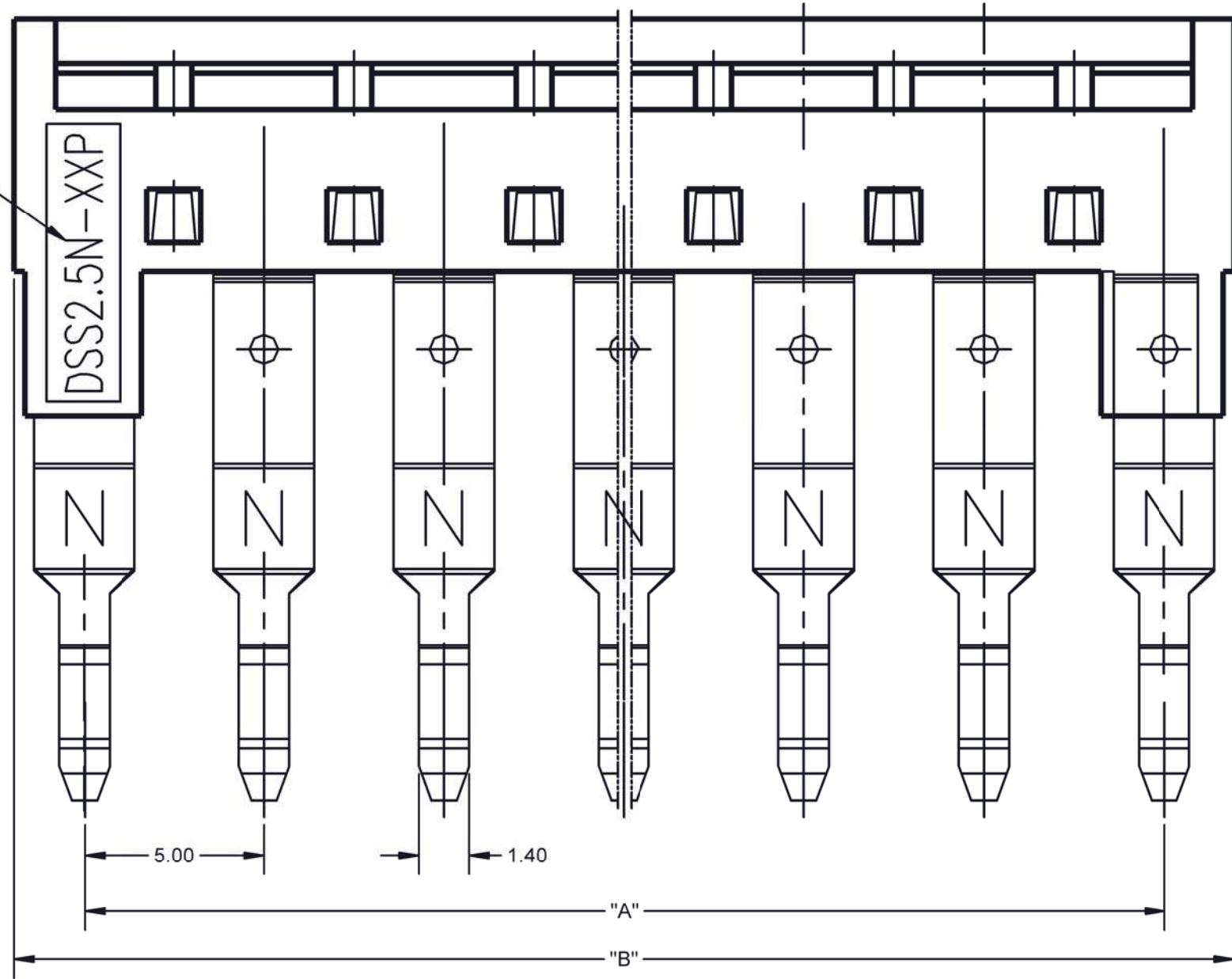

- NOTES:
- RATINGS: UL 600V/20A, IEC 1000V/24A
PITCH: 5.0MM
INSULATION WITHSTAND VOLTAGE 2000VAC/1MINUTE
TEMPERATURE RANGE -40°C~105°C
 - ASSEMBLY MUST BE FREE OF OIL, GREASE AND OTHER FOREIGN MATERIALS.
 - ASSEMBLY MUST COMPLY WITH RoHS SPECIFICATION #1P2163.

MODEL SOURCE DATA	MODEL VERSION	GENERAL DRAWING PRACTICES IN ACCORDANCE WITH ASME - Y14.100-2004 DIMENSIONS AND TOLERANCES IN ACCORDANCE WITH ASME - Y14.5M-1994	APPROVALS	DATE	 St. Louis, MO 63178 (USA)	
THIS DRAWING IS AN UNCONTROLLED COPY IF PRINTED OR SENT ELECTRONICALLY. DO NOT SCALE DRAWING.			ENGINEER: TJN DRAWN: TJN MANUFACTURING ENGINEER: --	09/26/2012 09/26/2012 --/--/----		TITLE: SCREW ON BRIDGE
CONFIDENTIAL. THE INFORMATION CONTAINED IN THIS DOCUMENT IS THE PROPERTY OF COOPER INDUSTRIES, INC. IT IS NOT FOR PUBLIC DISCLOSURE. POSSESSION OF THE INFORMATION DOES NOT CONVEY ANY RIGHT TO LOAN, SELL, OR DISCLOSE THE INFORMATION. UNAUTHORIZED REPRODUCTION OR USE OF THE INFORMATION IS PROHIBITED. THIS DOCUMENT IS TO BE RETURNED TO COOPER INDUSTRIES, INC. UPON COMPLETION OF THE PURPOSE FOR WHICH IT WAS LOANED OR UPON REQUEST.			UNLESS OTHERWISE SPECIFIED DIMENSIONS ARE IN MILLIMETERS TOLERANCES TO BE: ONE PLACE X.X = ±0.3 mm TWO PLACE X.X X = ±0.13 mm ALL ANGLES XX = ±1°		MATERIAL: SEE TABLE FINISH: SEE TABLE	SIZE: A3 DWG NO: DSS2-5N-XXP SCALE: 6:1
COPYRIGHT © COOPER INDUSTRIES, INC. THIS IS AN UNPUBLISHED WORK. THE DISCLOSURE OF THIS WORK IS LIMITED TO SELECT PERSONNEL. FURTHER DISSEMINATION OR DISCLOSURE TO THE PUBLIC IS PROHIBITED. THIS UNPUBLISHED WORK IS PROTECTED BY FEDERAL COPYRIGHT LAW AND ALL RIGHTS THEREUNDER ARE RESERVED BY COOPER INDUSTRIES, INC.			SPECIAL CHARACTERISTIC $\diamond (0)$ SIGNIFICANT CHARACTERISTIC $\triangle (0)$		SHEET 1 OF 1	
THIRD ANGLE PROJECTION					REV: A	