

FHSWLPWH

Test Button Remote Mounting Wall Plate

This wall plate can be used when remote mounting any Fulham test switch.

Image



Wall plate and screw color:
white with black lettering

Mechanical Drawings

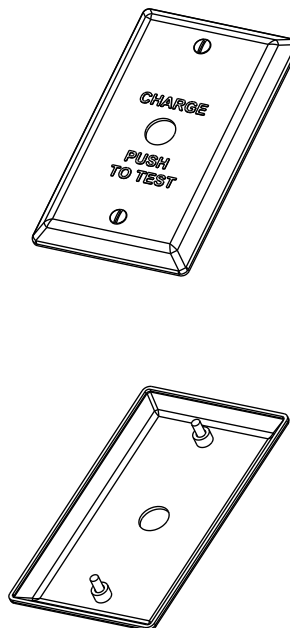
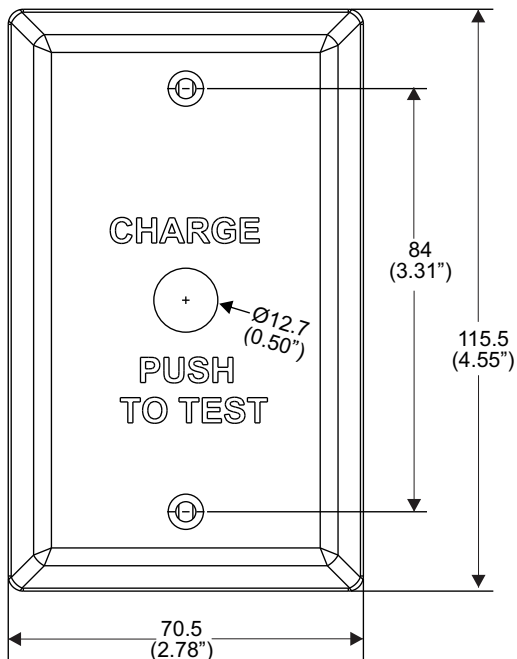

Includes:

1. "Charge push to Test" plate
2. (2) 6-32 x 1/2" LG mounting screws

Max. Remote Mounting Distance	
FHS2-UNV-36L	20'
FHS2-UNV-56S	20'
FHSAC1-UNV-40C	20'
FHSAC1-UNV-40L	20'
FHSAC1-UNV-40BLS	20'
FHSAC1-230-45CE	20'
FHSAC1-230-45CED	20'
FHSCP-UNV-10P-L-SD	20'
FHSCP-UNV-6W-L	65'
FHUPS1-UNV-25L-SD	65'
FHSCP-UNV-10P-S-SD	20'
FHSAC1-UNV-70S	20'

Dimensions are in mm (in)