

FEATURES

- Selectable 2-, 3-, or 4-phase operation at up to 1 MHz per phase
- ±14.5 mV worst-case differential sensing error over temperature
- Logic-level PWM outputs for interface to external high power drivers
- PWM Flex-Mode™ architecture for excellent load transient performance
- Active current balancing between all output phases
- Built-in power good/crowbar blanking supports on-the-fly VID code changes
- 6-bit digitally programmable 0.8375 V to 1.6 V output
- Programmable short circuit protection with programmable latch-off delay

APPLICATIONS

- Desktop PC power supplies for Next-generation Intel® processors VRM modules
- Games consoles

GENERAL DESCRIPTION

The ADP3191/ADP3191A¹ are highly efficient, multiphase, synchronous buck switching regulator controllers optimized for converting a 5 V or 12 V main supply into the core supply voltage required by high performance Intel processors. They use an internal 6-bit DAC to read a voltage identification (VID) code directly from the processor, which is used to set the output voltage between 0.8375 V and 1.6 V. The devices use a multimode PWM architecture to drive the logic-level outputs at a programmable switching frequency that can be optimized for VR size and efficiency. The phase relationship of the output signals can be programmed to provide 2-, 3-, or 4-phase operation, allowing for the construction of up to four complementary buck switching stages.

The ADP3191/ADP3191A also include programmable, no-load offset and slope functions to adjust the output voltage as a function of the load current, so it is always optimally positioned for a system transient. The ADP3191/ADP3191A also provide accurate and reliable short-circuit protection, adjustable current limiting, and a delayed power good output that accommodates on-the-fly output voltage changes requested by the CPU.

¹ Protected by U. S. Patent Number 6,683,441; other patents pending.

Rev. 0

Information furnished by Analog Devices is believed to be accurate and reliable. However, no responsibility is assumed by Analog Devices for its use, nor for any infringements of patents or other rights of third parties that may result from its use. Specifications subject to change without notice. No license is granted by implication or otherwise under any patent or patent rights of Analog Devices. Trademarks and registered trademarks are the property of their respective owners.

FUNCTIONAL BLOCK DIAGRAM

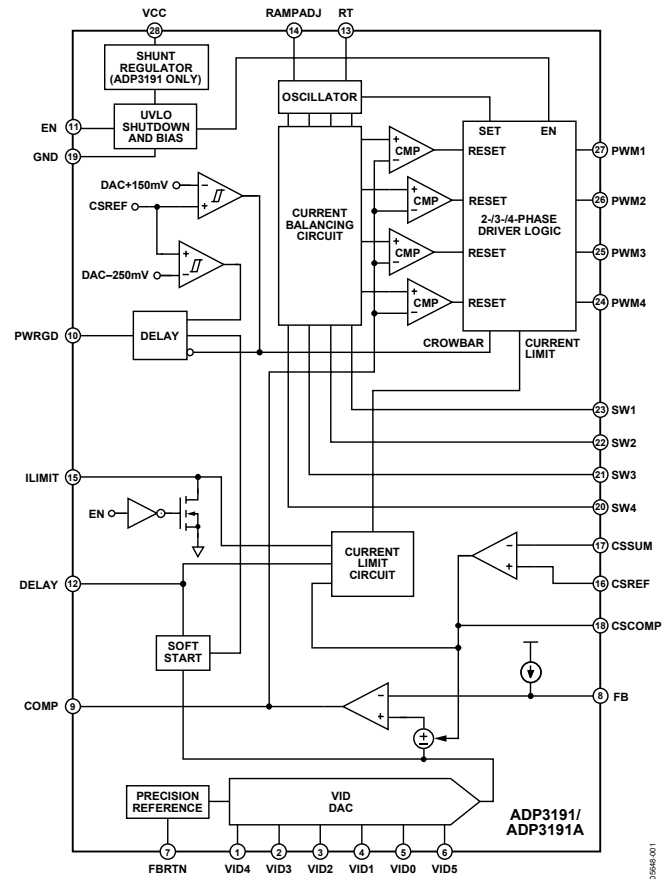

Figure 1.

The ADP3191 is a replacement for the ADP3181. A built-in shunt regulator allows the part to be connected to the 12 V system supply through a series resistor.

The devices are specified over the commercial temperature range of 0°C to 85°C and are available in a 28-lead TSSOP and a 28-lead QSOP.

TABLE OF CONTENTS

Features	1	Soft Start and Current-Limit Latch-Off Delay Times	14
Applications.....	1	Inductor Selection	14
General Description	1	Designing an Inductor	15
Functional Block Diagram	1	Output Droop Resistance.....	15
Specifications.....	3	Inductor DCR Temperature Correction	16
Absolute Maximum Ratings.....	5	Output Offset.....	16
ESD Caution.....	5	C _{OUT} Selection	17
Pin Configuration and Function Descriptions.....	6	Power MOSFETs.....	18
Typical Performance Characteristics and Test Circuits.....	7	Ramp Resistor Selection	19
Theory of Operation	8	COMP Pin Ramp	19
Startup Sequence	8	Current-Limit Setpoint.....	19
Master Clock Frequency.....	8	Feedback Loop Compensation Design.....	19
Output Voltage Differential Sensing.....	8	C _{IN} Selection and Input Current di/dt Reduction.....	21
Output Current Sensing	8	Tuning the ADP3191/ADP3191A.....	22
Active Impedance Control Mode.....	9	Replacing the ADP3181 with the ADP3191	24
Current-Control Mode and Thermal Balance.....	9	Choosing Between the ADP3191 and the ADP3191A	24
Voltage Control Mode.....	9	RAMPADJ Filter.....	24
Soft Start	9	Shunt Resistor Design.....	25
Current-Limit, Short-Circuit, and Latch-Off Protection.....	10	Layout and Component Placement.....	26
Dynamic VID.....	10	General Recommendations.....	26
Power Good Monitoring	12	Power Circuitry Recommendations	26
Output Crowbar	12	Signal Circuitry Recommendations.....	26
Output Enable and UVLO	12	Outline Dimensions	27
Application Information.....	14	Ordering Guide	27
Setting the Clock Frequency.....	14		

REVISION HISTORY

3/06—Revision 0: Initial Version

SPECIFICATIONS

VCC = 5 V, FBRTN = GND, T_A = 0°C to +85°C, unless otherwise noted.¹

Table 1.

Parameter	Symbol	Conditions	Min	Typ	Max	Unit
ERROR AMPLIFIER						
Output Voltage Range	V _{COMP}		0		VCC	V
Accuracy	V _{FB}	Relative to nominal DAC output, referenced to FBRTN, CSSUM = CSCOMP	-14.5		+14.5	mV
Line Regulation	ΔV _{FB}	VCC = 4.75 V to 5.25 V		0.05		%
Input Bias Current	I _{FB}		14	15.5	17	μA
FBRTN Current	I _{FBRTN}			100	140	μA
Output Current	I _{O(ERR)}	FB forced to V _{OUT} - 3%		500		μA
Gain Bandwidth Product	GBW _(ERR)	COMP = FB		20		MHz
Slew Rate		C _{COMP} = 10 pF		25		V/μs
VID INPUTS						
Input Low Voltage	V _{IL(VID)}				0.4	V
Input High Voltage	V _{IH(VID)}		0.8			V
Input Current, Input Voltage Low	I _{IL(VID)}	VID(X) = 0 V		-25	-35	μA
Input Current, Input Voltage High	I _{IH(VID)}	VID(X) = 1.25 V		5	15	μA
Pull-Up Resistance	R _{VID}		35	60	85	kΩ
Internal Pull-Up Voltage			1.0	1.2		V
VID Transition Delay Time ²		VID code change to FB change	400			ns
No CPU Detection Turn-Off Delay Time ²		VID code change to 11111 to PWM going low	400			ns
OSCILLATOR						
Frequency Range ²	f _{OSC}		0.25		2	MHz
Frequency Variation	f _{PHASE}	T _A = +25°C, R _T = 225 kΩ, 4-phase	155	200	245	kHz
		T _A = +25°C, R _T = 100 kΩ, 4-phase		400		kHz
		T _A = +25°C, R _T = 30 kΩ, 4-phase		600		kHz
Output Voltage	V _{RT}	R _T = 100 kΩ to GND	1.8	2.0	2.3	V
RAMPADJ Output Voltage	V _{RAMPADJ}	RAMPADJ - FB	-50		+50	mV
RAMPADJ Input Current Range	I _{RAMPADJ}		0		100	μA
CURRENT SENSE AMPLIFIER						
Offset Voltage	V _{OS(CSA)}	CSSUM - CSREF	-3		+3	mV
Input Bias Current	I _{BIAS(CSSUM)}		-50		+50	nA
Gain Bandwidth Product	GBW _(CSA)			10		MHz
Slew Rate		C _{CSCOMP} = 10 pF		10		V/μs
Input Common-Mode Range		CSSUM and CSREF	0		3	V
Positioning Accuracy	ΔV _{FB}	See Figure 5	-77	-80	-83	mV
Output Voltage Range			0.05		VCC	V
Output Current	I _{CSCOMP}			500		μA
CURRENT BALANCE CIRCUIT						
Common-Mode Range	V _{SW(X)CM}		-600		+200	mV
Input Resistance	R _{SW(X)}	SW(X) = 0 V	12	20	28	kΩ
Input Current	I _{SW(X)}	SW(X) = 0 V	5	11	17	μA
Input Current Matching ³	ΔI _{SW(X)}	SW(X) = 0 V	-5		+5	%
CURRENT LIMIT COMPARATOR						
Output Voltage						
Normal Mode	V _{LIMIT(NM)}	EN > 0.8 V, R _{LIMIT} = 250 kΩ	2.8	3	3.3	V
In Shutdown	V _{LIMIT(SD)}	EN < 0.4 V, I _{LIMIT} = -100 μA			400	mV
Output Current, Normal Mode	I _{LIMIT(NM)}	EN > 0.8 V, R _{LIMIT} = 250 kΩ		12		μA
Maximum Output Current ²			60			μA

ADP3191

Parameter	Symbol	Conditions	Min	Typ	Max	Unit
Current Limit Threshold Voltage	V_{CL}	$V_{CSREF} - V_{CSCOMP}$, $R_{LIMIT} = 250\text{ k}\Omega$	105	125	145	mV
Current Limit Setting Ratio		V_{CL}/I_{LIMIT}		10.4		mV/ μ A
DELAY Normal Mode Voltage	$V_{DELAY(NM)}$	$R_{DELAY} = 250\text{ k}\Omega$	2.8	3	3.3	V
DELAY Overcurrent Threshold	$V_{DELAY(OC)}$	$R_{DELAY} = 250\text{ k}\Omega$	1.6	1.9	2.2	V
Latch-Off Delay Time	t_{DELAY}	$R_{DELAY} = 250\text{ k}\Omega$, $C_{DELAY} = 12\text{ nF}$		1.5		ms
SOFT START						
Output Current, Soft Start Mode	$I_{DELAY(SS)}$	During startup, $DELAY < 2.8\text{ V}$	15	20	25	μ A
Soft Start Delay Time	$t_{DELAY(SS)}$	$R_{DELAY} = 250\text{ k}\Omega$, $C_{DELAY} = 12\text{ nF}$, VID code = 011111		1		ms
ENABLE INPUT						
Input Low Voltage	$V_{IL(EN)}$				0.4	V
Input High Voltage	$V_{IH(EN)}$		0.8			V
Input Current	$I_{IL(EN)}$		-1		+1	μ A
POWER GOOD COMPARATOR						
Undervoltage Threshold	$V_{PWRGD(UV)}$	Relative to nominal DAC output	-180	-250	-300	mV
Overshoot Threshold	$V_{PWRGD(OV)}$	Relative to nominal DAC output	230	300	370	mV
Output Low Voltage	$V_{OL(PWRGD)}$	$I_{PWRGD(SINK)} = 4\text{ mA}$		225	400	mV
Power Good Delay Time During Soft Start		$R_{DELAY} = 250\text{ k}\Omega$, $C_{DELAY} = 12\text{ nF}$, VID code = 011111	1			ms
VID Code Changing			100	250		μ s
VID Code Static				200		ns
Crowbar Trip Point	$V_{CROWBAR}$	Relative to nominal DAC output	270	300	350	mV
Crowbar Reset Point		Relative to FBRTN	620	730	840	mV
Crowbar Delay Time VID Code Changing	$t_{CROWBAR}$	Overshoot to PWM going low	100	250		μ s
VID Code Static		Blanking time		400		ns
PWM OUTPUTS						
Output Low Voltage	$V_{OL(PWM)}$	$I_{PWM(SINK)} = -400\text{ }\mu\text{A}$		160	500	mV
Output High Voltage	$V_{OH(PWM)}$	$I_{PWM(SOURCE)} = +400\text{ }\mu\text{A}$	4.0	5		V
SUPPLY—ADP3191						
VCC	VCC	$V_{SYSTEM} = 12\text{ V}$, $R_{SHUNT} = 300\text{ }\Omega$, see Figure 4	4.75	5		V
DC Supply Current				20	30	mA
UVLO Threshold Voltage	V_{UVLO}	VCC rising	6.3	7	8.0	V
UVLO Hysteresis				0.9		V
SUPPLY—ADP3191A						
VCC	VCC	$V_{SYSTEM} = 5\text{ V}$, $R_{SHUNT} = 10\text{ }\Omega$, see Figure 4	4.75	5		V
DC Supply Current				7	12	mA
UVLO Threshold Voltage	V_{UVLO}	VCC rising	3.7	4.0	4.3	V
UVLO Hysteresis				0.9		V

¹ All limits at temperature extremes are guaranteed via correlation using standard statistical quality control (SQC).

² Guaranteed by design, not production tested.

³ Relative current matching from each phase to the average of all four phases.

ABSOLUTE MAXIMUM RATINGS

Table 2.

Parameter	Rating
VCC	-0.3 V to +6 V
VID Pins	-0.3 V to +6 V
FBRTN	-0.3 V to +0.3 V
SW1 to SW4	-5 V to +25 V
All Other Inputs and Outputs	-0.3 V to VCC + 0.3 V
Storage Temperature Range	-65°C to +150°C
Operating Ambient Temperature Range	0°C to +85°C
Operating Junction Temperature	125°C
Thermal Impedance (θ_{JA})	100°C/W
Lead Temperature	
Soldering (10 sec)	300°C
Vapor Phase (60 sec)	215°C
Infrared (15 sec)	220°C

Stresses above those listed under Absolute Maximum Ratings may cause permanent damage to the device. This is a stress rating only; functional operation of the device at these or any other conditions above those indicated in the operational section of this specification is not implied. Exposure to absolute maximum rating conditions for extended periods may affect device reliability.

Absolute maximum ratings apply individually only, not in combination. Unless otherwise specified, all other voltages are referenced to GND.

ESD CAUTION

ESD (electrostatic discharge) sensitive device. Electrostatic charges as high as 4000 V readily accumulate on the human body and test equipment and can discharge without detection. Although this product features proprietary ESD protection circuitry, permanent damage may occur on devices subjected to high energy electrostatic discharges. Therefore, proper ESD precautions are recommended to avoid performance degradation or loss of functionality.



PIN CONFIGURATION AND FUNCTION DESCRIPTIONS

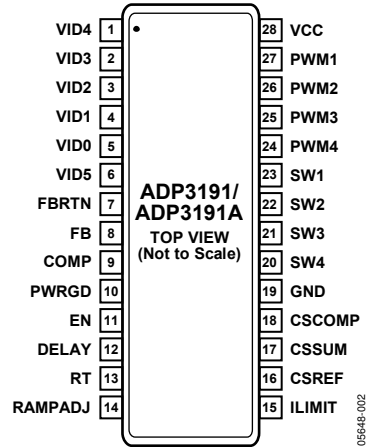

Figure 2. Pin Configuration

Table 3. Pin Function Descriptions

Pin No.	Mnemonic	Description
1 to 6	VID4 to VID0, VID5	Voltage Identification DAC Inputs. These six pins are pulled up to an internal reference, providing a Logic 1 if left open. When in normal operation mode, the DAC output programs the FB regulation voltage from 0.8375 V to 1.6 V (see Table 2). Leaving all the VID pins open results in ADP3191/ADP3191A going into a “No CPU” mode, shutting off their PWM outputs and pulling the PWRGD output low.
7	FBRTN	Feedback Return. VID DAC and error amplifier reference for remote sensing of the output voltage.
8	FB	Feedback Input. Error amplifier input for remote sensing of the output voltage. An external resistor between this pin and the output voltage sets the no-load offset point.
9	COMP	Error Amplifier Output and Compensation Point.
10	PWRGD	Power Good Output. Open-drain output that signals when the output voltage is outside of the proper operating range.
11	EN	Power Supply Enable Input. Pulling this pin to GND disables the PWM outputs and pulls the PWRGD output low.
12	DELAY	Soft Start Delay and Current-Limit Latch-Off Delay Setting Input. An external resistor and capacitor connected between this pin and GND sets the soft start ramp-up time and the overcurrent latch-off delay time.
13	RT	Frequency Setting Resistor Input. An external resistor connected between this pin and GND sets the oscillator frequency of the device.
14	RAMPADJ	PWM Ramp Current Input. An external resistor from the converter input voltage to this pin sets the internal PWM ramp.
15	ILIMIT	Current Limit Set Point/Enable Output. An external resistor from this pin to GND sets the current limit threshold of the converter. This pin is actively pulled low when the ADP3191/ADP3191A EN input is low or when VCC is below its UVLO threshold to signal to the driver IC that the driver high-side and low-side outputs should go low.
16	CSREF	Current Sense Reference Voltage Input. The voltage on this pin is used as the reference for the current sense amplifier and the power good and crowbar functions. This pin should be connected to the common point of the output inductors.
17	CSSUM	Current Sense Summing Node. External resistors from each switch node to this pin sum the average inductor currents together to measure the total output current.
18	CSCOMP	Current Sense Compensation Point. A resistor and capacitor from this pin to CSSUM determine the slope of the load line and the positioning loop response time.
19	GND	Ground. All internal biasing and the logic output signals of the device are referenced to this ground.
20 to 23	SW4 to SW1	Current Balance Inputs. Inputs for measuring the current level in each phase. The SW pins of unused phases should be left open.
24 to 27	PWM4 to PWM1	Logic Level PWM Outputs. Each output is connected to the input of an external MOSFET driver such as the ADP3110A . Connecting the PWM3 and/or PWM4 outputs to GND causes that phase to turn off, allowing the ADP3191/ADP3191A to operate as a 2-, 3-, or 4-phase controller.
28	VCC	ADP3191: A 240 Ω resistor should be placed between the 12 V system supply and the VCC pin to ensure 5 V. ADP3191A: A 10 Ω resistor should be placed between the 5 V system supply and the VCC pin to ensure 5 V.

TYPICAL PERFORMANCE CHARACTERISTICS AND TEST CIRCUITS

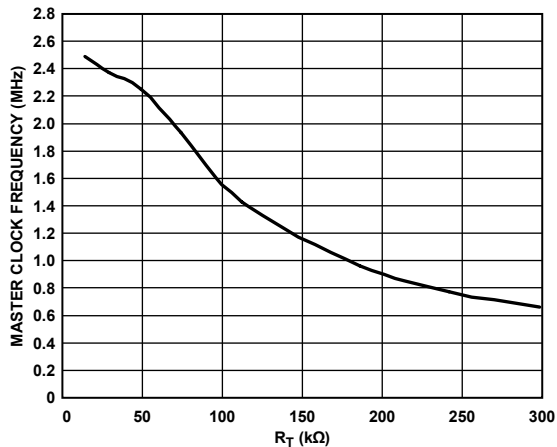

Figure 3. Master Clock Frequency vs. R_T

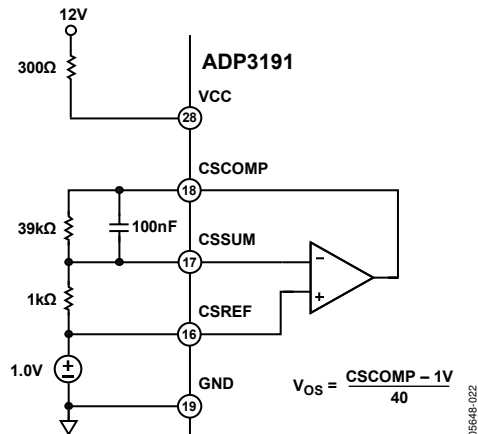

Figure 5. Current Sense Amplifier V_{OS}

$$V_{OS} = \frac{CSCOMP - 1V}{40}$$

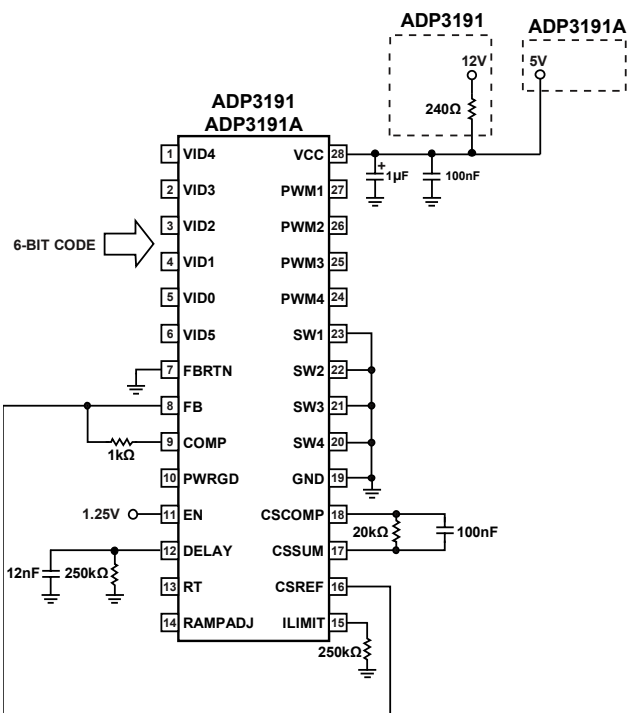
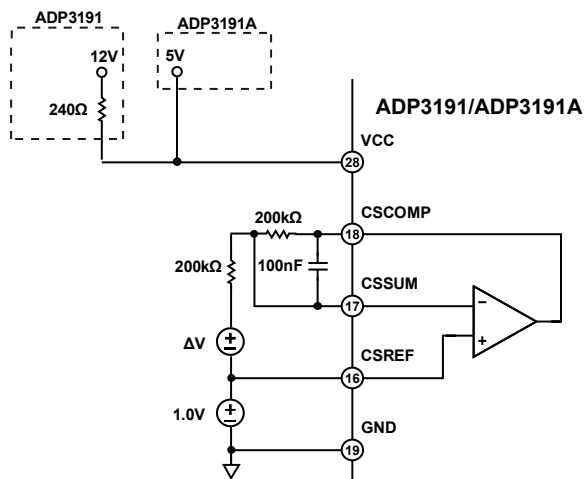

Figure 4. Closed-Loop Output Voltage Accuracy



$$\Delta V_{FB} = FB_{\Delta V} = 80mV - FB_{\Delta V} = 0mV$$

Figure 6. Positioning Voltage

THEORY OF OPERATION

The ADP3191/ADP3191A combine a multimode, fixed frequency PWM control with multiphase logic outputs for use in 2-, 3-, and 4-phase synchronous buck CPU core supply power converters. The internal VID DAC is designed to interface with the Intel 6-bit VRD/VRM 10- and 10.1-compatible CPUs. Multiphase operation is important for producing the high currents and low voltages demanded by today's microprocessors. Handling the high currents in a single-phase converter places high thermal demands on the components in the system, such as the inductors and MOSFETs.

The multimode control of the ADP3191/ADP3191A ensures a stable, high performance topology for

- Balancing currents and thermals between phases
- High speed response at the lowest possible switching frequency and output decoupling
- Minimizing thermal switching losses due to lower frequency operation
- Tight load line regulation and accuracy
- High current output for up to 4-phase operation
- Reduced output ripple due to multiphase cancellation
- PC board layout noise immunity
- Ease of use and design due to independent component selection
- Flexibility in operation for tailoring design to low cost or high performance

STARTUP SEQUENCE

During startup, the number of operational phases and their phase relationship is determined by the internal circuitry that monitors the PWM outputs. Normally, the ADP3191/ADP3191A operate as a 4-phase PWM controller. Grounding the PWM4 pin programs 3-phase operation, and grounding the PWM3 pin and the PWM4 pin programs 2-phase operation.

When the ADP3191/ADP3191A are enabled, the controller outputs a voltage on PWM3 and PWM4 that is approximately 675 mV. An internal comparator checks each pin's voltage vs. a threshold of 300 mV. If the pin is grounded, it is below the threshold, and the phase is disabled. The output resistance of the PWM pins is approximately 5 k Ω during this detection time. Any external pull-down resistance connected to the PWM pins should not be less than 25 k Ω to ensure proper operation. PWM1 and PWM2 are disabled during the phase detection interval, which occurs during the first two clock cycles of the internal oscillator.

After this time, if the PWM output is not grounded, the 5 k Ω resistance is removed, and it switches between 0 V and 5 V.

If the PWM output is grounded, it remains off. The PWM outputs are logic-level devices intended for driving external gate drivers, such as the [ADP3110A](#). Because each phase is monitored independently, operation approaching 100% duty cycle is possible. Also, more than one output can be on at the same time for overlapping phases.

MASTER CLOCK FREQUENCY

The clock frequency of the ADP3191/ADP3191A is set with an external resistor connected from the RT pin to ground. The frequency follows the graph in Figure 3. To determine the frequency per phase, the clock is divided by the number of phases in use. If PWM4 is grounded, divide the master clock by 3 for the frequency of the remaining phases. If PWM3 and PWM4 are grounded, divide by 2. If all phases are in use, divide by 4.

OUTPUT VOLTAGE DIFFERENTIAL SENSING

The ADP3191/ADP3191A differential sense compares a high accuracy VID DAC and a precision reference to implement a low offset error amplifier. This maintains a worst-case specification of ± 9.5 mV differential sensing error over their full operating output voltage and temperature range. The output voltage is sensed between the FB pin and the FBRTN pin. FB should be connected through a resistor to the regulation point, usually the remote sense pin of the microprocessor. FBRTN should be connected directly to the remote sense ground point. The internal VID DAC and precision reference are referenced to FBRTN, which has a minimal current of 100 μ A to allow accurate remote sensing. The internal error amplifier compares the output of the DAC to the FB pin to regulate the output voltage.

OUTPUT CURRENT SENSING

The ADP3191/ADP3191A provide a dedicated current sense amplifier (CSA) to monitor the total output current for proper voltage positioning vs. load current and for current-limit detection. Sensing the load current at the output gives the total average current being delivered to the load. This is an inherently more accurate method than peak current detection or sampling the current across a sense element such as the low-side MOSFET. This amplifier can be configured several ways, depending on the objectives of the system:

- Output inductor DCR sensing without a thermistor for lowest cost
- Output inductor DCR sensing with a thermistor for improved accuracy with tracking of inductor temperature
- Sense resistors for highest accuracy measurements

The positive input of the CSA is connected to the CSREF pin, which is connected to the output voltage. The inputs to the amplifier are summed together through resistors from the sensing element (such as the switch node side of the output inductors) to the inverting input, CSSUM. The feedback resistor between CSCOMP and CSSUM sets the gain of the amplifier, and a filter capacitor is placed in parallel with this resistor. The gain of the amplifier is programmable by adjusting the feedback resistor to set the load line required by the microprocessor. The current information is then given as the difference of CSREF – CSCOMP. This difference signal is used internally to offset the VID DAC for voltage positioning and as a differential input for the current-limit comparator.

To provide the best accuracy for sensing current, the CSA is designed to have a low offset input voltage. Also, the sensing gain is determined by external resistors, so it can be made extremely accurate.

ACTIVE IMPEDANCE CONTROL MODE

For controlling the dynamic output voltage droop as a function of output current, a signal proportional to the total output current at the CSCOMP pin can be scaled to equal the droop impedance of the regulator multiplied by the output current. This droop voltage is then used to set the input control voltage to the system. The droop voltage is subtracted from the DAC reference input voltage directly to tell the error amplifier where the output voltage should be. This differs from previous implementations and allows enhanced feed-forward response.

CURRENT-CONTROL MODE AND THERMAL BALANCE

The ADP3191/ADP3191A have individual inputs for each phase, which are used for monitoring the current in each phase. This information is combined with an internal ramp to create a current balancing feedback system, which has been optimized for initial current balance accuracy and dynamic thermal balancing during operation. This current balance information is independent of the average output current information used for positioning described previously.

The magnitude of the internal ramp can be set to optimize the transient response of the system. It also monitors the supply voltage for feed-forward control for changes in the supply. A resistor connected from the power input voltage to the RAMPADJ pin determines the slope of the internal PWM ramp. Detailed information about programming the ramp is given in the Application Information section.

External resistors can be placed in series with individual phases to create, if desired, an intentional current imbalance, such as when one phase has better cooling and can support higher currents. Resistor R_{SW1} through Resistor R_{SW4} (see the typical application circuit in Figure 9) can be used for adjusting thermal balance. It is best to have the ability to add these resistors during the initial design, so make sure that placeholders are provided in the layout.

To increase the current in any given phase, make R_{SW} for this phase larger (make $R_{SW} = 0$ for the hottest phase, and do not change during balancing). Increasing R_{SW} to only 500 Ω makes a substantial increase in phase current. Increase each R_{SW} value by small amounts to achieve balance, starting with the coolest phase first.

VOLTAGE CONTROL MODE

A high gain bandwidth voltage mode error amplifier is used for the voltage-mode control loop. The control input voltage to the positive input is set via the VID logic according to the voltages listed in Table 4. This voltage is also offset by the droop voltage for active positioning of the output voltage as a function of current, commonly known as active voltage positioning. The output of the amplifier is the COMP pin, which sets the termination voltage for the internal PWM ramps.

The negative input (FB) is tied to the output sense location with a resistor (R_B) and is used for sensing and controlling the output voltage at this point. A current source from the FB pin flowing through R_B is used for setting the no-load offset voltage from the VID voltage. The no-load voltage is negative with respect to the VID DAC. The main loop compensation is incorporated into the feedback network between FB and COMP.

SOFT START

The power-on ramp-up time of the output voltage is set with a capacitor and resistor in parallel from the DELAY pin to ground. The RC time constant also determines the current-limit latch-off time. In UVLO, or when EN is a logic low, the DELAY pin is held at ground. After the UVLO threshold is reached and EN is a logic high, the DELAY capacitor is charged with an internal 20 μ A current source. The output voltage follows the ramping voltage on the DELAY pin, limiting the inrush current. The soft start time depends on the value of the VID DAC and C_{DLY} , with a secondary effect from R_{DLY} . Refer to the Application Information section for detailed information on setting C_{DLY} .

If EN is taken low or if VCC drops below UVLO, the DELAY capacitor is reset to ground to be ready for another soft start cycle. Figure 7 shows a typical soft start sequence for the ADP3191/ADP3191A.

ADP3191

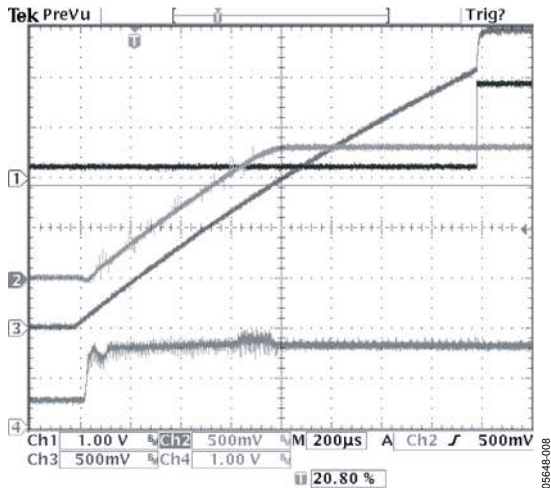

Figure 7. Typical Start-Up Waveforms
Channel 1: PWRGD, Channel 2: CSREF,
Channel 3: DELAY, Channel 4: COMP

CURRENT-LIMIT, SHORT-CIRCUIT, AND LATCH-OFF PROTECTION

The ADP3191/ADP3191A compare a programmable current-limit setpoint to the voltage from the output of the current sense amplifier. The level of current limit is set with the resistor from the ILIMIT pin to ground. During normal operation, the voltage on ILIMIT is 3 V. The current through the external resistor is internally scaled to give a current-limit threshold of 10.4 mV/µA. If the difference in voltage between CSREF and CSCOMP rises above the current-limit threshold, the internal current-limit amplifier controls the internal COMP voltage to maintain the average output current at the limit.

After the limit is reached, the 3 V pull-up on the DELAY pin is disconnected, and the external delay capacitor is discharged through the external resistor. A comparator monitors the DELAY voltage and shuts off the controller when the voltage drops below 1.8 V. The current-limit latch-off delay time is, therefore, set by the RC time constant discharging from 3 V to 1.8 V. The Application Information section discusses the selection of C_{DLY} and R_{DLY} .

Because the controller continues to cycle the phases during the latch-off delay time, the controller returns to normal operation if the short is removed before the 1.8 V threshold is reached. The recovery characteristic depends on the state of PWRGD. If the output voltage is within the PWRGD window, the controller resumes normal operation. However, if a short circuit has caused the output voltage to drop below the PWRGD threshold, a soft start cycle is initiated.

The latch-off function can be reset by either removing and reapplying VCC to the ADP3191/ADP3191A or by pulling the EN pin low for a short time. To disable the short-circuit latch-off function, the external resistor to ground should be left open, and a high value (>1 MΩ) resistor should be connected from DELAY to VCC.

This prevents the DELAY capacitor from discharging, so the 1.8 V threshold is never reached. The resistor has an impact on the soft start time because the current through it adds to the internal 20 µA current source.

During startup, when the output voltage is below 200 mV, a secondary current limit is active. This is necessary because the voltage swing of CSCOMP cannot go below ground. This secondary current limit controls the internal COMP voltage to the PWM comparators to 2 V. This limits the voltage drop across the low-side MOSFETs through the current balance circuitry.

An inherent per phase current limit protects individual phases, if one or more phases stop functioning because of a faulty component. This limit is based on the maximum normal mode COMP voltage.

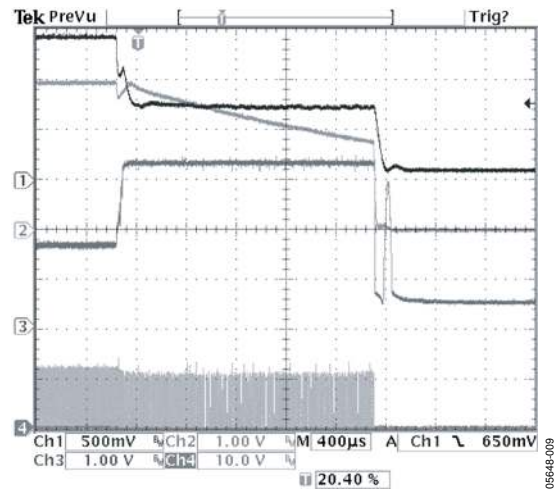

Figure 8. Overcurrent Latch-Off Waveforms
Channel 1: CSREF, Channel 2: DELAY,
Channel 3: COMP, Channel 4: Phase 1 Switch Node

DYNAMIC VID

The ADP3191/ADP3191A have the ability to dynamically change the VID input while the controller is running. This allows the output voltage to change while the supply is running and supplying current to the load. This is commonly referred to as VID on-the-fly (OTF). A VID OTF can occur under either light or heavy load conditions. The processor signals the controller by changing the VID inputs in multiple steps from the start code to the finish code. This change can be positive or negative.

When a VID input changes state, the ADP3191/ADP3191A detect the change and ignore the DAC inputs for a minimum of 400 ns. This time prevents a false code due to logic skew while the six VID inputs are changing. Additionally, the first VID change initiates the PWRGD and crowbar blanking functions for a minimum of 100 µs to prevent a false PWRGD or crowbar event. Each VID change resets the internal timer.

Table 4. VID Codes for the ADP3191/ADP3191A

VID4	VID3	VID2	VID1	VID0	VID5	Output
1	1	1	1	1	1	No CPU
1	1	1	1	1	0	No CPU
0	1	0	1	0	0	0.8375 V
0	1	0	0	1	1	0.8500 V
0	1	0	0	1	0	0.8625 V
0	1	0	0	0	1	0.8750 V
0	1	0	0	0	0	0.8875 V
0	0	1	1	1	1	0.9000 V
0	0	1	1	1	0	0.9125 V
0	0	1	1	0	1	0.9250 V
0	0	1	1	0	0	0.9375 V
0	0	1	0	1	1	0.9500 V
0	0	1	0	1	0	0.9625 V
0	0	1	0	0	1	0.9750 V
0	0	1	0	0	0	0.9875 V
0	0	0	1	1	1	1.0000 V
0	0	0	1	1	0	1.0125 V
0	0	0	1	0	1	1.0250 V
0	0	0	1	0	0	1.0375 V
0	0	0	0	1	1	1.0500 V
0	0	0	0	1	0	1.0625 V
0	0	0	0	0	1	1.0750 V
0	0	0	0	0	0	1.0875 V
1	1	1	1	0	1	1.1000 V
1	1	1	1	0	0	1.1125 V
1	1	1	0	1	1	1.1250 V
1	1	1	0	1	0	1.1375 V
1	1	1	0	0	1	1.1500 V
1	1	1	0	0	0	1.1625 V
1	1	0	1	1	1	1.1750 V
1	1	0	1	1	0	1.1875 V
1	1	0	1	0	1	1.2000 V

VID4	VID3	VID2	VID1	VID0	VID5	Output
1	1	0	1	0	0	1.2125 V
1	1	0	0	1	1	1.2250 V
1	1	0	0	1	0	1.2375 V
1	1	0	0	0	1	1.2500 V
1	1	0	0	0	0	1.2625 V
1	0	1	1	1	1	1.2750 V
1	0	1	1	1	0	1.2875 V
1	0	1	1	0	1	1.3000 V
1	0	1	1	0	0	1.3125 V
1	0	1	0	1	1	1.3250 V
1	0	1	0	1	0	1.3375 V
1	0	1	0	0	1	1.3500 V
1	0	1	0	0	0	1.3625 V
1	0	0	1	1	1	1.3750 V
1	0	0	1	1	0	1.3875 V
1	0	0	1	0	1	1.4000 V
1	0	0	1	0	0	1.4125 V
1	0	0	0	1	1	1.4250 V
1	0	0	0	1	0	1.4375 V
1	0	0	0	0	1	1.4500 V
1	0	0	0	0	0	1.4625 V
0	1	1	1	1	1	1.4750 V
0	1	1	1	1	0	1.4875 V
0	1	1	1	0	1	1.5000 V
0	1	1	1	0	0	1.5125 V
0	1	1	0	1	1	1.5250 V
0	1	1	0	1	0	1.5375 V
0	1	1	0	0	1	1.5500 V
0	1	1	0	0	0	1.5625 V
0	1	0	1	1	1	1.5750 V
0	1	0	1	1	0	1.5875 V
0	1	0	1	0	1	1.6000 V

POWER GOOD MONITORING

The power good comparator monitors the output voltage via the CSREF pin. The PWRGD pin is an open-drain output whose high level (when connected to a pull-up resistor) indicates that the output voltage is within the nominal limits specified in Table 4. These limits are based on the VID voltage setting. PWRGD goes low if the output voltage is outside of this specified range, if all of the VID DAC inputs are high, or whenever the EN pin is pulled low. PWRGD is blanked during a VID OTF event for a period of 250 μ s to prevent false signals during the time the output is changing.

The PWRGD circuitry also incorporates an initial turn-on delay time based on the DELAY ramp. The PWRGD pin is held low until the DELAY pin reaches 2.6 V. The time between when the PWRGD undervoltage threshold is reached and when the DELAY pin reaches 2.6 V provides the turn-on delay time. This time is incorporated into the soft start ramp. To ensure a 1 ms delay time on PWRGD, the soft start ramp must also be >1 ms. Refer to the Application Information section for detailed information on setting C_{DLY} .

OUTPUT CROWBAR

As part of the protection for the load and output components of the supply, the PWM outputs are driven low (turning on the low-side MOSFETs) when the output voltage exceeds the upper crowbar threshold. This crowbar action stops once the output voltage falls below the release threshold of approximately 550 mV.

Turning on the low-side MOSFETs pulls down the output as the reverse current builds up in the inductors. If the output over-voltage is due to a short in the high-side MOSFET, this action current-limits the input supply or blows its fuse, protecting the microprocessor from being destroyed.

OUTPUT ENABLE AND UVLO

For the ADP3191/ADP3191A to begin switching, the input supply (VCC) to the controller must be higher than the UVLO threshold, and the EN pin must be higher than its logic threshold. If UVLO is less than the threshold or the EN pin is a logic low, the ADP3191/ADP3191A are disabled. This holds the PWM outputs at ground, shorts the DELAY capacitor to ground, and holds the ILIMIT pin at ground.

In the application circuit, the ILIMIT pin should be connected to the OD pins of the ADP3110 drivers. The ILIMIT being grounded disables the drivers, so that both the DRVH and DRVL are grounded. This feature is important in preventing the discharge of the output capacitors when the controller is shut off. If the driver outputs were not disabled, a negative voltage could be generated during output due to the high current discharge of the output capacitors through the inductors.

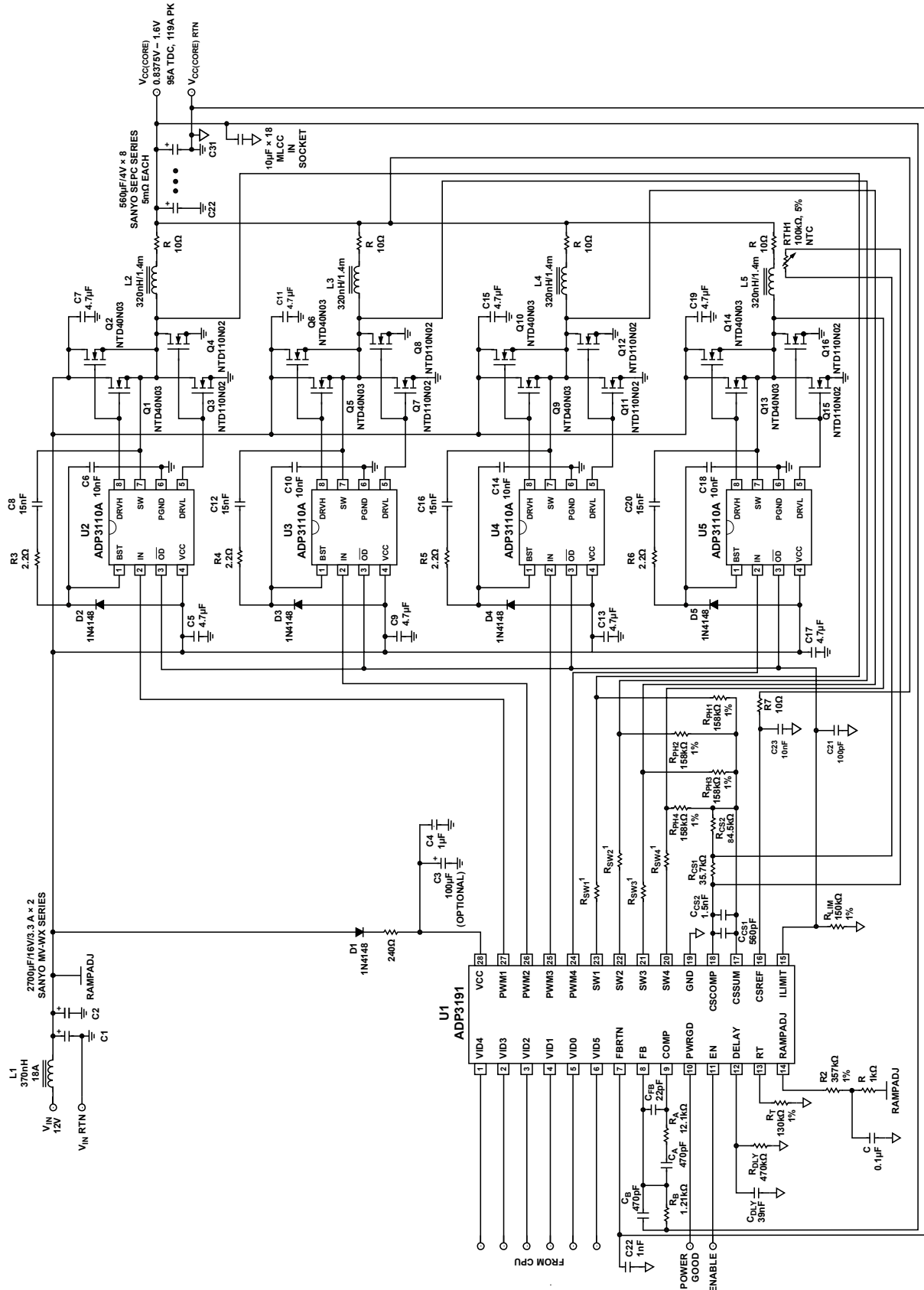

¹FOR A DESCRIPTION OF OPTIONAL R_{SW} RESISTORS, SEE THE THEORY OF OPERATION SECTION.

Figure 9. Typical VR101 Applications Schematic (ADP3191 Only; See Figure 18 for ADP3191A Connections)

APPLICATION INFORMATION

The design parameters for a typical Intel VRD 10.1-compliant CPU application are as follows:

- Input voltage (V_{IN}) = 12 V
- VID setting voltage (V_{VID}) = 1.300 V
- Duty cycle (D) = 0.108
- Nominal output voltage at no load (V_{ONL}) = 1.281 V
- Nominal output voltage at 101 A load (V_{OFL}) = 1.180 V
- Static output voltage drop based on a 1.0 m Ω load line (R_O) from no load to full load (V_D) = $V_{ONL} - V_{OFL} = 1.281 \text{ V} - 1.180 \text{ V} = 101 \text{ mV}$
- Maximum output current (I_O) = 119 A
- Maximum output current step (ΔI_O) = 95 A
- Number of phases (n) = 4
- Switching frequency per phase (f_{SW}) = 330 kHz

SETTING THE CLOCK FREQUENCY

The ADP3191/ADP3191A use a fixed-frequency control architecture. The frequency is set by an external timing resistor (R_T). The clock frequency and the number of phases determine the switching frequency per phase, which relates directly to switching losses and the sizes of the inductors and/or the input and output capacitors. With $n = 4$ for four phases, a clock frequency of 1.32 MHz sets the switching frequency (f_{sw}) of each phase to 330 kHz, which represents a practical trade-off between the switching losses and the sizes of the output filter components. Figure 3 shows that to achieve 1.32 MHz oscillator frequency, the correct value for R_T is 130 k Ω . Alternatively, the value for R_T can be calculated using

$$R_T = \frac{1}{n \times f_{SW} \times 4.7 \text{ pF}} - 31 \text{ k}\Omega \quad (1)$$

where 4.7 pF and 31 k Ω are internal IC component values. For good initial accuracy and frequency stability, a 1% resistor is recommended.

SOFT START AND CURRENT-LIMIT LATCH-OFF DELAY TIMES

Because the soft start and current-limit latch-off delay functions share the DELAY pin, these two parameters must be considered together. The first step is to set C_{DLY} for the soft start ramp. This ramp is generated with a 20 μA internal current source. The value of R_{DLY} has a second-order impact on the soft start time because it sinks part of the current source to ground.

However, as long as R_{DLY} is kept greater than 200 k Ω , this effect is minor. The value for C_{DLY} can be approximated using

$$C_{DLY} = \left(20 \mu\text{A} - \frac{V_{VID}}{2 \times R_{DLY}} \right) \times \frac{t_{SS}}{V_{VID}} \quad (2)$$

where t_{SS} is the desired soft start time. Assuming an R_{DLY} of 390 k Ω and a desired soft start time of 3 ms, C_{DLY} is 36 nF. The closest standard value for C_{DLY} is 39 nF. Once C_{DLY} is chosen, R_{DLY} can be calculated for the current-limit latch-off time using

$$R_{DLY} = \frac{1.96 \times t_{DELAY}}{C_{DLY}} \quad (3)$$

If the result for R_{DLY} is less than 200 k Ω , a smaller soft start time should be considered by recalculating the equation for C_{DLY} , or a longer latch-off time should be used. R_{DLY} should never be less than 200 k Ω . In this example, a delay time of 9 ms results in $R_{DLY} = 452 \text{ k}\Omega$. The closest standard 5% value is 470 k Ω .

INDUCTOR SELECTION

The choice of inductance for the inductor determines the ripple current in the inductor. Less inductance leads to more ripple current, which increases the output ripple voltage and conduction losses in the MOSFETs. But it also allows using smaller inductors and, for a specified peak-to-peak transient deviation, less total output capacitance.

Conversely, a higher inductance means lower ripple current and reduced conduction losses but requires larger inductors and more output capacitance for the same peak-to-peak transient deviation. In any multiphase converter, a practical value for the peak-to-peak inductor ripple current is less than 50% of the maximum dc current in the same inductor. Equation 4 shows the relationship between the inductance, oscillator frequency, and peak-to-peak ripple current in the inductor.

$$I_R = \frac{V_{VID} \times (1-D)}{f_{SW} \times L} \quad (4)$$

Equation 5 can be used to determine the minimum inductance based on a given output ripple voltage.

$$L \geq \frac{V_{VID} \times R_O \times (1 - (n \times D))}{f_{SW} \times V_{RIPPLE}} \quad (5)$$

Solving Equation 5 for a 10 mV p-p output ripple voltage yields

$$L \geq \frac{1.3 \text{ V} \times 1.0 \text{ m}\Omega \times (1 - 0.432)}{330 \text{ kHz} \times 10 \text{ mV}} = 224 \text{ nH}$$

If the resulting ripple voltage is less than it was designed for, make the inductor smaller until the ripple value is met. This allows optimal transient response and minimum output decoupling.

The smallest possible inductor should be used to minimize the number of output capacitors. For this example, choosing a 320 nH inductor is a good starting point and gives a calculated ripple current of 11 A. The inductor should not saturate at the peak current of 35.5 A and should be able to handle the sum of the power dissipation caused by the average current of 30 A in the winding and core loss.

Another important factor in the inductor design is the DCR, which is used for measuring the phase currents. A large DCR can cause excessive power losses, while too small a value can lead to increased measurement error. A good rule is to have the DCR be about 1 to 1½ times the droop resistance (R_O). For this design, an inductor with a DCR of 1.4 mΩ is used.

DESIGNING AN INDUCTOR

Once the inductance and DCR are known, the next step is either to design an inductor or to find a standard inductor that comes as close as possible to meeting the overall design goals. It is also important to have the inductance and DCR tolerance specified to control the accuracy of the system. 15% inductance and 8% DCR (at room temperature) are reasonable tolerances most manufacturers can meet.

The first decision in designing the inductor is to choose the core material. Several possibilities for providing low core loss at high frequencies include the powder cores (for example, Kool-Mμ from Magnetics, Inc. or from Micrometals) and the gapped soft ferrite cores (for example, 3F3 or 3F4 from Philips). Low frequency powdered iron cores should be avoided due to their high core loss, especially when the inductor value is relatively low and the ripple current is high.

The best choice for a core geometry is a closed-loop type such as a potentiometer core, PQ, U, or E core or toroid. A good compromise between price and performance is a core with a toroidal shape.

Many useful magnetics design references are available for quickly designing a power inductor, such as

- Magnetic Designer Software Intusoft (www.intusoft.com)
- *Designing Magnetic Components for High-Frequency DC-DC Converters*, by William T. McLyman, KG Magnetics, Inc., ISBN 1883107008

Selecting a Standard Inductor

The following power inductor manufacturers can provide design consultation and deliver power inductors optimized for high power applications upon request:

- Coilcraft
www.coilcraft.com
- Sumida Electric Company
www.sumida.com
- Vishay Intertechnology
www.vishay.com

OUTPUT DROOP RESISTANCE

The design requires the regulator output voltage measured at the CPU pins to drop when the output current increases. The specified voltage drop corresponds to a dc output resistance (R_O).

The output current is measured by summing the voltage across each inductor and passing the signal through a low-pass filter. This summer filter is the CS amplifier configured with $R_{PH(x)}$ (summers), R_{CS} , and C_{CS} (filter). The output resistance of the regulator is set by the following equations, where R_L is the DCR of the output inductors:

$$R_O = \frac{R_{CS}}{R_{PH(x)}} \times R_L \quad (6)$$

$$C_{CS} = \frac{L}{R_L \times R_{CS}} \quad (7)$$

The user has the flexibility of choosing either R_{CS} or $R_{PH(x)}$. It is best to select R_{CS} equal to 100 kΩ and then solve for $R_{PH(x)}$ by rearranging Equation 6.

$$R_{PH(x)} = \frac{R_L}{R_O} \times R_{CS}$$

$$R_{PH(x)} = \frac{1.4 \text{ m}\Omega}{1.0 \text{ m}\Omega} \times 100 \text{ k}\Omega = 140 \text{ k}\Omega$$

Next, use Equation 6 to solve for C_{CS} .

$$C_{CS} = \frac{320 \text{ nH}}{1.4 \text{ m}\Omega \times 100 \text{ k}\Omega} = 2.28 \text{ nF}$$

It is best to have a dual location for C_{CS} in the layout, so that standard values can be used in parallel to get as close as possible to the value desired. For accuracy, C_{CS} should be a 5% or 10% NPO capacitor. This example uses a 5% combination for C_{CS} of 1.5 nF and 560 pF in parallel. Recalculating R_{CS} and $R_{PH(x)}$ using this capacitor combination yields 110 kΩ and 154 kΩ. The closest standard 1% value for $R_{PH(x)}$ is 158 kΩ.

INDUCTOR DCR TEMPERATURE CORRECTION

With the inductor's DCR being used as the sense element and copper wire being the source of the DCR, compensation is needed for temperature changes of the inductor's winding. Fortunately, copper has a well-known temperature coefficient (TC) of 0.39%/°C.

If R_{CS} is designed to have an opposite and equal percentage change in resistance to that of the wire, it cancels the temperature variation of the inductor's DCR. Due to the nonlinear nature of NTC thermistors, Resistor R_{CS1} and Resistor R_{CS2} are needed. See Figure 10 to linearize the NTC and produce the desired temperature tracking.

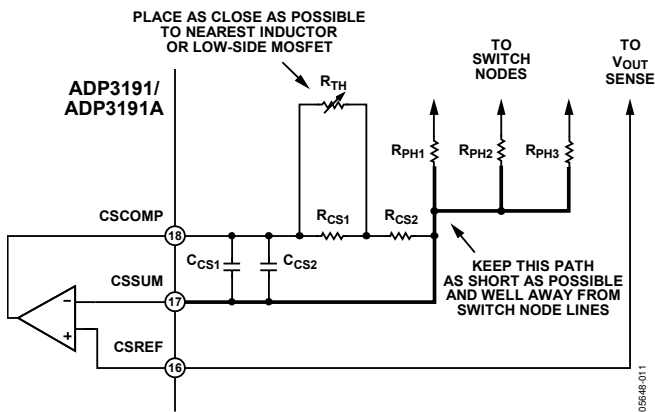

Figure 10. Temperature Compensation Circuit Values

The following procedure and expressions yield values to use for R_{CS1} , R_{CS2} , and R_{TH} (the thermistor value at 25°C) for a given R_{CS} value.

1. Select an NTC based on type and value. Because there isn't a value yet, start with a thermistor with a value close to R_{CS} . The NTC should also have an initial tolerance of better than 5%.
2. Based on the type of NTC, find its relative resistance value at two temperatures. The temperatures that work well are 50°C and 90°C. These resistance values are called A ($R_{TH(50°C)}/R_{TH(25°C)}$) and B ($R_{TH(90°C)}/R_{TH(25°C)}$). The NTC's relative value is always 1 at 25°C.
3. Find the relative values of R_{CS} required for each of these temperatures. This is based on the percentage change needed, which in this example is initially 0.39%/°C. These are called r_1 ($1/(1 + TC \times (T_1 - 25))$) and r_2 ($1/(1 + TC \times (T_2 - 25))$), where $TC = 0.0039$ for copper. $T_1 = 50°C$ and $T_2 = 90°C$ are chosen. From this, calculate that $r_1 = 0.9112$ and $r_2 = 0.7978$.

4. Compute the relative values for R_{CS1} , R_{CS2} , and R_{TH} using

$$R_{CS2} = \frac{(A - B) \times r_1 \times r_2 - A \times (1 - B) \times r_2 + B \times (1 - A) \times r_1}{A \times (1 - B) \times r_1 - B \times (1 - A) \times r_2 - (A - B)}$$

$$R_{CS1} = \frac{(1 - A)}{\frac{1}{1 - R_{CS2}} - \frac{A}{r_1 - R_{CS2}}}$$

$$R_{TH} = \frac{1}{\frac{1}{1 - R_{CS2}} - \frac{1}{R_{CS1}}} \quad (8)$$

5. Calculate $R_{TH} = r_{TH} \times R_{CS}$, then select the closest value of thermistor available. Also, compute a scaling factor k based on the ratio of the actual thermistor value used relative to the computed one:

$$k = \frac{R_{TH(ACTUAL)}}{R_{TH(CALCULATED)}} \quad (9)$$

6. Calculate values for R_{CS1} and R_{CS2} using Equation 10:

$$R_{CS1} = R_{CS} \times k \times R_{CS1}$$

$$R_{CS2} = R_{CS} \times ((1 - k) + (k \times R_{CS2})) \quad (10)$$

For this example, R_{CS} has been calculated to be 110 kΩ. Start with a thermistor value of 100 kΩ. Next, look through the available 0603-size thermistors, and find a Vishay NTHS0603N01N1003JR NTC thermistor with $A = 0.3602$ and $B = 0.09174$. From these, compute $R_{CS1} = 0.3795$, $R_{CS2} = 0.7195$, and $R_{TH} = 1.075$. Solve for R_{TH} , which yields 118.28 kΩ. Then, choose 100 kΩ, which makes $k = 0.8455$. Finally, R_{CS1} and R_{CS2} are 35.3 kΩ and 83.9 kΩ. Choose the closest 1% resistor values, which yields a choice of 35.7 kΩ or 84.5 kΩ.

OUTPUT OFFSET

The Intel specification requires that at no load should the nominal output voltage of the regulator be offset to a value lower than the nominal voltage corresponding to the VID code. The offset is set by a constant current source flowing out of the FB pin (I_{FB}) and flowing through R_B . The value of R_B can be found using Equation 11:

$$R_B = \frac{V_{VID} - V_{ONL}}{I_{FB}}$$

$$R_B = \frac{1.3 \text{ V} - 1.281 \text{ V}}{15.5 \mu\text{A}} = 1.22 \text{ k}\Omega \quad (11)$$

The closest standard 1% resistor value is 1.21 kΩ.

C_{OUT} SELECTION

The required output decoupling for the regulator is typically recommended by Intel for various processors and platforms. Also, to determine what is required, use some simple design guidelines that are based on having both bulk and ceramic capacitors in the system.

The first step is to select the total amount of ceramic capacitance. This is based on the number and type of capacitor to be used. The best location for ceramic capacitors is inside the socket, with 12 to 18 of Size 1206 being the physical limit. Additional ceramic capacitors can be placed along the outer edge of the socket as well.

Combined ceramic values of 200 μF to 300 μF are recommended, usually made up of multiple 10 μF or 22 μF capacitors. Select the number of ceramic capacitors, and find the total ceramic capacitance (C_z).

Next, there is an upper limit imposed on the total amount of bulk capacitance (C_x) when considering the VID on-the-fly voltage stepping of the output (Voltage Step V_V in Time t_v with error of V_{ERR}). A lower limit is based on meeting the capacitance for load release for a given maximum load step, ΔI_O , and a maximum allowable overshoot. The total amount of load release voltage is given as $\Delta V_O = \Delta I_O \times R_O + \Delta V_{rl}$, where ΔV_{rl} is the maximum allowable overshoot voltage.

$$C_{x(MIN)} \geq \left(\frac{L \times \Delta I_O}{n \times \left(R_O + \frac{\Delta V_{rl}}{\Delta I_O} \right) \times V_{VID}} - C_z \right) \quad (12)$$

$$C_{x(MAX)} \leq \frac{L}{nK^2 R_O^2} \times \frac{V_V}{V_{VID}} \times \left(\sqrt{1 + \left(t_v \frac{V_{VID}}{V_V} \times \frac{nKR_O}{L} \right)^2} - 1 \right) - C_z \quad (13)$$

$$\text{where } K = 1n \left(\frac{V_{ERR}}{V_V} \right).$$

To meet the conditions of these expressions and transient response, the ESR of the bulk capacitor bank (R_x) should be less than two times the droop resistance (R_O). If the $C_{x(MIN)}$ is larger than $C_{x(MAX)}$, the system cannot meet the VID on-the-fly specification and may require the use of a smaller inductor or more phases (and may need the switching frequency to increase to keep the output ripple the same).

This example uses 18, 10 μF 1206 MLC capacitors ($C_z = 180 \mu\text{F}$). The VID on-the-fly step change is 450 mV in 230 μs with a settling error of 2.5 mV. The maximum allowable load release overshoot for this example is 50 mV, so solving for the bulk capacitance yields

$$C_{x(MIN)} \leq \left(\frac{320 \text{ nH} \times 95 \text{ A}}{4 \times \left(1.0 \text{ m}\Omega + \frac{50 \text{ mV}}{95 \text{ A}} \right) \times 1.3 \text{ V}} - 180 \mu\text{F} \right) = 3.65 \text{ mF}$$

$$C_{x(MAX)} \leq \frac{320 \text{ nH} \times 450 \text{ mV}}{4 \times 4.6^2 \times (1.0 \text{ m}\Omega)^2 \times 1.3 \text{ V}} \times$$

$$\left(\sqrt{1 + \left(\frac{230 \mu\text{s} \times 1.3 \text{ V} \times 4 \times 4.6 \times 1.0 \text{ m}\Omega}{450 \text{ mV} \times 320 \text{ nH}} \right)^2} - 1 \right) - 180 \mu\text{F} = 48.5 \text{ mF}$$

where $K = 4.6$.

Using eight 560 μF Al-Poly capacitors with a typical ESR of 5 m Ω each yields $C_x = 4.48 \text{ mF}$ with an $R_x = 0.63 \text{ m}\Omega$.

One last check should be made to ensure that the ESL of the bulk capacitors (L_x) is low enough to limit the high frequency ringing during a load change. This is tested using

$$\begin{aligned} L_x &\leq C_z \times R_O^2 \times Q^2 \\ L_x &\leq 180 \mu\text{F} \times (1 \text{ m}\Omega)^2 \times 2 = 360 \text{ pH} \end{aligned} \quad (14)$$

where Q is limited to the square root of 2 to ensure a critically damped system. In this example, L_x is approximately 350 pH for the eight A1-Polys capacitors, which satisfies this limitation. If the L_x of the chosen bulk capacitor bank is too large, the number of ceramic capacitors may need to be increased if there is excessive ringing.

For this multimode control technique, all ceramic designs can be used as long as the conditions of Equation 11, Equation 12, and Equation 13 are satisfied.

POWER MOSFETS

For this example, the N-channel power MOSFETs have been selected for one high-side switch and two low-side switches per phase. The main selection parameters for the power MOSFETs are $V_{GS(TH)}$, Q_G , C_{ISS} , C_{RSS} , and $R_{DS(ON)}$. The minimum gate drive voltage (the supply voltage to the [ADP3110A](#)) dictates whether standard threshold or logic-level threshold MOSFETs must be used. With $V_{GATE} \sim 10$ V, logic-level threshold MOSFETs ($V_{GS(TH)}^\circ < 2.5$ V) are recommended.

The maximum output current (I_O) determines the $R_{DS(ON)}$ requirement for the low-side (synchronous) MOSFETs. With the ADP3191/ADP3191A, currents are balanced between phases; thus, the current in each low-side MOSFET is the output current divided by the total number of MOSFETs (n_{SF}). With conduction losses being dominant, the following expression shows the total power being dissipated in each synchronous MOSFET in terms of the ripple current per phase (I_R) and average total output current (I_O):

$$P_{SF} = (1-D) \times \left[\left(\frac{I_O}{n_{SF}} \right)^2 + \frac{1}{12} \times \left(\frac{n I_R}{n_{SF}} \right)^2 \right] \times R_{DS(SF)} \quad (15)$$

Knowing the maximum output current being designed for and the maximum allowed power dissipation, it is possible to find the required $R_{DS(ON)}$ for the MOSFET. For D-PAK MOSFETs up to an ambient temperature of 50°C, a safe limit for P_{SF} is 1 W to 1.5 W at 120°C junction temperature. Thus, for this example (119 A maximum), $R_{DS(SF)}$ (per MOSFET) < 7.5 mΩ. This $R_{DS(SF)}$ is also at a junction temperature of about 120°C, so be certain to account for this temperature when making this selection. This example uses two lower-side MOSFETs at 4.8 mΩ each at 120°C.

Another important factor for the synchronous MOSFET is the input capacitance and feedback capacitance. The ratio of the feedback to input needs to be small (less than 10% is recommended) to prevent accidental turn-on of the synchronous MOSFETs when the switch node goes high.

Also, the time to switch the synchronous MOSFETs off should not exceed the nonoverlap dead time of the MOSFET driver (40 ns typical for the [ADP3110A](#)). The output impedance of the driver is approximately 2 Ω, and the typical MOSFET input gate resistances are about 1 Ω to 2 Ω, so a total gate capacitance of less than 6000 pF should be adhered to. Because there are two MOSFETs in parallel, the input capacitance for each synchronous MOSFET should be limited to 3000 pF.

The high-side (main) MOSFET has to be able to handle two main power dissipation components: conduction and switching losses. The switching loss is related to the amount of time it takes for the main MOSFET to turn on and off and to the current and voltage that are being switched.

Basing the switching speed on the rise and fall time of the gate driver impedance and MOSFET input capacitance, the following expression provides an approximate value for the switching loss per main MOSFET, where n_{MF} is the total number of main MOSFETs:

$$P_{S(MF)} = 2 \times f_{SW} \times \frac{V_{CC} \times I_O}{n_{MF}} \times R_G \times \frac{n_{MF}}{n} \times C_{ISS} \quad (16)$$

where R_G is the total gate resistance (2 Ω for the [ADP3110A](#) and about 1 Ω for typical high speed switching MOSFETs, making $R_G = 3$ Ω), and C_{ISS} is the input capacitance of the main MOSFET.

Adding more main MOSFETs (n_{MF}) does not really help the switching loss per MOSFET because the additional gate capacitance slows switching. The best way to reduce switching loss is to use lower gate capacitance devices.

The conduction loss of the main MOSFET is given by the following, where $R_{DS(MF)}$ is the on resistance of the MOSFET:

$$P_{C(MF)} = D \times \left[\left(\frac{I_O}{n_{MF}} \right)^2 + \frac{1}{12} \times \left(\frac{n \times I_R}{n_{MF}} \right)^2 \right] \times R_{DS(MF)} \quad (17)$$

Typically, for main MOSFETs, the highest speed (low C_{ISS}) device is preferred, but these usually have higher on resistance. Select a device that meets the total power dissipation (about 1.5 W for a single D-PAK) when combining the switching and conduction losses.

For this example, an NTD40N03L was selected as the main MOSFET (eight total; $n_{MF} = 8$), with a $C_{ISS} = 584$ pF (maximum) and $R_{DS(MF)} = 19$ mΩ (maximum at $T_J = 120^\circ\text{C}$). An NTD110N02L was selected as the synchronous MOSFET (eight total; $n_{SF} = 8$), with $C_{ISS} = 2710$ pF (maximum) and $R_{DS(SF)} = 4.8$ mΩ (maximum at $T_J = 120^\circ\text{C}$). The synchronous MOSFET C_{ISS} is less than 3000 pF, satisfying that requirement. Solving for the power dissipation per MOSFET at $I_O = 119$ A and $I_R = 11$ A yields 958 mW for each synchronous MOSFET and 872 mW for each main MOSFET. These numbers comply with the guideline to limit the power dissipation to 1 W per MOSFET.

One last thing to consider is the power dissipation in the driver for each phase. This is best described in terms of the Q_G for the MOSFETs and is given by the following equation, where Q_{GMF} is the total gate charge for each main MOSFET, and Q_{GSF} is the total gate charge for each synchronous MOSFET:

$$P_{DRV} = \left[\frac{f_{SW}}{2 \times n} \times (n_{MF} \times Q_{GMF} + n_{SF} \times Q_{GSF}) + I_{CC} \right] \times V_{CC} \quad (18)$$

Also shown is the standby dissipation factor ($I_{CC} \times V_{CC}$) for the driver. For the [ADP3110A](#), the maximum dissipation should be less than 400 mW. In this example, with $I_{CC} = 7$ mA, $Q_{GMF} = 5.8$ nC, and $Q_{GSF} = 48$ nC, 297 mW is found in each driver, which is below the 400 mW dissipation limit. See the [ADP3110A](#) data sheet for more details.

RAMP RESISTOR SELECTION

The ramp resistor (R_R) is used for setting the size of the internal PWM ramp. The value of this resistor is chosen to provide the best combination of thermal balance, stability, and transient response. The following expression is used for determining the optimum value:

$$R_R = \frac{A_R \times L}{3 \times A_D \times R_{DS} \times C_R} \quad (19)$$

$$R_R = \frac{0.2 \times 320 \text{ nH}}{3 \times 5 \times 2.4 \text{ m}\Omega \times 5 \text{ pF}} = 356 \text{ k}\Omega$$

where A_R is the internal ramp amplifier gain, A_D is the current balancing amplifier gain, R_{DS} is the total low-side MOSFET on resistance, and C_R is the internal ramp capacitor value. The closest standard 1% resistor value is 357 k Ω .

The internal ramp voltage magnitude can be calculated by using

$$V_R = \frac{A_R \times (1 - D) \times V_{VID}}{R_R \times C_R \times f_{SW}} \quad (20)$$

$$V_R = \frac{0.2 \times (1 - 0.108) \times 1.3 \text{ V}}{357 \text{ k}\Omega \times 5 \text{ pF} \times 330 \text{ kHz}} = 390 \text{ mV}$$

The size of the internal ramp can be made larger or smaller. If it is made larger, stability and transient response improve, but thermal balance degrades. Likewise, if the ramp is made smaller, thermal balance improves at the sacrifice of transient response and stability. The factor of 3 in the denominator of Equation 19 sets a ramp size that gives an optimal balance for good stability, transient response, and thermal balance.

COMP PIN RAMP

A ramp signal on the COMP pin is due to the droop voltage and output voltage ramps. This ramp amplitude adds to the internal ramp to produce the following overall ramp signal at the PWM input:

$$V_{RT} = \frac{V_R}{\left(1 - \frac{2 \times (1 - n \times D)}{n \times f_{SW} \times C_X \times R_O}\right)} \quad (21)$$

In this example, the overall ramp signal is 0.49 V.

CURRENT-LIMIT SETPOINT

To select the current-limit setpoint, first find the resistor value for R_{LIM} . The current-limit threshold for the ADP3191/ADP3191A is set with a 3 V source (V_{LIM}) across R_{LIM} with a gain of 10.4 mV/ μ A (A_{LIM}). R_{LIM} can be found using

$$R_{LIM} = \frac{A_{LIM} \times V_{LIM}}{I_{LIM} \times R_O} \quad (22)$$

For values of R_{LIM} greater than 500 k Ω , the current limit can be lower than expected, so some adjustment of R_{LIM} may be needed. Here, I_{LIM} is the average current limit for the output of the supply. In this example, choosing a peak current limit of 200 A for I_{LIM} results in $R_{LIM} = 156 \text{ k}\Omega$, for which 150 k Ω is chosen as the nearest 1% value.

The limit of the per-phase current limit described earlier is determined by

$$I_{PHLIM} \cong \frac{V_{COMP(MAX)} - V_R - V_{BIAS}}{A_D \times R_{DS(MAX)}} + \frac{I_R}{2} \quad (23)$$

For the ADP3191/ADP3191A, the maximum COMP voltage ($V_{COMP(MAX)}$) is 3.3 V, the COMP pin bias voltage (V_{BIAS}) is 1.2 V, and the current-balancing amplifier gain (A_D) is 5. Using V_R of 0.49 V and $R_{DS(MAX)}$ of 3 m Ω (low-side on resistance at 150°C), calculate a per-phase peak current limit of 100 A. Although this number may seem high, this current level can be reached only with an absolute short at the output, and the current-limit latch-off function shuts down the regulator before overheating can occur.

This limit can be adjusted by changing the ramp voltage (V_R), but make sure not to set the per-phase limit lower than the average per-phase current (I_{LIM}/n).

The per-phase initial duty cycle limit is determined by

$$D_{MAX} = D \times \frac{V_{COMP(MAX)} - V_{BIAS}}{V_{RT}} \quad (24)$$

In this example, the maximum duty cycle is 0.46.

FEEDBACK LOOP COMPENSATION DESIGN

Optimized compensation of the ADP3191/ADP3191A allows the best possible response of the regulator's output to a load change. The basis for determining the optimum compensation is to make the regulator and output decoupling appear as an output impedance that is entirely resistive over the widest possible frequency range, including dc, and equal to the droop resistance (R_O).

With the resistive output impedance, the output voltage droops in proportion to the load current at any load current slew rate. This ensures optimal positioning and allows minimization of the output decoupling.

With the multimode feedback structure of the ADP3191/ADP3191A, the feedback compensation must be set to make the converter's output impedance, working in parallel with the output decoupling, meet this goal. Several poles and zeros created by the output inductor and decoupling capacitors (output filter) need to be compensated for.

A type-three compensator on the voltage feedback is adequate for proper compensation of the output filter. Equation 25 to Equation 29 yield an optimal starting point for the design; some adjustments may be necessary to account for PCB and component parasitic effects (see the Layout and Component Placement section).

The first step is to compute the time constants for all of the poles and zeros in the system.

$$R_E = n \times R_O + A_D \times R_{DS} + \frac{R_L \times V_{RT}}{V_{VID}} + \frac{2 \times L \times (1 - n \times D) \times V_{RT}}{n \times C_X \times R_O \times V_{VID}}$$

$$R_E = 4 \times 1 \text{ m}\Omega + 5 \times 2.4 \text{ m}\Omega + \frac{1.4 \text{ m}\Omega \times 0.49 \text{ V}}{1.3 \text{ V}} + \frac{2 \times 320 \text{ nH} \times (1 - 0.432) \times 0.49 \text{ V}}{4 \times 4.45 \text{ mF} \times 1 \text{ m}\Omega \times 1.3 \text{ V}} = 24.2 \text{ m}\Omega \quad (25)$$

$$T_A = C_X \times (R_O - R') + \frac{L_X}{R_O} \times \frac{R_O - R'}{R_X} = 4.45 \text{ mF} \times (1 \text{ m}\Omega - 0.5 \text{ m}\Omega) + \frac{350 \text{ pH}}{1 \text{ m}\Omega} \times \frac{1 \text{ m}\Omega - 0.65 \text{ m}\Omega}{10.63 \text{ m}\Omega} = 2.50 \text{ }\mu\text{s} \quad (26)$$

$$T_B = (R_X + R' - R_O) \times C_X = (0.63 \text{ m}\Omega + 0.5 \text{ m}\Omega - 1 \text{ m}\Omega) \times 4.45 \text{ mF} = 580 \text{ ns} \quad (27)$$

$$T_C = \frac{V_{RT} \times \left(L - \frac{A_D \times R_{DS}}{2 \times f_{SW}} \right)}{V_{VID} \times R_E} = \frac{0.49 \text{ V} \times \left(320 \text{ nH} - \frac{5 \times 2.4 \text{ m}\Omega}{2 \times 330 \text{ kHz}} \right)}{1.3 \text{ V} \times 24.2 \text{ m}\Omega} = 4.7 \text{ }\mu\text{s} \quad (28)$$

$$T_D = \frac{C_X \times C_Z \times R_O^2}{C_X \times (R_O - R') + C_Z \times R_O} = \frac{4.45 \text{ mF} \times 180 \text{ }\mu\text{F} \times (1 \text{ m}\Omega)^2}{4.45 \text{ mF} \times (1 \text{ m}\Omega - 0.5 \text{ m}\Omega) + 180 \text{ }\mu\text{F} \times 1 \text{ m}\Omega} = 333 \text{ ns} \quad (29)$$

where, for the ADP3191/ADP3191A, R' is the PCB resistance from the bulk capacitors to the ceramics and R_{DS} is the total low-side MOSFET on resistance per phase. In this example, A_D is 5, V_{RT} equals 0.49 V, R' equals approximately 0.5 m Ω (assuming a 4-layer, 1-ounce motherboard), and L_X equals 350 pH for the eight Al-Poly capacitors.

The compensation values can then be solved using the following:

$$C_A = \frac{n \times R_O \times T_A}{R_E \times R_B} \quad (30)$$

$$C_A = \frac{4 \times 1 \text{ m}\Omega \times 2.50 \text{ }\mu\text{s}}{24.2 \text{ m}\Omega \times 1.21 \text{ k}\Omega} = 342 \text{ pF}$$

$$R_A = \frac{T_C}{C_A} = \frac{4.7 \text{ }\mu\text{s}}{342 \text{ pF}} = 13.7 \text{ k}\Omega \quad (31)$$

$$C_B = \frac{T_B}{R_B} = \frac{580 \text{ ns}}{1.21 \text{ k}\Omega} = 479 \text{ nF} \quad (32)$$

$$C_{FB} = \frac{T_D}{R_A} = \frac{333 \text{ ns}}{13.7 \text{ k}\Omega} = 24.3 \text{ pF} \quad (33)$$

These are the starting values, prior to tuning the design, to account for layout and other parasitic effects (see the Layout and Component Placement section).

The final values selected after tuning are

$$C_A = 470 \text{ pF}$$

$$R_A = 12.1 \text{ k}\Omega$$

$$C_B = 470 \text{ pF}$$

$$C_{FB} = 22 \text{ pF}$$

Figure 11 and Figure 12 show the typical transient response using these compensation values.

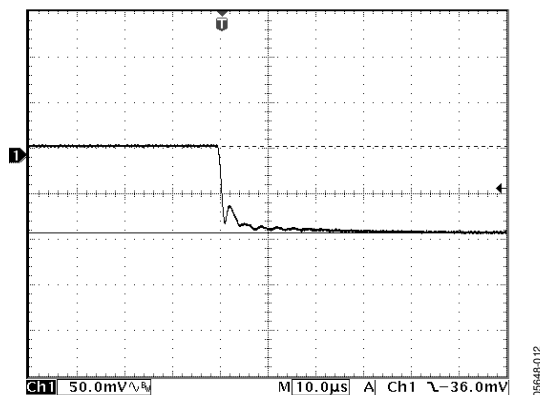

Figure 11. Typical Transient Response for Design Example Load Step

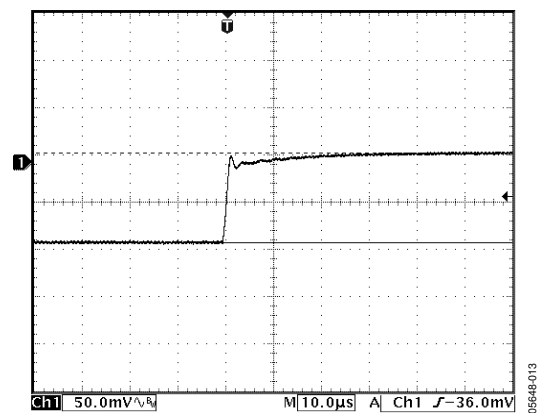

Figure 12. Typical Transient Response for Design Example Load Release

C_{IN} SELECTION AND INPUT CURRENT DI/DT REDUCTION

In continuous inductor current mode, the source current of the high-side MOSFET is approximately a square wave with a duty ratio equal to $n \times V_{OUT}/V_{IN}$ and an amplitude of one- n th the maximum output current. To prevent large voltage transients, a low ESR input capacitor, sized for the maximum rms current, must be used. The maximum rms capacitor current is given by

$$I_{CRMS} = D \times I_O \times \sqrt{\frac{1}{N \times D} - 1} \tag{34}$$

$$I_{CRMS} = 0.108 \times 119 \text{ A} \times \sqrt{\frac{1}{4 \times 0.108} - 1} = 14.7 \text{ A}$$

The capacitor manufacturer’s ripple current ratings are often based on only 2000 hours of life. This makes it advisable to further derate the capacitor or to choose a capacitor rated at a higher temperature than required. Several capacitors can be placed in parallel to meet size or height requirements in the design. In this example, the input capacitor bank is formed by two 2700 μF , 16 V aluminum electrolytic capacitors and eight 4.7 μF ceramic capacitors.

To reduce the input current di/dt to a level below the recommended maximum of 0.1 A/ μs , an additional small inductor ($L > 370 \text{ nH}$ at 18 A) should be inserted between the converter and the supply bus. This inductor also acts as a filter between the converter and the primary power source.

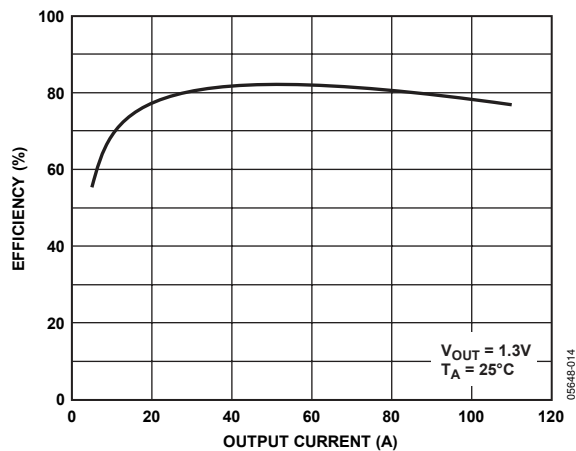

Figure 13. Efficiency of the Circuit of Figure 10 vs. Output Current

TUNING THE ADP3191/ADP3191A

1. Build a circuit based on the compensation values computed from the design spreadsheet.
2. Hook up the dc load to circuit, turn it on, and verify its operation. Also, check for jitter at no load and full load.

DC Load Line Setting

3. Measure the output voltage at no load (V_{NL}). Verify it is within tolerance.
4. Measure the output voltage at full load cold (V_{FLCOLD}). Let the board sit for ~10 minutes at full load, and then measure the output (V_{FLHOT}). If there is a change of more than a few millivolts, adjust R_{CS1} and R_{CS2} , using Equation 35 and Equation 36.

$$R_{CS2(NEW)} = R_{CS2(OLD)} \times \frac{V_{NL} - V_{FLCOLD}}{V_{NL} - V_{FLHOT}} \quad (35)$$

5. Repeat Step 4 until the cold and hot voltage measurements remain the same.

$$R_{CS1(NEW)} = \frac{1}{\frac{R_{CS1(OLD)} + R_{TH(25^{\circ}C)}}{R_{CS1(OLD)} \times R_{TH(25^{\circ}C)} + (R_{CS1(OLD)} - R_{CS2(NEW)}) \times (R_{CS1(OLD)} - R_{TH(25^{\circ}C)})} - \frac{1}{R_{TH(25^{\circ}C)}}} \quad (37)$$

6. Measure the output voltage from no load to full load, using 5 A steps. Compute the load line slope for each change, and then average to get the overall load line slope (R_{OMEAS}).
7. If R_{OMEAS} is off from R_O by more than $0.05 \text{ m}\Omega$, use the following to adjust the R_{PH} values:

$$R_{PH(NEW)} = R_{PH(OLD)} \times \frac{R_{OMEAS}}{R_O} \quad (36)$$

8. Repeat Step 6 and Step 7 to check the load line, and repeat adjustments if necessary.
9. Once dc load line adjustment is complete, do not change R_{PH} , R_{CS1} , R_{CS2} , or R_{TH} for the remainder of the procedure.
10. Measure the output ripple at no load and full load with a scope, and make sure it is within specifications.

AC Load Line Setting

- Remove the dc load from the circuit and hook up the dynamic load.
- Hook up the scope to the output voltage and set it to dc coupling, with the time scale at 100 $\mu\text{s}/\text{div}$.
- Set the dynamic load for a transient step of about 40 A at 1 kHz with a 50% duty cycle.
- Measure the output waveform (if not visible, use dc offset on scope to view). Try to use a vertical scale of 100 mV/div or finer. This waveform should look similar to Figure 14.

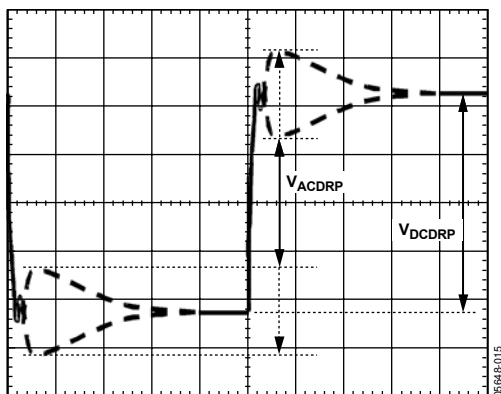

Figure 14. AC Load Line Waveform

- Use the horizontal cursors to measure V_{ACDRP} and V_{DCDRP} , as shown. Do not measure the undershoot or overshoot that happens immediately after this step.

If V_{ACDRP} and V_{DCDRP} are different by more than a few millivolts, use Equation 38 to adjust C_{CS} . It may be necessary to parallel different values to get the correct one, because there are limited standard capacitor values available. It is a good idea to have locations for two capacitors in the layout for this.

$$C_{CS(NEW)} = C_{CS(OLD)} \times \frac{V_{ACDRP}}{V_{DCDRP}} \quad (38)$$

- Repeat Step 11 to Step 13, and repeat the adjustments, if necessary. Once complete, do not change C_{CS} for the remainder of the procedure.
- Set the dynamic load step to maximum step size. Do not use a step size larger than needed, and verify that the output waveform is square, which means that V_{ACDRP} and V_{DCDRP} are equal.

Initial Transient Setting

- With the dynamic load still set at the maximum step size, expand the scope time scale to see 2 $\mu\text{s}/\text{div}$ to 5 $\mu\text{s}/\text{div}$. The waveform may have two overshoots and one minor undershoot (see Figure 15). Here, V_{DROOP} is the final desired value.

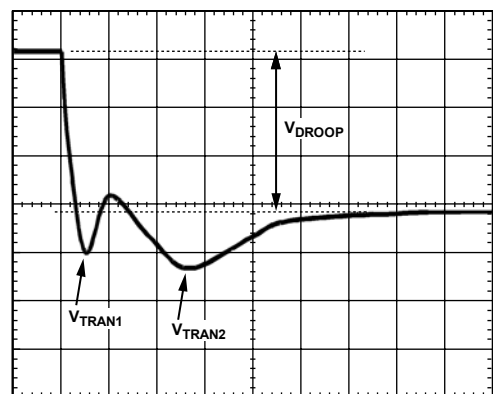

Figure 15. Transient Setting Waveform

- If both overshoots are larger than desired, try making the following adjustments:
 - Make the ramp resistor larger by 25% (R_{RAMP}).
 - For V_{TRAN1} , increase C_B , or increase the switching frequency.
 - For V_{TRAN2} , increase R_A , and decrease C_A by 25%.

If these adjustments do not change the response, the output decoupling is the limiting factor. Check the output response every time a change is made, or nodes are switched, to make sure the response remains stable.

- For load release (see Figure 16), if $V_{TRANREL}$ is larger than V_{TRAN1} (see Figure 15), there is not enough output capacitance. Either more capacitance is needed or the inductor values need to be smaller. If inductors are changed, start the design again using the spreadsheet and this tuning procedure.

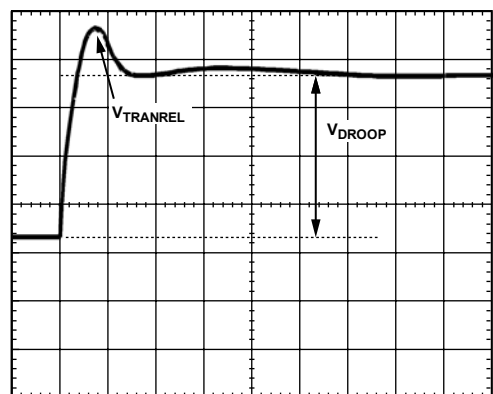

Figure 16. Transient Setting Waveform

SHUNT RESISTOR DESIGN

When replacing an existing ADP3181 design with the ADP3191, the shunt resistor value needs to be determined. A trade-off can be made between the power dissipated in the shunt resistor and the UVLO threshold. Figure 19 shows the typical resistor value needed to realize certain UVLO voltages. It also gives the maximum power dissipated in the shunt resistor for these UVLO voltages. The maximum power dissipated is calculated using Equation 39.

$$P_{MAX} = \frac{(V_{IN(MAX)} - V_{CC(MIN)})^2}{R_{SHUNT}} \quad (39)$$

where:

$V_{IN(MAX)}$ is the maximum voltage from the 12 V input supply. (If the 12 V input supply is 12 V \pm 5%, then $V_{IN(MAX)} = 12.6$ V. If the 12 V input supply is 12 V \pm 10%, then $V_{IN(MAX)} = 13.2$ V.) The graph shows the power when $V_{IN(MAX)} = 12.6$ V.

$V_{CC(MIN)}$ is the minimum V_{CC} voltage of the ADP3191. It is specified as 4.75 V.

R_{SHUNT} is the shunt resistor value.

The CECC standard specification for power rating in surface mount resistors is 0603 = 0.1 W, 0805 = 0.125 W, 1206 = 0.25 W.

Example: UVLO voltage specification = 8 V.

From Figure 19, a shunt resistor value of 420 Ω is recommended. From Figure 19, the power dissipation will be 140 mW. The user can choose any of the following:

- Two 840 Ω , 0603 resistors in parallel
- Two 840 Ω , 0805 resistors in parallel
- One 420 Ω , 1206 resistor

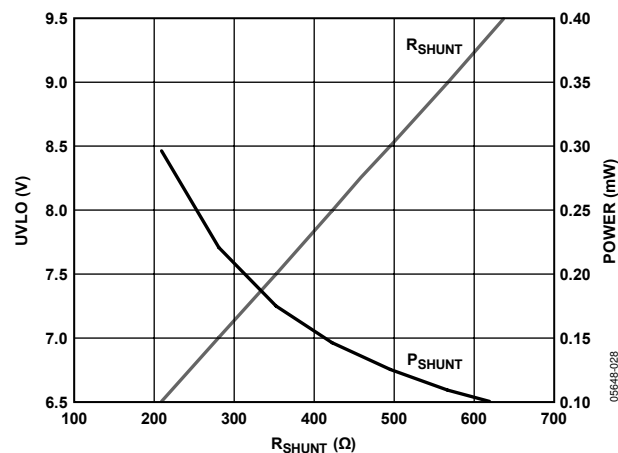

Figure 19. Typical Shunt Resistor Value and Power Dissipation for Different UVLO Voltages

LAYOUT AND COMPONENT PLACEMENT

The following guidelines are recommended for optimal performance of a switching regulator in a PC system.

GENERAL RECOMMENDATIONS

- For good results, a PCB with at least four layers is recommended. This allows the needed versatility for control circuitry interconnections with optimal placement; power planes for ground, input, and output power; and wide interconnection traces in the remainder of the power delivery current paths.

Note: Each square unit of 1 ounce copper trace has a resistance of ~ 0.53 m Ω at room temperature.

- Whenever high currents must be routed between PCB layers, vias should be used liberally to create several parallel current paths. Then, the resistance and inductance introduced by these current paths is minimized, and the via current rating is not exceeded.
- If critical signal lines, including the output voltage sense lines of the ADP3191/ADP3191A, must cross through power circuitry, it is best if a signal ground plane can be interposed between those signal lines and the traces of the power circuitry. This serves as a shield to minimize noise injection into the signals at the expense of making signal ground noisier.
- Use an analog ground plane around and under the ADP3191/ADP3191A as a reference for the components associated with the controller. This plane should be tied to the nearest output decoupling capacitor ground and not tied to any other power circuitry. This prevents power currents from flowing in the ground plane.
- Locate the components around the ADP3191/ADP3191A close to the controller with short traces. The most important traces to keep short, and away from other traces, are the FB pin and the CSSUM pin. Connect the output capacitors as close as possible to the load (or connector), for example, a microprocessor core that receives the power. If the load is distributed, the capacitors should also be distributed and generally be in proportion to where the load tends to be more dynamic.
- Avoid crossing any signal lines over the switching power path loop, as described in the Power Circuitry Recommendations section.

POWER CIRCUITRY RECOMMENDATIONS

- The switching power path should be routed on the PCB to encompass the shortest possible length to minimize radiated switching noise energy (that is, EMI) and conduction losses in the board. Failure to take proper precautions often results in EMI problems for the entire PC system as well as noise-related operational problems in the power converter control circuitry. The switching power path is the loop formed by the current path through the input capacitors and the power MOSFETs, including all interconnecting PCB traces and planes. Using short and wide interconnection traces is especially critical in this path for two reasons: it minimizes the inductance in the switching loop, which can cause high energy ringing; and it accommodates the high current demand with minimal voltage loss.
- Whenever a power dissipating component, (for example, a power MOSFET), is soldered to a PCB, the liberal use of vias, both directly on the mounting pad and immediately surrounding it, is recommended. This improves current rating through the vias and also improves thermal performance from vias extended to the opposite side of the PCB, where a plane can more readily transfer the heat to the air. Make a mirror image of any pad being used to heat-sink the MOSFETs on the opposite side of the PCB to achieve the best thermal dissipation to the air around the board. To further improve thermal performance, use the largest possible pad area.
- The output power path should also be routed to encompass a short distance. The output power path is formed by the current path through the inductor, the output capacitors, and the load.
- For best EMI containment, a solid power ground plane should be used as one of the inner layers extending fully under all the power components.

SIGNAL CIRCUITRY RECOMMENDATIONS

- The output voltage is sensed and regulated between the FB pin and the FBRTN pin, which connect to the signal ground at the load. To avoid differential-mode noise pickup in the sensed signal, the loop area should be small. Thus, the FB and FBRTN traces should be routed adjacent to each other on top of the power ground plane back to the controller.
- The feedback traces from the switch nodes should be connected as close as possible to the inductor. The CSREF signal should be connected to the output voltage at the nearest inductor to the controller.

OUTLINE DIMENSIONS

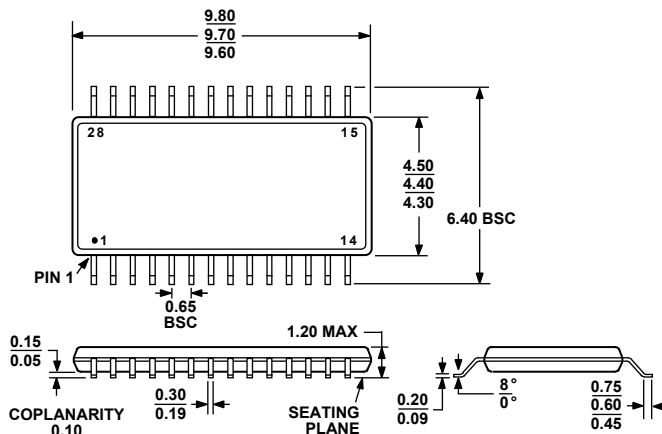

COMPLIANT TO JEDEC STANDARDS MO-153-AE

Figure 20. 28-Lead Thin Shrink Small Outline Package [TSSOP] (RU-28)

Dimensions shown in millimeters

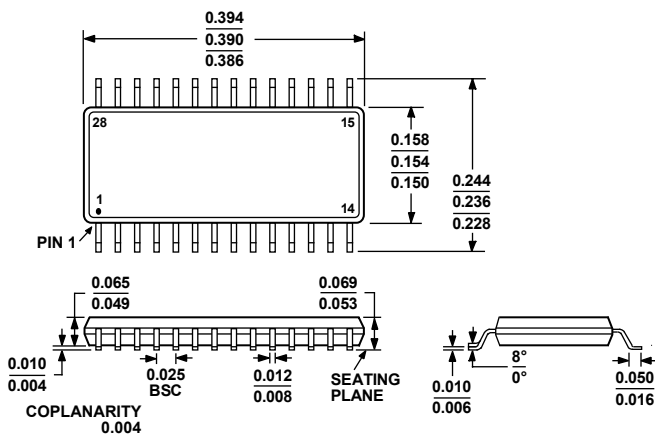

COMPLIANT TO JEDEC STANDARDS MO-137-AF

Figure 21. 28-Lead Shrink Small Outline Package [QSOP] (RQ-28)

Dimensions shown in inches

ORDERING GUIDE

Model	Temperature Range	Package Description	Package Option	Ordering Quantity
ADP3191JRUZ-RL ¹	0°C to 85°C	28-Lead TSSOP 13" Reel	RU-28	2500
ADP3191JRQZ-RL ¹	0°C to 85°C	28-Lead QSOP 13" Reel	RQ-28	2500
ADP3191AJRUZ-RL ¹	0°C to 85°C	28-Lead TSSOP 13" Reel	RU-28	2500
ADP3191AJRQZ-RL ¹	0°C to 85°C	28-Lead QSOP 13" Reel	RQ-28	2500

¹ Z = Pb-free part.

ADP3191

NOTES