

International  
**IOR** Rectifier

**SAFEIR** Series  
10ETS..FPPbF

**INPUT RECTIFIER DIODE  
TO-220 FULLPAK  
Lead-Free ("PbF" suffix)**

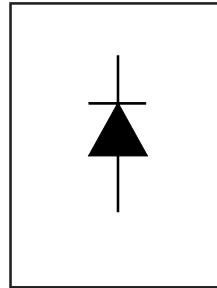

$$V_F < 1.1V @ 10A$$

$$I_{FSM} = 200A$$

$$V_{RRM} = 800-1200V$$

**Description/ Features**

The 10ETS12FPPbF rectifier **SAFEIR** series has been optimized for very low forward voltage drop, with moderate leakage. The glass passivation technology used has reliable operation up to 150°C junction temperature.

Typical applications are in input rectification and these products are designed to be used with International Rectifier Switches and Output Rectifiers which are available in identical package outlines. Fully isolated package ( $V_{INS} = 2500 V_{RMS}$ ).

UL E78996 approved 

**Output Current in Typical Applications**

Applications	Single-phase Bridge	Three-phase Bridge	Units
Capacitive input filter $T_A = 55^\circ C, T_J = 125^\circ C$ common heatsink of $1^\circ C/W$	12.0	16.0	A

**Major Ratings and Characteristics**

Characteristics	Values	Units
$I_{F(AV)}$ Sinusoidal waveform	10	A
$V_{RRM}$ Range	800-1200	V
$I_{FSM}$	200	A
$V_F$ @10A, $T_J = 25^\circ C$	1.1	V
$T_J$	-40to150	$^\circ C$

**Package Outline**

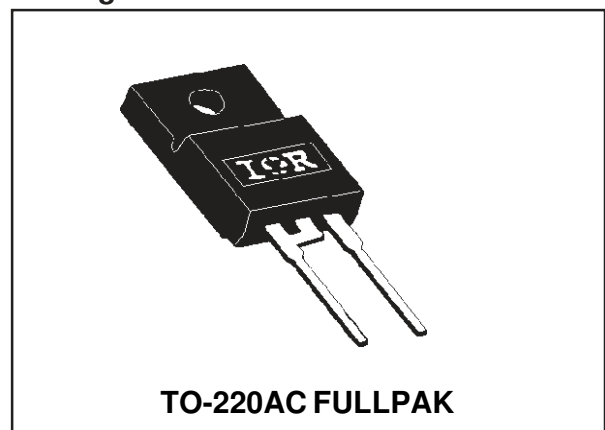

### Voltage Ratings

Part Number	$V_{RRM}$ , maximum peak reverse voltage V	$V_{RSM}$ , maximum non repetitive peak reverse voltage V	$I_{RRM}$ 150°C mA
10ETS12FPPbF	1200	1300	0.5
10ETS08FPPbF	800	900	0.5

### Absolute Maximum Ratings

Parameters	Values	Units	Conditions
$I_{F(AV)}$ Max. Average Forward Current	10	A	@ $T_C = 105^\circ\text{C}$ , 180° conduction half sine wave
$I_{FSM}$ Max. Peak One Cycle Non-Repetitive Surge Current	170	A	10ms Sine pulse, rated $V_{RRM}$ applied
	200		10ms Sine pulse, no voltage reapplied
$I^2t$ Max. $I^2t$ for fusing	130	$A^2s$	10ms Sine pulse, rated $V_{RRM}$ applied
	145		10ms Sine pulse, no voltage reapplied
$I^2\sqrt{t}$ Max. $I^2\sqrt{t}$ for fusing	1450	$A^2\sqrt{s}$	t = 0.1 to 10ms, no voltage reapplied

### Electrical Specifications

Parameters	Values	Units	Conditions
$V_{FM}$ Max. Forward Voltage Drop	1.1	V	@ 10A, $T_J = 25^\circ\text{C}$
$r_t$ Forward slope resistance	20	$m\Omega$	$T_J = 150^\circ\text{C}$
$V_{F(TO)}$ Threshold voltage	0.82	V	
$I_{RM}$ Max. Reverse Leakage Current	0.05	mA	$T_J = 25^\circ\text{C}$
	0.50		$T_J = 150^\circ\text{C}$

$V_R = \text{rated } V_{RRM}$

### Thermal-Mechanical Specifications

Parameters	Values	Units	Conditions
$T_J$ Max. Junction Temperature Range	-40 to 150	$^\circ\text{C}$	
$T_{stg}$ Max. Storage Temperature Range	-40 to 150	$^\circ\text{C}$	
$R_{thJC}$ Max. Thermal Resistance Junction to Case	2.5	$^\circ\text{C/W}$	DC operation
$R_{thJA}$ Max. Thermal Resistance Junction to Ambient	62	$^\circ\text{C/W}$	
$R_{thCS}$ Typical Thermal Resistance, Case to Heatsink	0.5	$^\circ\text{C/W}$	Mounting surface, smooth and greased
wt Approximate Weight	2 (0.07)	g (oz.)	
T Mounting Torque	Min.	6 (5)	$\text{Kg-cm}$ (lbf-in)
	Max.	12 (10)	
Case Style	TO-220 FULLPAK		(94/V0)

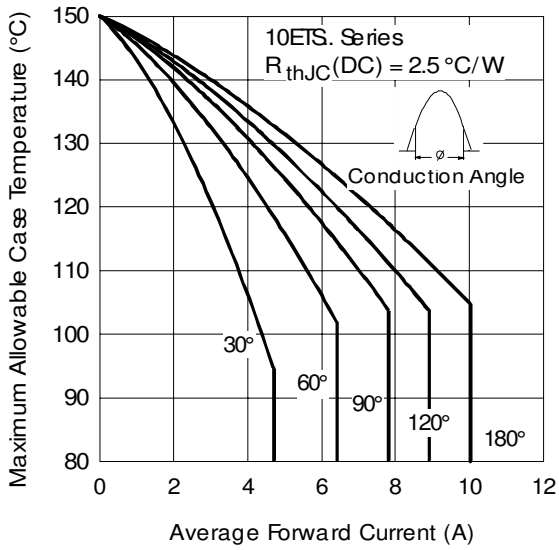

Fig. 1 - Current Rating Characteristics

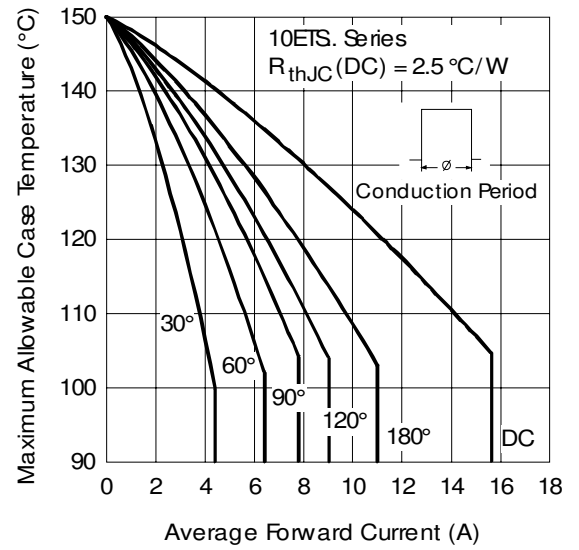

Fig. 2 - Current Rating Characteristics

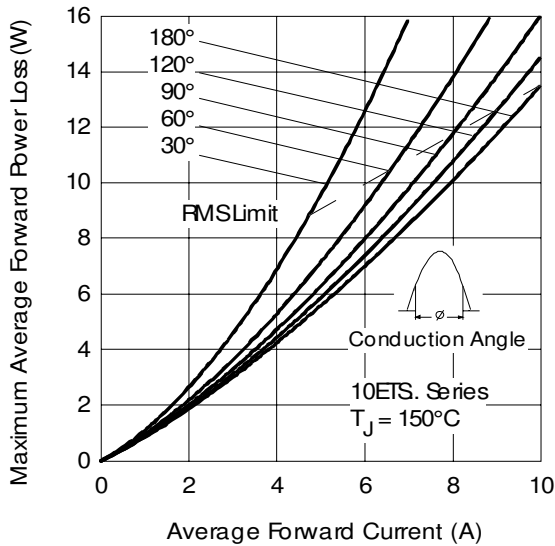

Fig. 3 - Forward Power Loss Characteristics

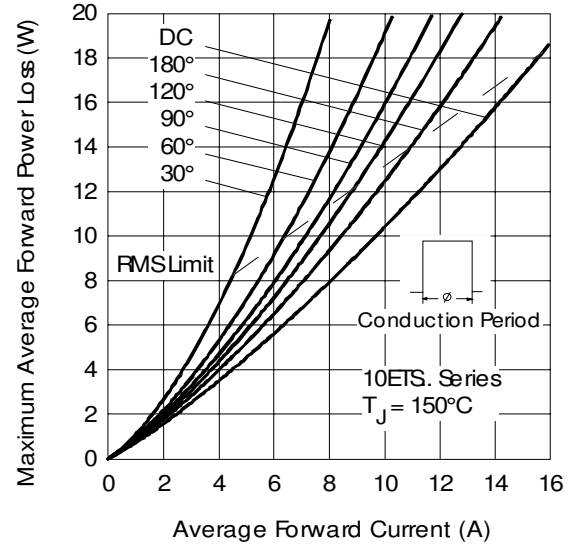

Fig. 4 - Forward Power Loss Characteristics

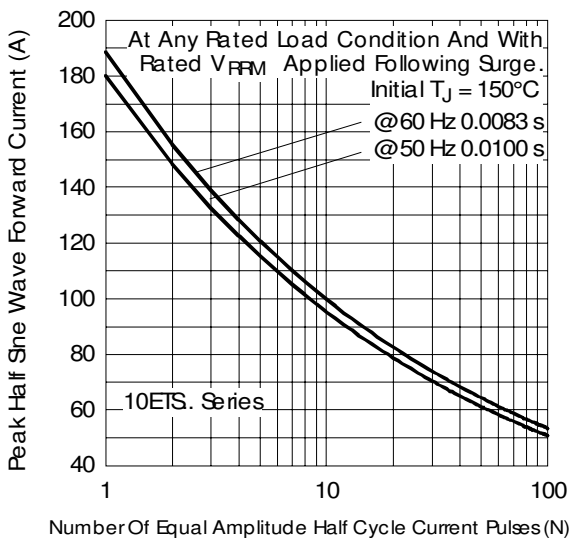

Fig. 5 - Maximum Non-Repetitive Surge Current

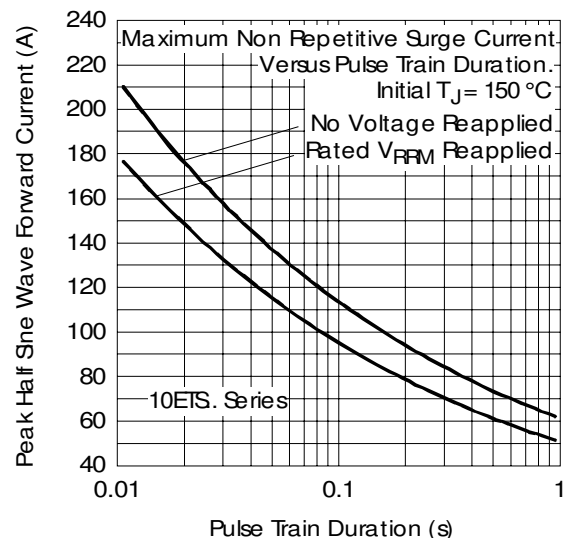

Fig. 6 - Maximum Non-Repetitive Surge Current

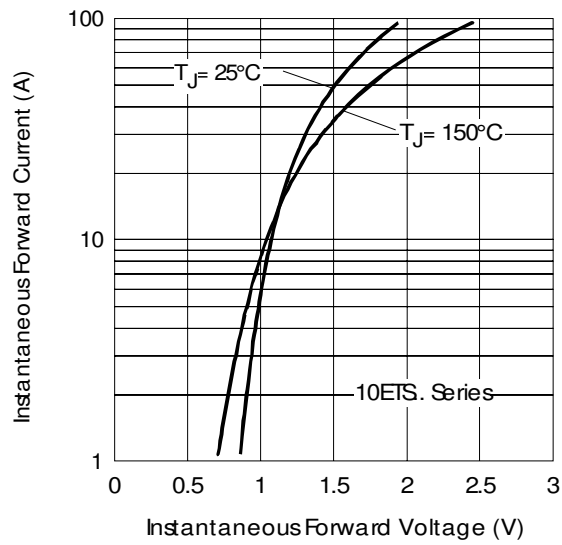

Fig. 8 - Forward Voltage Drop Characteristics

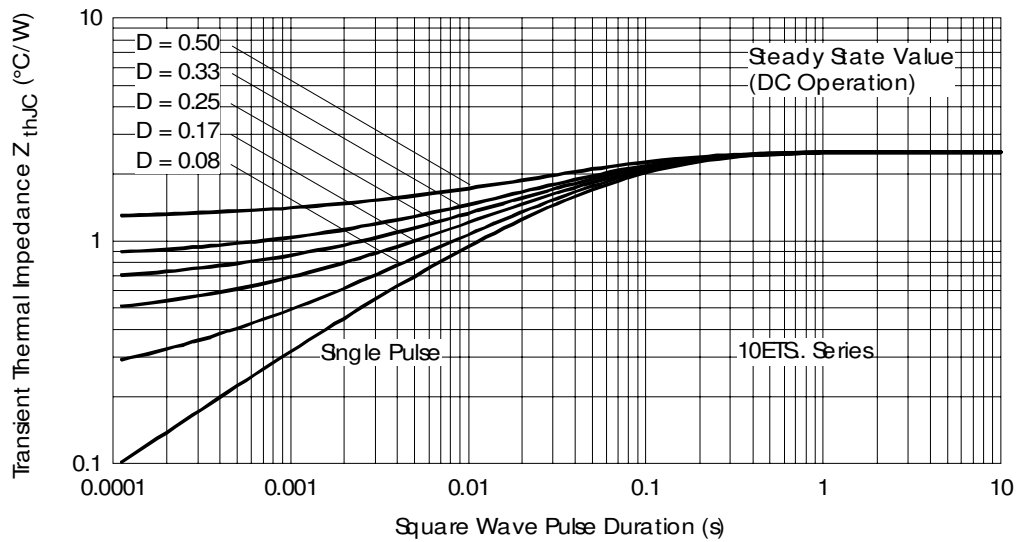
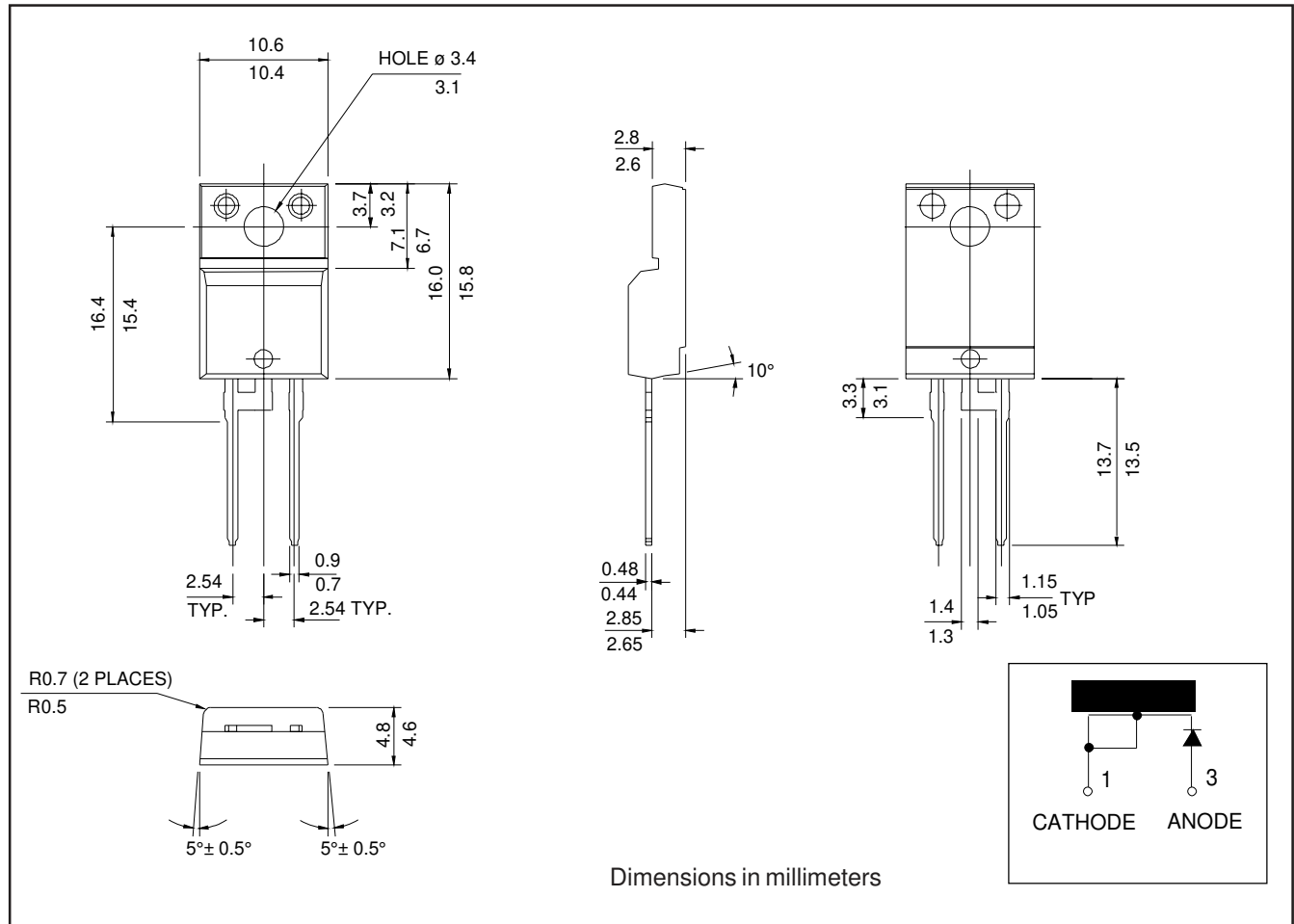
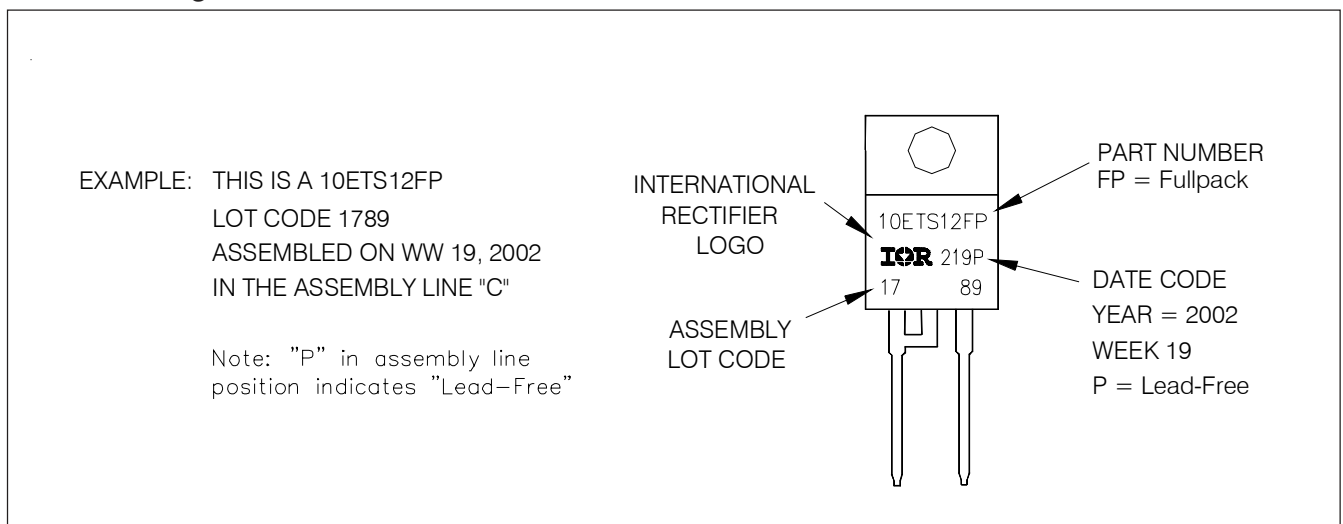

Fig. 9 - Thermal Impedance  $Z_{thJC}$  Characteristics

Outline Table



Part Marking Information



Ordering Information Table

Device Code						
1	2	3	4	5	6	7
10	E	T	S	12	FP	PbF
1	-	Current Rating (10 = 10A)				
2	-	Circuit Configuration:				
		E = Single Diode				
3	-	Package:				
		T = TO-220AC				
4	-	Type of Silicon:				
		S = Standard Recovery Rectifier				
5	-	Voltage Rating				
		12 = 1200V				
		08 = 800V				
6	-	Fullpak				
7	-	• none = Standard Production				
		• PbF = Lead-Free				

Data and specifications subject to change without notice.  
This product has been designed and qualified for Industrial Level and Lead-Free.  
Qualification Standards can be found on IR's Web site.



## Notice

The products described herein were acquired by Vishay Intertechnology, Inc., as part of its acquisition of International Rectifier's Power Control Systems (PCS) business, which closed in April 2007. Specifications of the products displayed herein are pending review by Vishay and are subject to the terms and conditions shown below.

Specifications of the products displayed herein are subject to change without notice. Vishay Intertechnology, Inc., or anyone on its behalf, assumes no responsibility or liability for any errors or inaccuracies.

Information contained herein is intended to provide a product description only. No license, express or implied, by estoppel or otherwise, to any intellectual property rights is granted by this document. Except as provided in Vishay's terms and conditions of sale for such products, Vishay assumes no liability whatsoever, and disclaims any express or implied warranty, relating to sale and/or use of Vishay products including liability or warranties relating to fitness for a particular purpose, merchantability, or infringement of any patent, copyright, or other intellectual property right.

The products shown herein are not designed for use in medical, life-saving, or life-sustaining applications. Customers using or selling these products for use in such applications do so at their own risk and agree to fully indemnify Vishay for any damages resulting from such improper use or sale.

International Rectifier®, IR®, the IR logo, HEXFET®, HEXSense®, HEXDIP®, DOL®, INTERO®, and POWIRTRAIN® are registered trademarks of International Rectifier Corporation in the U.S. and other countries. All other product names noted herein may be trademarks of their respective owners.