

Figure 1

1. INTRODUCTION

Extraction Tool 2161614-1 (Figure 1) is designed to remove DATA DART pin and socket kits (assemblies) from GbE and Power Modules.

Each of the DATA DART kits (assemblies) contains a housing and either pins or socket contacts.

Read these instructions thoroughly before attempting to remove any contacts.

NOTE



All dimensions are in millimeters [followed by inches in brackets]. Figures and illustrations are for reference only, and are not drawn to scale.

2. DESCRIPTION

The tool features a handle and a release tip. Refer to Figure 1. The tip is designed to slide along the top and bottom of the DATA DART pin or socket assemblies, down into the module and release the retention clips inside the module, allowing you to grip the wires and pull out the terminated assembly.

The tool features a handle marked with the part number and a release tip. Refer to Figure 1.

3. USING THE TOOL

NOTE



Figures on this instruction sheet illustrate the socket DATA DART assemblies. The function of the tool is the same for pins and sockets used with DATA DART assemblies

1. Wipe the tool and be sure that there is no dirt or foreign particles on the tool.
2. Position the wires and cables so that the tool can be positioned as shown in Figure 2 and Figure 3 without causing unwanted interference between the tool and the wires.

NOTE



Cables are NOT shown for purposes of clarity.

3. Gently slide the tines of the tool along the top and bottom of the DATA DART assemblies as shown in Figure 2 and Figure 3. The contour of the tool matches the contour of the assembly.

4. When the tool bottoms in the housing the retention tines will spring out of the way of the contact. (Refer to Figure 3).

5. Pull the wires and the tool at the same time. This should pull the contact past the retention clips and allow it to be pulled out of the module.

4. MAINTENANCE AND INSPECTION

It is recommended that each tool be inspected upon arrival to be sure it has not been damaged in transit. It should also be inspected at regularly scheduled intervals to be sure it remains functional.

Be sure to keep the tool clean. Keep the tool lightly oiled when not in use.

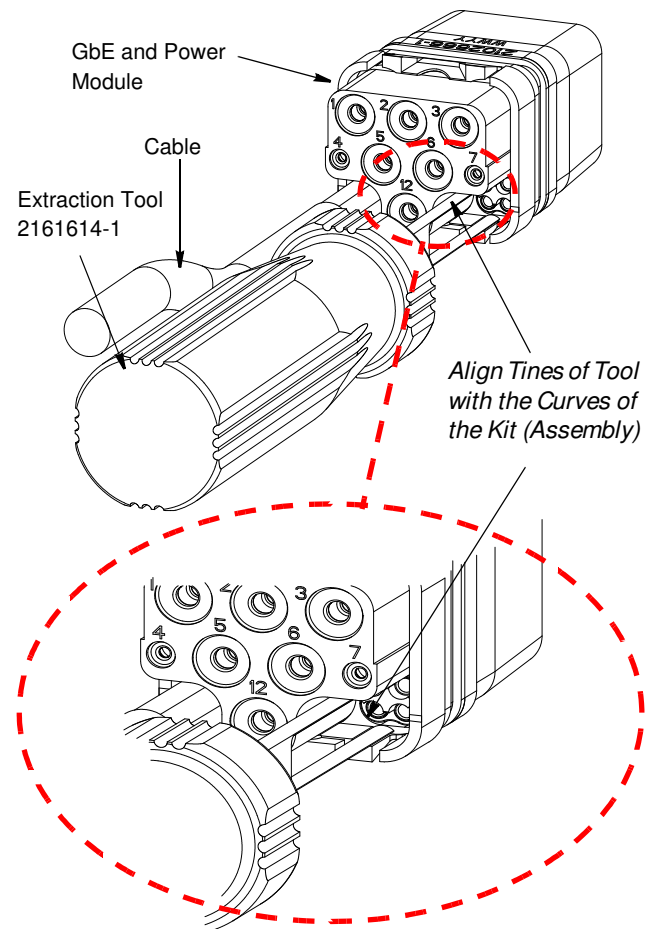

Figure 2

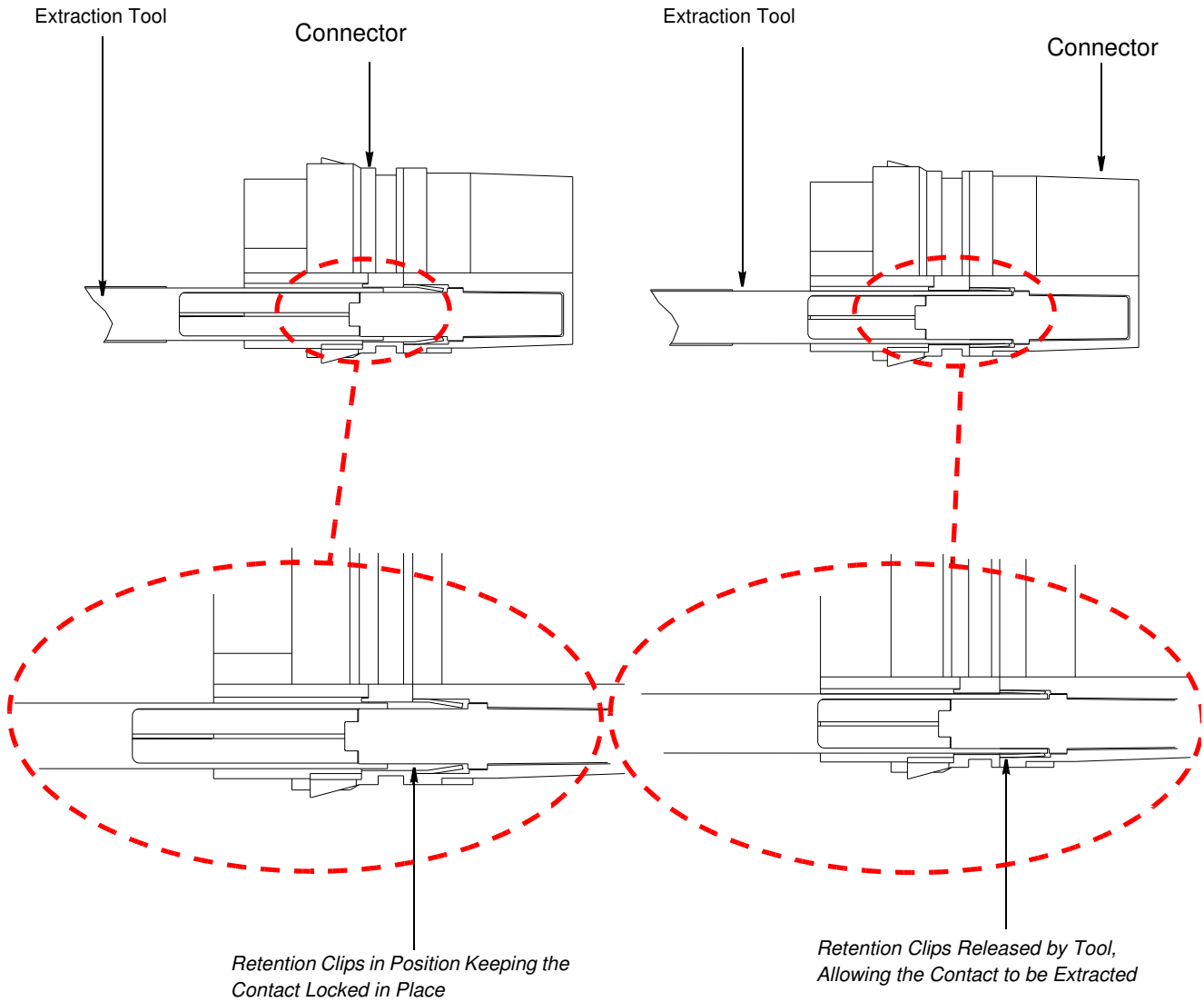

Figure 3

5. REVISION SUMMARY

New release of 408-32066