

SD 35725-4810

ENG. NO

EDP NO.

SIMILAR ITEM

PROJECT NO.

8

7

6

5

4

3

2

1

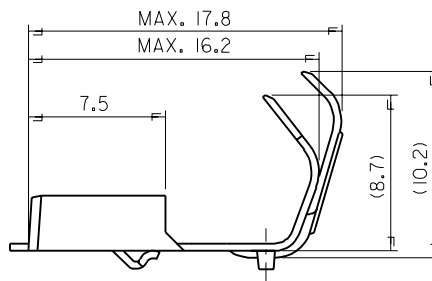
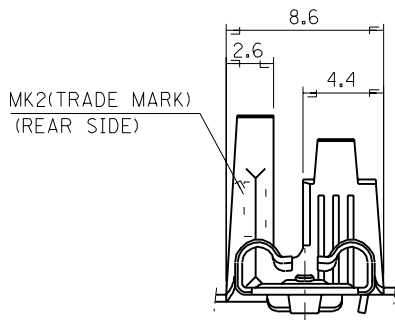
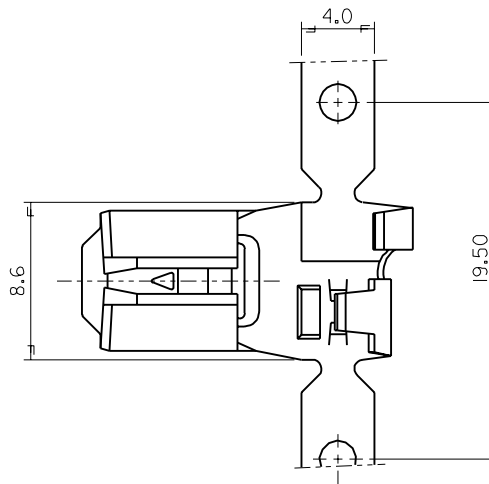
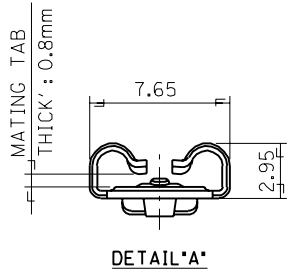

NOTES

1. MATERIAL : BRASS, 0.4mm Thk'
2. FINISH : PRE-TIN PLATING
3. MATING TAB THICKNESS : 0.8mm
4. APPLICABLE HOUSING: 35165-010*

WIRE RANGE AWG #18-#14				MATERIAL SEE NOTES		MOLEX-KOREA CO.,LTD.	
INSULATION RANGE 2.8-3.8mm DIA.				GENERAL TOLERANCE DIMENSION : +0.3		DRAWN BY W.Y.YANG	CHK'D BY
DIE FEED: ---		A	NEW RELEASED	95-012	95.125	APP'D BY	SCALE 4:1
APPLICATOR FEED: 19.5		LTR	REVISION RECORD	ECN	DATE	TITLE: .250 SAFE LOCK	
Q'TY/ REEL OR PACK 3,000 Q'ty/Reel		REVISE ONLY ON CAD SYSTEM				ASS'Y PART DESCRIPTION/ ENG. NO.	
						SHEET 10F1	
						ENG. NO. SD 35725-4810	
						REV A	