

ITEM	QTY	PART NUMBER	PART DESCRIPTION
1	1	H-485C	Quad-Level Sub-Miniature (1.8mm) LED 90° Holder
2	4	1.8HD	Small Footprint, Radial Lead Orientation (1.8mm)

REV.	DESCRIPTION	DATE	APPROVED
A	Engineering Release	05/24/06	M. C.
B	Engineering Update w/o Changes	08/05/16	J. C.

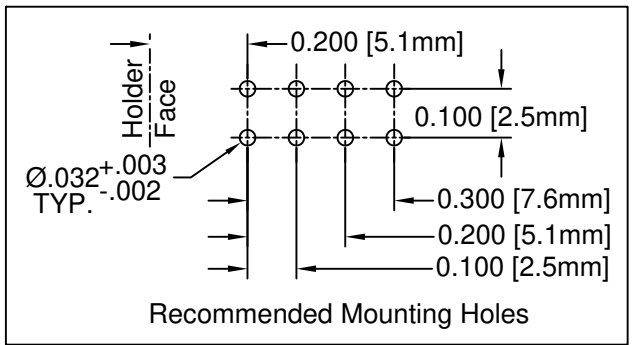
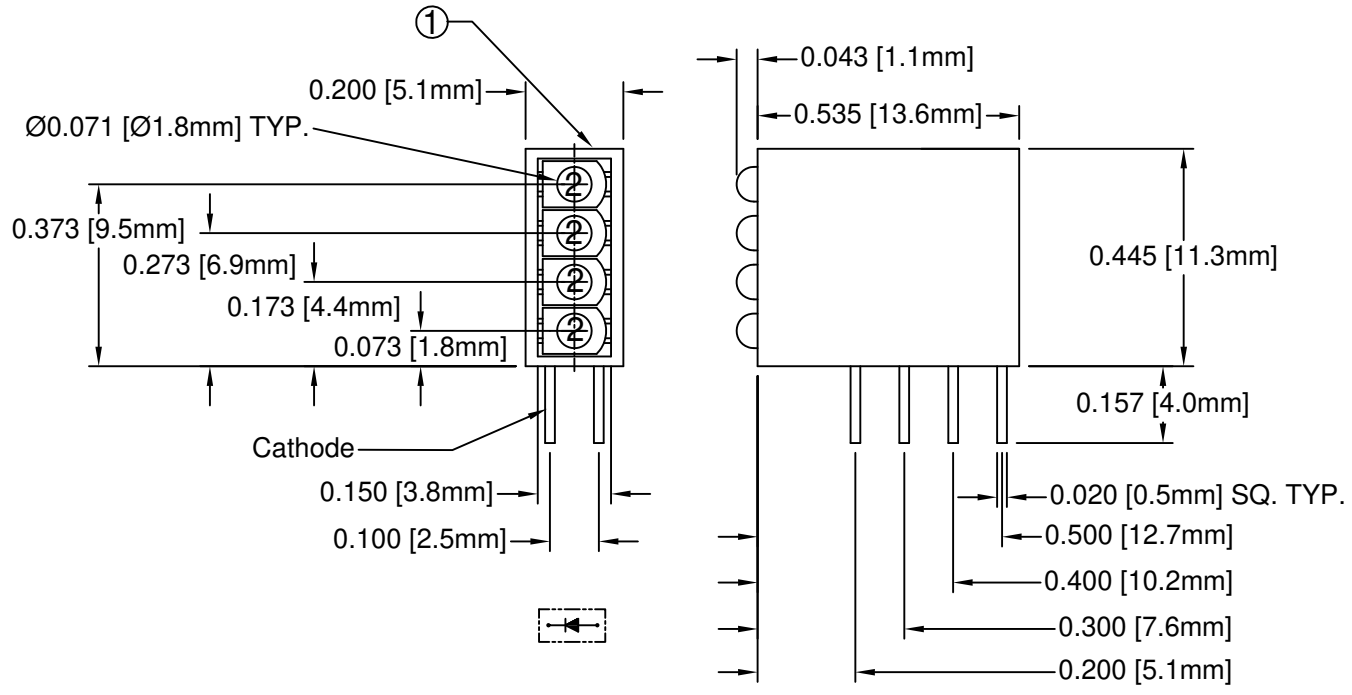

LED Part No.	Chip			Lens Appearance	Absolute Max. Ratings				Electro-Optical Data @ 20mA			Viewing Angle (Deg)
	Material	Peak Wave Length λ_p (nm)	Emitted Color		$\Delta\lambda$ (nm)	Pd (mW)	If (mA)	Peak If (mA)	Vf (V)		Iv (mcd)	
									TYP	MAX	TYP	
1.8HD	GaAsP/GaP	635	HE RED	45	80	30	150	2.0	2.6	5.0	70	

ABSOLUTE MAXIMUM RATINGS (Ta = 25°C)

- REVERSE VOLTAGE _____ 5V
- REVERSE CURRENT (VR=5V) _____ 100µA
- OPERATING TEMPERATURE RANGE _____ -25°C ~ 85°C
- STORAGE TEMPERATURE _____ -30°C ~ 100°C
- LEAD SOLDERING TEMPERATURE (1/16" FROM BODY) _____ 260°C for 5 Seconds

STANDARD TOLERANCE (UNLESS OTHERWISE SPECIFIED)		 4 THOMAS, IRVINE, CA. 92618 TEL: (949) 951-8808 FAX: (949) 951-3974	
DECIMALS	ANGULAR		
.X ±.1	X° ± 1°		
.XX ±.02			TITLE: Sub-Miniature (1.8mm) RP 90° Quad-Level LED Assembly
.XXX ±.010			PART NO: H485CHD-RP
DESIGNED: S. Dam	DATE: 05/24/06	REVISION: B	CAGE CODE : 32559 SHEET # 1 OF 1
CHECKED: T. Yin	DATE: 05/24/06	CAD GENERATED DOCUMENT. DO NOT MEASURE DRAWING.	