

# CS8361

## LDO Linear Voltage Regulator - Dual Micropower, Tracking, Reset, Enable

**250 mA, 100 mA, 5.0 V**

The CS8361 is a precision Micropower dual voltage regulator with  $\overline{\text{ENABLE}}$  and  $\overline{\text{RESET}}$ .

The 5.0 V standby output is accurate within  $\pm 2\%$  while supplying loads of 100 mA and has a typical dropout voltage of 400 mV. Quiescent current is low, typically 140  $\mu\text{A}$  with a 300  $\mu\text{A}$  load. The active  $\overline{\text{RESET}}$  output monitors the 5.0 V standby output and is low during power-up and regulator dropout conditions. The  $\overline{\text{RESET}}$  circuit includes hysteresis and is guaranteed to operate correctly with 1.0 V on the standby output.

The second output tracks the 5.0 V standby output through an external adjust lead, and can supply loads of 250 mA with a typical dropout voltage of 400 mV. The logic level  $\overline{\text{ENABLE}}$  lead is used to control this tracking regulator output.

Both outputs are protected against overvoltage, short circuit, reverse battery and overtemperature conditions. The robustness and low quiescent current of the CS8361 makes it not only well suited for automotive microprocessor applications, but for any battery powered microprocessor applications.

### Features

- 2 Regulated Outputs
  - Standby Output 5.0 V  $\pm 2\%$ ; 100 mA
  - Tracking Output 5.0 V; 250 mA
- Low Dropout Voltage (0.4 V at Rated Current)
- RESET Option
- ENABLE Option
- Low Quiescent Current
- Protection Features
  - Independent Thermal Shutdown
  - Short Circuit
  - 60 V Load Dump
  - Reverse Battery
- Internally Fused Leads in SO-16L Package
- These are Pb-Free Devices



ON Semiconductor®

<http://onsemi.com>

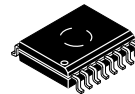

SO-16L  
DW SUFFIX  
CASE 751G

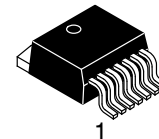

D<sup>2</sup>PAK-7  
DPS SUFFIX  
CASE 936AB

### PIN CONNECTIONS AND MARKING DIAGRAM

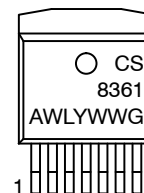
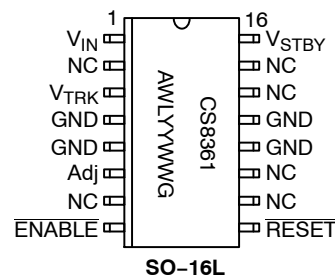

- Pin 1. V<sub>STBY</sub>  
2. V<sub>IN</sub>  
3. V<sub>TRK</sub>  
4. GND  
5. Adj  
6. ENABLE  
7. RESET

### D<sup>2</sup>PAK-7

CS8361 = Device Code  
A = Assembly Location  
WL = Wafer Lot  
YY = Year  
WW = Work Week  
G = Pb-Free Package

### ORDERING INFORMATION

See detailed ordering and shipping information in the package dimensions section on page 6 of this data sheet.

\*For additional information on our Pb-Free strategy and soldering details, please download the ON Semiconductor Soldering and Mounting Techniques Reference Manual, SOLDERRM/D.

# CS8361

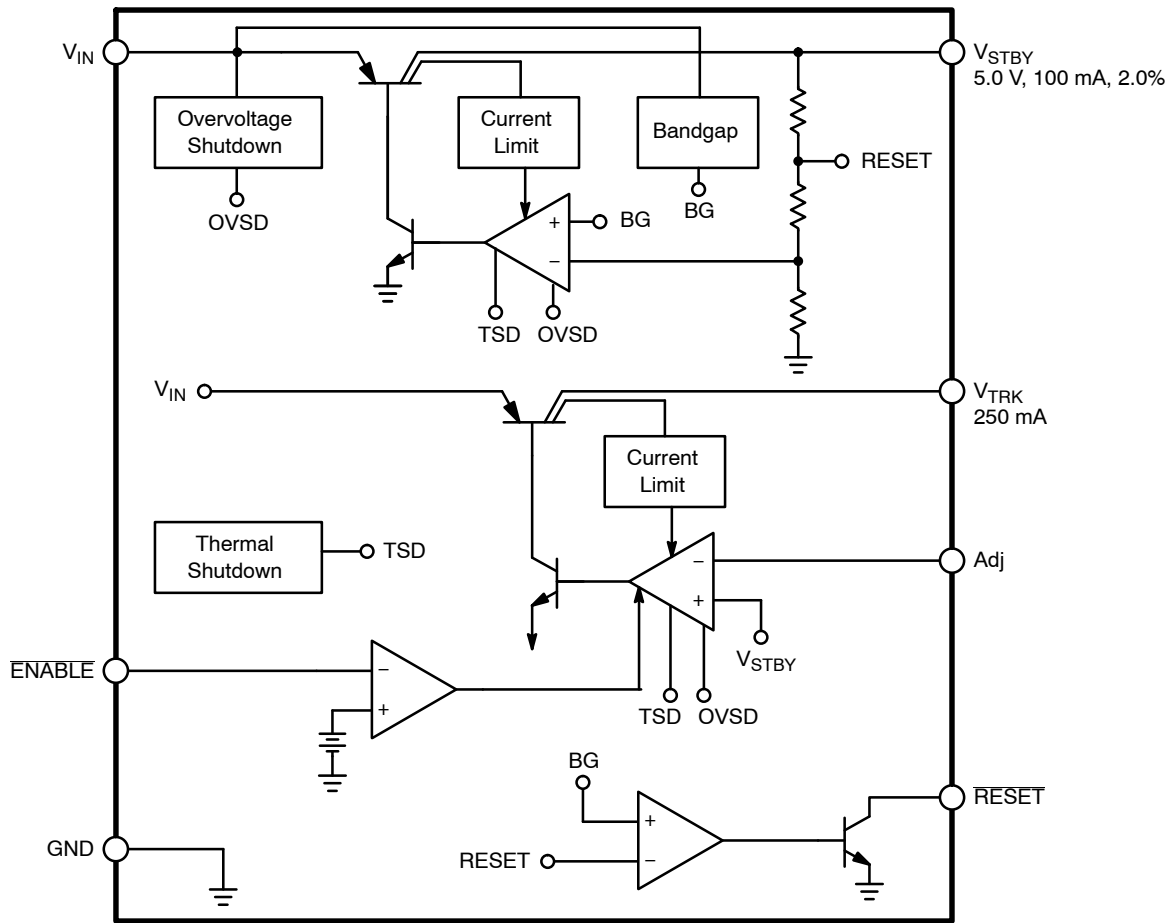

Figure 1. Block Diagram. Consult Your Local Sales Representative for Positive ENABLE Option

## MAXIMUM RATINGS\*

Rating	Value	Unit	
Supply Voltage, $V_{IN}$	-16 to 26	V	
Positive Transient Input Voltage, $t_r > 1.0$ ms	60	V	
Negative Transient Input Voltage, $T < 100$ ms, 1.0 % Duty Cycle	-50	V	
Input Voltage Range ( $\overline{ENABLE}$ , $\overline{RESET}$ )	-0.3 to 10	V	
Tracking Regulator ( $V_{TRK}$ , Adj)	20	V	
Standby Regulator ( $V_{STBY}$ )	10	V	
Junction Temperature	-40 to +150	°C	
Storage Temperature Range	-55 to +150	°C	
ESD Susceptibility (Human Body Model)	2.0	kV	
Lead Temperature Soldering	Wave Solder (through hole styles only) Note 1 Reflow (SMD styles only) Note 2	260 peak 230 peak	°C °C

Maximum ratings are those values beyond which device damage can occur. Maximum ratings applied to the device are individual stress limit values (not normal operating conditions) and are not valid simultaneously. If these limits are exceeded, device functional operation is not implied, damage may occur and reliability may be affected.

1. 10 seconds max.
2. 60 seconds max above 183°C

\*The maximum package power dissipation must be observed.

# CS8361

**ELECTRICAL CHARACTERISTICS** ( $6.0\text{ V} \leq V_{IN} \leq 26\text{ V}$ ,  $I_{OUT1} = I_{OUT2} = 100\ \mu\text{A}$ ,  $-40^\circ\text{C} \leq T_A \leq +125^\circ\text{C}$ ,  $-40^\circ\text{C} \leq T_J \leq +150^\circ\text{C}$ ; unless otherwise stated.)

Characteristic	Test Conditions	Min	Typ	Max	Unit
----------------	-----------------	-----	-----	-----	------

## Tracking Output ( $V_{TRK}$ )

$V_{TRK}$ Tracking Error ( $V_{STBY} - V_{TRK}$ )	$6.0\text{ V} \leq V_{IN} \leq 26\text{ V}$ , $100\ \mu\text{A} \leq I_{TRK} \leq 250\text{ mA}$ . Note 3	-25	-	+25	mV
Adjust Pin Current, $I_{Adj}$	Loop in Regulation	-	1.5	5.0	$\mu\text{A}$
Line Regulation	$6.0\text{ V} \leq V_{IN} \leq 26\text{ V}$ . Note 3	-	5.0	50	mV
Load Regulation	$100\ \mu\text{A} \leq I_{TRK} \leq 250\text{ mA}$ . Note 3	-	5.0	50	mV
Dropout Voltage ( $V_{IN} - V_{TRK}$ )	$I_{TRK} = 100\ \mu\text{A}$ . $I_{TRK} = 250\text{ mA}$	-	100	150	mV
		-	400	700	mV
Current Limit	$V_{IN} = 12\text{ V}$ , $V_{TRK} = 4.5\text{ V}$	275	500	-	mA
Quiescent Current	$V_{IN} = 12\text{ V}$ , $I_{TRK} = 250\text{ mA}$ , No Load on $V_{STBY}$	-	25	50	mA
Reverse Current	$V_{TRK} = 5.0\text{ V}$ , $V_{IN} = 0\text{ V}$	-	200	1500	$\mu\text{A}$
Ripple Rejection	$f = 120\text{ Hz}$ , $I_{TRK} = 250\text{ mA}$ , $7.0\text{ V} \leq V_{IN} \leq 17\text{ V}$	60	70	-	dB

## Standby Output ( $V_{STBY}$ )

Output Voltage, $V_{STBY}$	$6.0\text{ V} \leq V_{IN} \leq 26\text{ V}$ , $100\ \mu\text{A} \leq I_{STBY} \leq 100\text{ mA}$ .	4.9	5.0	5.1	V
Line Regulation	$6.0\text{ V} \leq V_{IN} \leq 26\text{ V}$ .	-	5.0	50	mV
Load Regulation	$100\ \mu\text{A} \leq I_{STBY} \leq 100\text{ mA}$ .	-	5.0	50	mV
Dropout Voltage ( $V_{IN} - V_{STBY}$ )	$I_{STBY} = 100\ \mu\text{A}$ . $I_{STBY} = 100\text{ mA}$	-	100	150	mV
		-	400	600	mV
Current Limit	$V_{IN} = 12\text{ V}$ , $V_{STBY} = 4.5\text{ V}$	125	200	-	mA
Short Circuit Current	$V_{IN} = 12\text{ V}$ , $V_{STBY} = 0\text{ V}$	10	100	-	mA
Quiescent Current	$V_{IN} = 12\text{ V}$ , $I_{STBY} = 100\text{ mA}$ , $I_{TRK} = 0\text{ mA}$ $V_{IN} = 12\text{ V}$ , $I_{STBY} = 300\ \mu\text{A}$ , $I_{TRK} = 0\text{ mA}$	-	10	20	mA
		-	140	200	$\mu\text{A}$
Reverse Current	$V_{STBY} = 5.0\text{ V}$ , $V_{IN} = 0\text{ V}$	-	100	200	$\mu\text{A}$
Ripple Rejection	$f = 120\text{ Hz}$ , $I_{STBY} = 100\text{ mA}$ , $7.0\text{ V} \leq V_{IN} \leq 17\text{ V}$	60	70	-	dB

## RESET ENABLE Functions

ENABLE Input Threshold	-	0.8	1.2	2.0	V
ENABLE Input Bias Current	$V_{ENABLE} = 0\text{ V}$ to $10\text{ V}$	-10	0	10	$\mu\text{A}$
RESET Threshold High ( $V_{RH}$ )	$V_{STBY}$ Increasing	4.59	4.87	$V_{STBY} - 0.02$	V
RESET Hysteresis	-	60	120	180	mV
RESET Threshold Low ( $V_{RL}$ )	$V_{STBY}$ Decreasing	4.53	4.75	$V_{STBY} - 0.08$	V
RESET Leakage	-	-	-	25	$\mu\text{A}$
Output Voltage, Low ( $V_{RLO}$ )	$1.0\text{ V} \leq V_{STBY} \leq V_{RL}$ , $R_{RST} = 10\text{ k}\Omega$	-	0.1	0.4	V
Output Voltage, Low ( $V_{RPEAK}$ )	$V_{STBY}$ ; Power Up, Power Down	-	0.6	1.0	V

## Protection Circuitry (Both Outputs)

Independent Thermal Shutdown	$V_{STBY}$ $V_{TRK}$	150	180	-	$^\circ\text{C}$
		150	165	-	$^\circ\text{C}$
Overvoltage Shutdown	-	30	34	38	V

3.  $V_{TRK}$  connected to Adj lead.  $V_{TRK}$  can be set to higher values by using an external resistor divider.

PACKAGE PIN DESCRIPTION

PACKAGE PIN #		PIN SYMBOL	FUNCTION
D <sup>2</sup> PAK, 7 Pin	SO-16L		
1	16	V <sub>STBY</sub>	Standby output voltage delivering 100 mA.
2	1	V <sub>IN</sub>	Input voltage.
3	3	V <sub>TRK</sub>	Tracking output voltage controlled by ENABLE delivering 250 mA.
4	4, 5, 12, 13	GND	Reference ground connection.
5	6	Adj	Resistor divider from V <sub>TRK</sub> to Adj. Sets the output voltage on V <sub>TRK</sub> . If tied to V <sub>TRK</sub> , V <sub>TRK</sub> will track V <sub>STBY</sub> .
6	8	ENABLE	Provides on/off control of the tracking output, active LOW.
7	9	RESET	CMOS compatible output lead that goes low whenever V <sub>STBY</sub> falls out of regulation.
	2, 7, 10, 11, 14, 15	NC	No connection.

CIRCUIT DESCRIPTION

**ENABLE Function**

The ENABLE function switches the output transistor for V<sub>TRK</sub> on and off. When the ENABLE lead voltage exceeds 1.4 V (Typ), V<sub>TRK</sub> turns off. This input has several hundred millivolts of hysteresis to prevent spurious output activity during power-up or power-down.

**RESET Function**

The RESET is an open collector NPN transistor, controlled by a low voltage detection circuit sensing the V<sub>STBY</sub> (5.0 V) output voltage. This circuit guarantees the RESET output stays below 1.0 V (0.1 V Typ) when V<sub>STBY</sub> is as low as 1.0 V to ensure reliable operation of microprocessor-based systems.

**V<sub>TRK</sub> Output Voltage**

This output uses the same type of output device as V<sub>STBY</sub>, but is rated for 250 mA. The output is configured as a tracking regulator of the standby output. By using the standby output as a voltage reference, giving the user an external programming lead (Adj lead), output voltages from 5.0 V to 20 V are easily realized. The programming is done with a simple resistor divider (Figure 2), and following the formula:

$$V_{TRK} = V_{STBY} \times (1 + R1/R2) + I_{Adj} \times R1$$

If another 5.0 V output is needed, simply connect the Adj lead to the V<sub>TRK</sub> output lead.

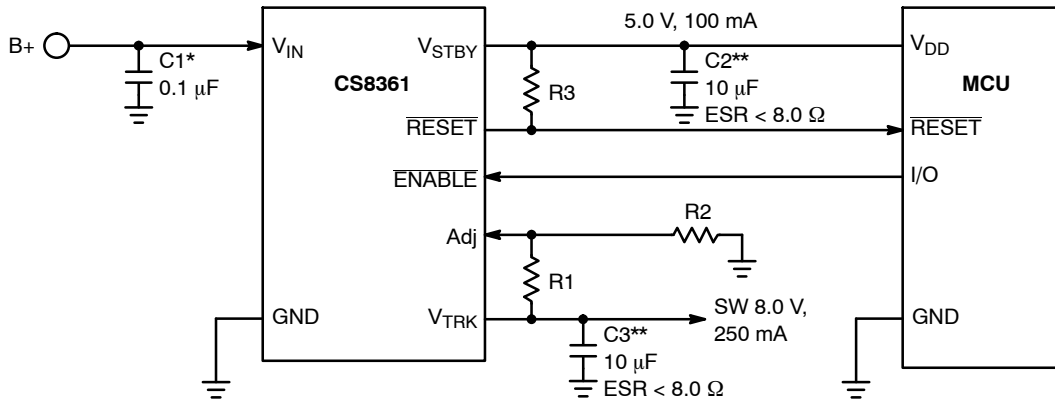

$V_{TRK} \sim V_{STBY}(1 + R1/R2)$   
 For  $V_{TRK} \sim 8.0$  V,  $R1/R2 \sim 0.6$

\*C1 is required if regulator is located far from power supply filter.  
 \*\*C2 and C3 are required for stability.

Figure 2. Test and Application Circuit, 5.0 V, 8.0 V Regulator

# CS8361

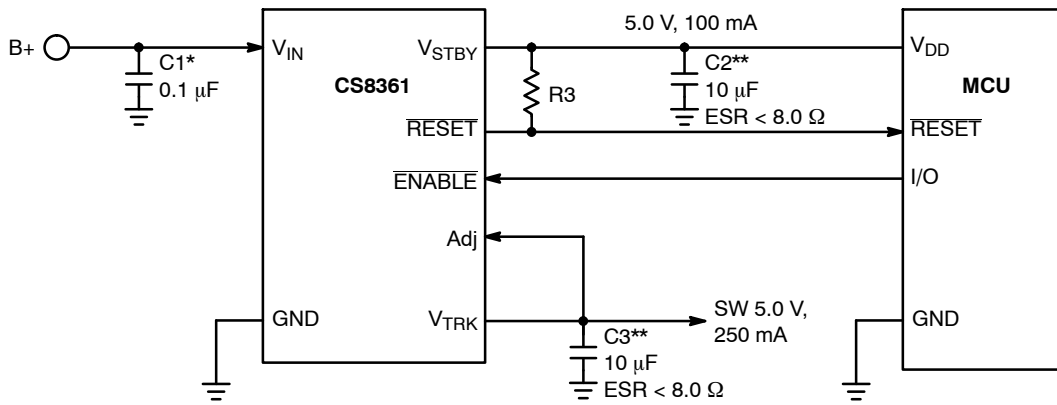

\*C1 is required if regulator is located far from power supply filter.

\*\*C2 and C3 are required for stability.

**Figure 3. Test and Application Circuit, Dual 5.0 V Regulator**

## APPLICATION NOTES

### External Capacitors

Output capacitors for the CS8361 are required for stability. Without them, the regulator outputs will oscillate. Actual size and type may vary depending upon the application load and temperature range. Capacitor effective series resistance (ESR) is also a factor in the IC stability. Worst-case is determined at the minimum ambient temperature and maximum load expected.

Output capacitors can be increased in size to any desired value above the minimum. One possible purpose of this would be to maintain the output voltages during brief conditions of negative input transients that might be characteristic of a particular system.

Capacitors must also be rated at all ambient temperatures expected in the system. To maintain regulator stability down to  $-40^{\circ}\text{C}$ , capacitors rated at that temperature must be used.

More information on capacitor selection for SMART REGULATOR®s is available in the SMART REGULATOR application note, "Compensation for Linear Regulators," document number SR003AN/D, available through the Literature Distribution Center or via our website at <http://www.onsemi.com>.

### Calculating Power Dissipation in a Dual Output Linear Regulator

The maximum power dissipation for a dual output regulator (Figure 4) is

$$PD(\max) = (V_{IN(\max)} - V_{OUT1(\min)})I_{OUT1(\max)} + (V_{IN(\max)} - V_{OUT2(\min)})I_{OUT2(\max)} + V_{IN(\max)}I_Q \quad (1)$$

where:

$V_{IN(\max)}$  is the maximum input voltage,

$V_{OUT1(\min)}$  is the minimum output voltage from  $V_{OUT1}$ ,

$V_{OUT2(\min)}$  is the minimum output voltage from  $V_{OUT2}$ ,

$I_{OUT1(\max)}$  is the maximum output current, for the application,

$I_{OUT2(\max)}$  is the maximum output current, for the application, and

$I_Q$  is the quiescent current the regulator consumes at both  $I_{OUT1(\max)}$  and  $I_{OUT2(\max)}$ .

Once the value of  $P_{D(\max)}$  is known, the maximum permissible value of  $R_{\theta JA}$  can be calculated:

$$R_{\theta JA} = \frac{150^{\circ}\text{C} - T_A}{P_D} \quad (2)$$

The value of  $R_{\theta JA}$  can be compared with those in the package section of the data sheet. Those packages with  $R_{\theta JA}$ 's less than the calculated value in equation 2 will keep the die temperature below  $150^{\circ}\text{C}$ .

In some cases, none of the packages will be sufficient to dissipate the heat generated by the IC, and an external heatsink will be required.

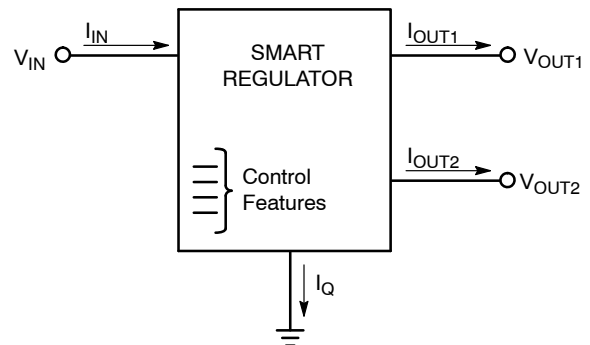

**Figure 4. Dual Output Regulator With Key Performance Parameters Labeled.**

# CS8361

## Heat Sinks

A heat sink effectively increases the surface area of the package to improve the flow of heat away from the IC and into the surrounding air.

Each material in the heat flow path between the IC and the outside environment will have a thermal resistance. Like series electrical resistances, these resistances are summed to determine the value of  $R_{\theta JA}$ :

$$R_{\theta JA} = R_{\theta JC} + R_{\theta CS} + R_{\theta SA} \quad (3)$$

where:

$R_{\theta JC}$  = the junction-to-case thermal resistance,  
 $R_{\theta CS}$  = the case-to-heatsink thermal resistance, and  
 $R_{\theta SA}$  = the heatsink-to-ambient thermal resistance.

$R_{\theta JC}$  appears in the package section of the data sheet. Like  $R_{\theta JA}$ , it too is a function of package type.  $R_{\theta CS}$  and  $R_{\theta SA}$  are functions of the package type, heatsink and the interface between them. These values appear in heat sink data sheets of heat sink manufacturers.

## ORDERING INFORMATION\*

Device	Package	Shipping†
CS8361YDPS7G	D <sup>2</sup> PAK-7 (Pb-Free)	50 Units/Rail
CS8361YDPSR7G	D <sup>2</sup> PAK-7 (Pb-Free)	750 / Tape & Reel
CS8361YDWF16G	SO-16L (Pb-Free)	46 Units/Rail
CS8361YDWFR16G	SO-16L (Pb-Free)	1000 / Tape & Reel

†For information on tape and reel specifications, including part orientation and tape sizes, please refer to our Tape and Reel Packaging Specifications Brochure, BRD8011/D.

\*Contact your local sales representative for other package options including PSOP-20, TO-220-7, DIP-16, and SO-20L.

# MECHANICAL CASE OUTLINE PACKAGE DIMENSIONS

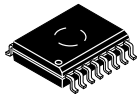

1  
SCALE 1:1

SOIC-16 WB  
CASE 751G  
ISSUE E

DATE 08 OCT 2021

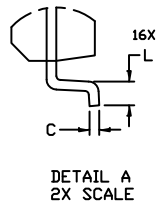
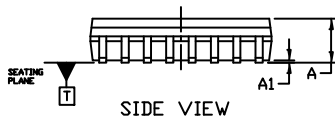
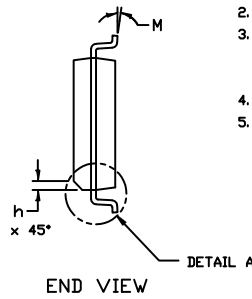
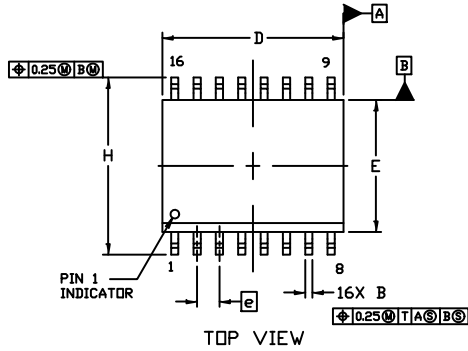

NOTES:

- DIMENSIONING AND TOLERANCING PER ASME Y14.5M, 1994.
- CONTROLLING DIMENSION: MILLIMETERS
- DIMENSION b DOES NOT INCLUDE DAMBAR PROTRUSION. ALLOWABLE PROTRUSION SHALL BE 0.13 TOTAL IN EXCESS OF B DIMENSION AT MAXIMUM MATERIAL CONDITION.
- DIMENSIONS D AND E DO NOT INCLUDE MOLD PROTRUSIONS.
- MAXIMUM MOLD PROTRUSION OR FLASH TO BE 0.15 PER SIDE.

DIM	MILLIMETERS	
	MIN.	MAX.
A	2.35	2.65
A1	0.10	0.25
B	0.35	0.49
C	0.23	0.32
D	10.15	10.45
E	7.40	7.60
e	1.27 BSC	
H	10.05	10.55
h	0.53 REF	
L	0.50	0.90
M	0°	7°

GENERIC MARKING DIAGRAM\*

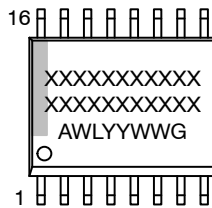

- XXXXX = Specific Device Code
- A = Assembly Location
- WL = Wafer Lot
- YY = Year
- WW = Work Week
- G = Pb-Free Package

\*This information is generic. Please refer to device data sheet for actual part marking. Pb-Free indicator, "G" or microdot "▪", may or may not be present. Some products may not follow the Generic Marking.

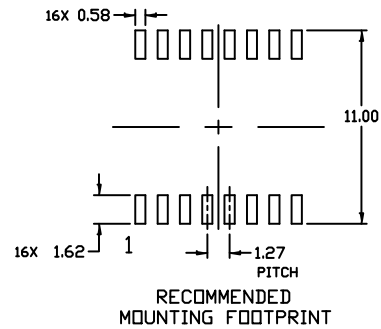

DOCUMENT NUMBER:	98ASB42567B	Electronic versions are uncontrolled except when accessed directly from the Document Repository. Printed versions are uncontrolled except when stamped "CONTROLLED COPY" in red.
DESCRIPTION:	SOIC-16 WB	PAGE 1 OF 1

onsemi and ONSEMI are trademarks of Semiconductor Components Industries, LLC dba onsemi or its subsidiaries in the United States and/or other countries. onsemi reserves the right to make changes without further notice to any products herein. onsemi makes no warranty, representation or guarantee regarding the suitability of its products for any particular purpose, nor does onsemi assume any liability arising out of the application or use of any product or circuit, and specifically disclaims any and all liability, including without limitation special, consequential or incidental damages. onsemi does not convey any license under its patent rights nor the rights of others.

# MECHANICAL CASE OUTLINE

## PACKAGE DIMENSIONS

ON Semiconductor®

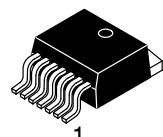

### D<sup>2</sup>PAK-7 (SHORT LEAD) CASE 936AB-01 ISSUE B

DATE 08 SEP 2009

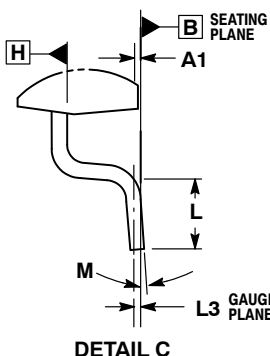
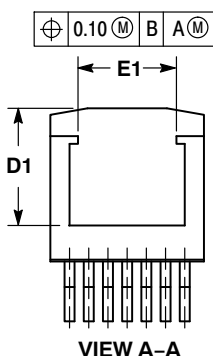
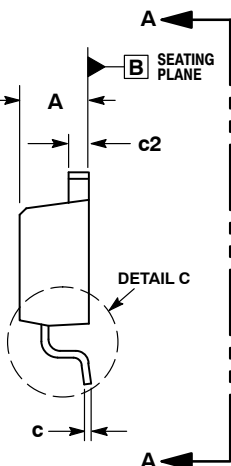
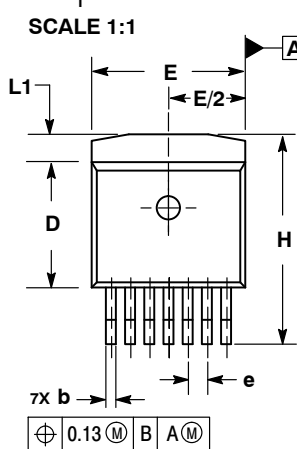

NOTES:

1. DIMENSIONING AND TOLERANCING PER ASME Y14.5M, 1994.
2. CONTROLLING DIMENSION: INCHES.
3. DIMENSIONS D AND E DO NOT INCLUDE MOLD FLASH AND GATE PROTRUSIONS. MOLD FLASH AND GATE PROTRUSIONS NOT TO EXCEED 0.005 MAXIMUM PER SIDE. THESE DIMENSIONS TO BE MEASURED AT DATUM H.
4. THERMAL PAD CONTOUR OPTIONAL WITHIN DIMENSIONS E, L1, D1, AND E1. DIMENSIONS D1 AND E1 ESTABLISH A MINIMUM MOUNTING SURFACE FOR THE THERMAL PAD.

DIM	INCHES		MILLIMETERS	
	MIN	MAX	MIN	MAX
A	0.170	0.180	4.32	4.57
A1	0.000	0.010	0.00	0.25
b	0.026	0.036	0.66	0.91
c	0.017	0.026	0.43	0.66
c2	0.045	0.055	1.14	1.40
D	0.325	0.368	8.25	9.53
D1	0.270	---	6.86	---
E	0.380	0.420	9.65	10.67
E1	0.245	---	6.22	---
e	0.050 BSC		1.27 BSC	
H	0.539	0.579	13.69	14.71
L	0.058	0.078	1.47	1.98
L1	---	0.066	---	1.68
L3	0.010 BSC		0.25 BSC	
M	0°		8°	

#### RECOMMENDED SOLDERING FOOTPRINT\*

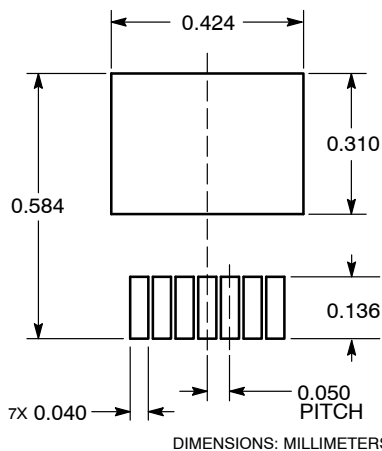

#### GENERIC MARKING DIAGRAM\*

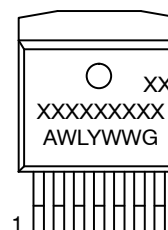

- XXXXXX = Specific Device Code
- A = Assembly Location
- WL = Wafer Lot
- Y = Year
- WW = Work Week
- G = Pb-Free Package

\*This information is generic. Please refer to device data sheet for actual part marking. Pb-Free indicator, "G" or microdot "▪", may or may not be present.

\*For additional information on our Pb-Free strategy and soldering details, please download the ON Semiconductor Soldering and Mounting Techniques Reference Manual, SOLDERRM/D.

DOCUMENT NUMBER:	98AON14119D	Electronic versions are uncontrolled except when accessed directly from the Document Repository. Printed versions are uncontrolled except when stamped "CONTROLLED COPY" in red.
DESCRIPTION:	D <sup>2</sup> PAK-7 (SHORT LEAD)	PAGE 1 OF 1

ON Semiconductor and are trademarks of Semiconductor Components Industries, LLC dba ON Semiconductor or its subsidiaries in the United States and/or other countries. ON Semiconductor reserves the right to make changes without further notice to any products herein. ON Semiconductor makes no warranty, representation or guarantee regarding the suitability of its products for any particular purpose, nor does ON Semiconductor assume any liability arising out of the application or use of any product or circuit, and specifically disclaims any and all liability, including without limitation special, consequential or incidental damages. ON Semiconductor does not convey any license under its patent rights nor the rights of others.



**onsemi**, **Onsemi**, and other names, marks, and brands are registered and/or common law trademarks of Semiconductor Components Industries, LLC dba "**onsemi**" or its affiliates and/or subsidiaries in the United States and/or other countries. **onsemi** owns the rights to a number of patents, trademarks, copyrights, trade secrets, and other intellectual property. A listing of **onsemi**'s product/patent coverage may be accessed at [www.onsemi.com/site/pdf/Patent-Marking.pdf](http://www.onsemi.com/site/pdf/Patent-Marking.pdf). **onsemi** reserves the right to make changes at any time to any products or information herein, without notice. The information herein is provided "as-is" and **onsemi** makes no warranty, representation or guarantee regarding the accuracy of the information, product features, availability, functionality, or suitability of its products for any particular purpose, nor does **onsemi** assume any liability arising out of the application or use of any product or circuit, and specifically disclaims any and all liability, including without limitation special, consequential or incidental damages. Buyer is responsible for its products and applications using **onsemi** products, including compliance with all laws, regulations and safety requirements or standards, regardless of any support or applications information provided by **onsemi**. "Typical" parameters which may be provided in **onsemi** data sheets and/or specifications can and do vary in different applications and actual performance may vary over time. All operating parameters, including "Typicals" must be validated for each customer application by customer's technical experts. **onsemi** does not convey any license under any of its intellectual property rights nor the rights of others. **onsemi** products are not designed, intended, or authorized for use as a critical component in life support systems or any FDA Class 3 medical devices or medical devices with a same or similar classification in a foreign jurisdiction or any devices intended for implantation in the human body. Should Buyer purchase or use **onsemi** products for any such unintended or unauthorized application, Buyer shall indemnify and hold **onsemi** and its officers, employees, subsidiaries, affiliates, and distributors harmless against all claims, costs, damages, and expenses, and reasonable attorney fees arising out of, directly or indirectly, any claim of personal injury or death associated with such unintended or unauthorized use, even if such claim alleges that **onsemi** was negligent regarding the design or manufacture of the part. **onsemi** is an Equal Opportunity/Affirmative Action Employer. This literature is subject to all applicable copyright laws and is not for resale in any manner.

## ADDITIONAL INFORMATION

### TECHNICAL PUBLICATIONS:

Technical Library: [www.onsemi.com/design/resources/technical-documentation](http://www.onsemi.com/design/resources/technical-documentation)  
onsemi Website: [www.onsemi.com](http://www.onsemi.com)

### ONLINE SUPPORT: [www.onsemi.com/support](http://www.onsemi.com/support)

For additional information, please contact your local Sales Representative at [www.onsemi.com/support/sales](http://www.onsemi.com/support/sales)